



THE HIGHWAYS AGENCY

BA 19/85



THE SCOTTISH OFFICE DEVELOPMENT DEPARTMENT



THE WELSH OFFICE
Y SWYDDFA GYMREIG



THE DEPARTMENT OF THE ENVIRONMENT
FOR NORTHERN IRELAND

The Use of BS 5400: Part 3: 1982

Summary: This Departmental Advice Note gives guidance on the use of BS 5400: Part 3 for the design of highway bridges in steel.

VOLUME 1	HIGHWAY STRUCTURES: APPROVAL PROCEDURES AND GENERAL DESIGN
SECTION 3	GENERAL DESIGN

BA 19/85

THE USE OF BS 5400: PART 3: 1982

Contents

Chapter

1. Scope
2. General
3. Analysis of Structure
4. General Guidance
5. References
6. Enquiries

Appendix A Design Example for a 20mm Span
Simply Supported Composite Bridge
Deck

1. SCOPE

The Advice Note gives advice on and clarification of certain aspects of clauses in BS 5400: Part 3. It should be read in conjunction with Departmental Standard BD 13/82. A design example of a 20m span simply supported composite highway bridge is included in an Appendix and illustrates in detail the use of the relevant clauses in Part 3. A more general treatment of the complete design of such a bridge to BS 5400 is given in the design guide published by CONSTRADO.

SUPERSEDED

2. GENERAL

BS 5400: Part 3 has been drafted to cover the design of most elements found in steel bridges. It is known, however, that a number of aspects are not covered, eg truss type support diaphragms and intermediate plated diaphragms for box girders, steel castings, steel cables etc. Where it is necessary to use these, or any other form of element that is clearly outside the scope of BS 5400: Part 3, the designers should discuss their use with the Technical Approval Authority in accordance with the Departmental Standard BD 2/79. The clauses referred to in this Advice Note are those in BS 5400: Part 3.

SUPERSEDED

3. ANALYSIS OF STRUCTURE

3.1 Stress Analysis

In continuous beams, or in beams where the cross section changes, it is possible to get a critical section which is compact and another which is non-compact. For checking any section, design clauses appropriate to the particular section under consideration should be used. The design clauses for non-compact sections will however always give a conservative result when applied to a compact section.

It should be noted that in staged construction a beam may be compact in the final structure but non-compact at an earlier stage. In checking the member for different stages of construction, the design clauses appropriate to the stage being considered, should be used.

SUPERSEDED

4. GENERAL GUIDANCE

4.1 Values of Partial Safety Factors, Clause 4.3.3

When considering the weight of formwork in the various stages of construction of a composite bridge the value of the partial safety factor γ_{fl} given in clause 5.9.1.2 of BS 5400: Part 2 shall be used both for application and removal effects. At the serviceability limit state the partial safety factor should be taken as 1.0. For bending resistance of non compact sections, the permanent stresses in the steel member due to formwork should be included in all load combinations.

4.2 Slenderness, Clause 9.7

4.2.1 When applying figure 9 to obtain " η " it is possible to obtain a value of ' M_A/M_M ' greater than + 1.0, eg where intermediate restraints are provided on a simply supported beam. Where ' M_A/M_M ' is greater than + 1.0 the value of " η " should be taken as 1.0.

4.2.2 In note 2 of clause 9.7.2, rules are given for determining the equivalent thickness of a concrete flange. In determining " t_f " as defined in clause 9.7.2 the thickness of a composite flange should be taken as the thickness of the steel plate plus the equivalent thickness of the concrete section as given in Note 2. The thickness of the tension flange in the negative moment region of the composite beam should be taken as the thickness of the steel plate plus the equivalent thickness of the tension reinforcement.

4.3 Transverse web stiffeners other than at support, Clause 9.13 Load bearing support stiffeners, Clause 9.14

The connections between the webs and the stiffeners should be designed for an assumed shear equal to 2.5% of the sum of the axial forces in the web stiffeners. The load effects to be considered in calculating the axial forces are given in clauses 9.13.3.1 and 9.14.3.1.

4.4 Load bearing support stiffeners, Clause 9.14

Notwithstanding the requirements of clause 3.1 of BD 13/82, the provision of symmetrical stiffeners, though desirable, is not mandatory.

4.5 Fasteners subjected to shear only, Clause 14.5.3.4

Clause 14.5.3.4 allows the use of the bolt shank area to be taken as the shear area. For bolts other than turned barrel bolts, this should only be adopted where it can be ensured that the threaded length is clear of the shear planes eg where the bolt dimensions are clearly shown on the drawings. Allowance should always be made for the tolerances on the threaded length.

For HSFG bolts in accordance with BS 4395: Parts 1 and 2, it is desirable to have a reasonable thread length within the grip length of the bolt, as the major proportion of bolt extension takes place in this length. When checked for their shear capacity, therefore, in accordance with 14.5.4.1.1 (b) the shear planes should always be assumed to pass through the threaded length.

4.6 Strength of HSFG bolts acting in friction, Clause 14.5.4

Design studies on the shear capacity of HSFG bolts acting in friction have shown that, for bolts in accordance with BS 4395: Part 1 for diameters M16 to M30 in normal clearance holes in plate plies exceeding 10mm, the friction capacity at the serviceability limit state will almost always be more critical than the bearing and shear capacity at the ultimate limit state. Beyond these ranges it will be necessary to check the bolt capacities at both limit states.

4.7 Slip factors, Clause 14.5.4.4

The value of $\mu = 0.5$, for blast cleaned surfaces should only be taken where the quality of finish is as specified in the Department's Specification for Road and Bridgeworks; ie 1st quality to BS 4232. The value of $\mu = 0.45$ should be adopted for other qualities of blast cleaned surfaces. Departmental Standard BD 7/81 specifies a 3rd quality blast cleaning to BS 4232 for weathering steel, and the lower value of μ should be used for this material.

SUPERSEDED

5. REFERENCES

The documents listed below are referred to in this Advice Note. Where reference is made to any part of BS 5400, this shall be taken as reference to that part as implemented by the Departmental Standard.

1. BS 5400 Steel, concrete and composite bridges.
Part 2 Specification for Loads
Part 3 Code of practice for the design of steel bridges
Part 4 Code of practice for the design of concrete bridges
Part 5 Code of practice for the design of composite bridges
Part 10 Code of practice for fatigue
2. Departmental Standard BD 14/82
Use of BS 5400: Part 2: 1978
3. Departmental Standard BD 13/82
Use of BS 5400: Part 3: 1982
4. Departmental Standard BD 17/83
Use of BS 5400: Part 4: 1978
5. Departmental Standard BD 16/82
Use of BS 5400: Part 5: 1979
6. Departmental Standard BD 9/81
Use of BS 5400: Part 10: 1980
7. Departmental Standard BD 2/79: Technical Approval of highway structures on Trunk Roads (including motorways)
8. Departmental Standard BD 7/81: Weathering steel for highway structures
9. BS 4395: Specification for high strength friction grip bolts Part 1: 1969 General Grade
10. Specification for Road and Bridge Works (1976 Edition) and Supplement No 1: 1978.. Published by HMSO
11. BS 4232: 1967 Surface Finish of Blast Cleaned Steel for Painting
12. Nash, G F J: Steel bridge design guide. Composite universal beam simply supported span, Constrado, January 1984

DESIGN EXAMPLE FOR A 20M SPAN SIMPLY SUPPORTED COMPOSITE BRIDGE DECK

A.1 INTRODUCTION

This Appendix to the Advice Note contains calculations illustrating the combined use of Parts 3 and 5 of BS 5400 for designing the structural steelwork of a 20m span two lane simply supported composite highway bridge.

The general arrangement of the bridge and its cross-section are shown in Figure 1. The dimensions indicated in Figure 1 were obtained from preliminary calculations that are not included in the Advice Note.

The general arrangement adopted for the design example is not necessarily the most economic solution or the one most favoured. It is adopted solely to illustrate the various clauses in the codes.

The deck consists of six universal beams acting compositely with an insitu concrete deck slab. Shear connection is achieved by means of stud shear connectors. The longitudinal beams are connected transversely by a reinforced concrete beam and there are no other transverse connections within the span. An expansion joint is provided at one of the supports.

A.2 SCOPE

The calculations given in this Appendix cover the design of:

- a. an internal girder;
- b. shear connectors;
- c. bearing stiffeners.

The design of the transverse reinforced concrete member at the support has not been covered but the loadings are given.

A.3 GLOBAL ANALYSIS

Load effects due to dead and superimposed dead loads have been obtained by statically apportioning the load acting over a width of slab equal to the spacing of the beams.

Load effects due to live load have been obtained by grillage analysis using section properties based on the gross dimensions.

A.4 LOADING

All loads and load combinations are in accordance with BS 5400: Part 2 as implemented by the Departmental Standard BD 14/82.

It is assumed that the effects of wind load (combination 2) secondary effects of live load (combination 4) and friction at bearings (combination 5) do not influence the design of the deck. In the example, uniform changes in temperature do not cause any stress since steel and concrete have the same coefficient of expansion and the supports allow movement in the longitudinal direction. Combination 3 therefore comprises dead load, live load and effects due to temperature differences.

Appendix A

A.5 DESIGN OF INTERNAL GIRDER

Unpropped construction is assumed and the entire slab cast in one pour so that there is no composite action under dead loads. The entire dead and live loads are carried by the compact composite section at both the serviceability and the ultimate limit states.

The effective section is determined and checked for compliance with the requirements at the ultimate limit state at each stage of construction, ie the initial steel section and the final composite section. The effects of shear lag are neglected for ultimate limit state. The torsional stresses are found to be small and they have not been considered in the design.
...Relevant Clause No. 9.4.2

Since the beam is compact both in the initial stage as well as the final stage of construction and restrained laterally in the final stage the effects due to creep, shrinkage and differential temperature and settlement of supports are also neglected.
...Relevant Clause No. 9.2.1.3

The composite section is additionally checked for compliance with the serviceability requirements by treating the beam as non-compact. For these calculations it is assumed that the settlement of supports is zero and the effects due to shear lag, creep, shrinkage and differential temperature only are considered. The effective section is determined on the basis of the shear lag factors taken from table 4 of Part 3. Torsional stresses being very small are neglected.
...Relevant Clause No. 9.9.8

A.6 DESIGN OF SHEAR CONNECTORS

The stud shear connectors are designed for serviceability loading and checked for compliance with the fatigue requirements of Part 10. As the whole loading is taken on compact section at the ultimate limit state, the shear connectors are additionally checked at the ultimate limit state.

The loads at the serviceability limit state include effects due to creep, shrinkage and temperature differences. The longitudinal shear due to these loads is ignored since their effects tend to diminish those produced by the superimposed dead and live loads.

A.7 DESIGN OF BEARING STIFFENERS

The bearing stiffeners are designed to satisfy the buckling and yielding requirements at the ultimate limit state.

A.8 TRANSVERSE MEMBER AT THE SUPPORT

The transverse member at the support is a reinforced concrete beam connecting the longitudinal beams. A simpler detail for erection would have been a steel cross beam connected to the bearing stiffeners, but studies of a particular design have shown that a full penetration butt weld is required for the web/stiffener connection to ensure adequate fatigue life.

The beam is designed for the ultimate limit state to resist the load effects due to 9.15.4.1(a). Some of the load effects given in 9.15.4.1 eg items (c), (e), (f), (g) do not apply in this case because of the geometry of the bridge cross-section; other effects eg items (b), (d) are considered to be small and therefore ignored. The transverse beam should be cast before the deck slab.

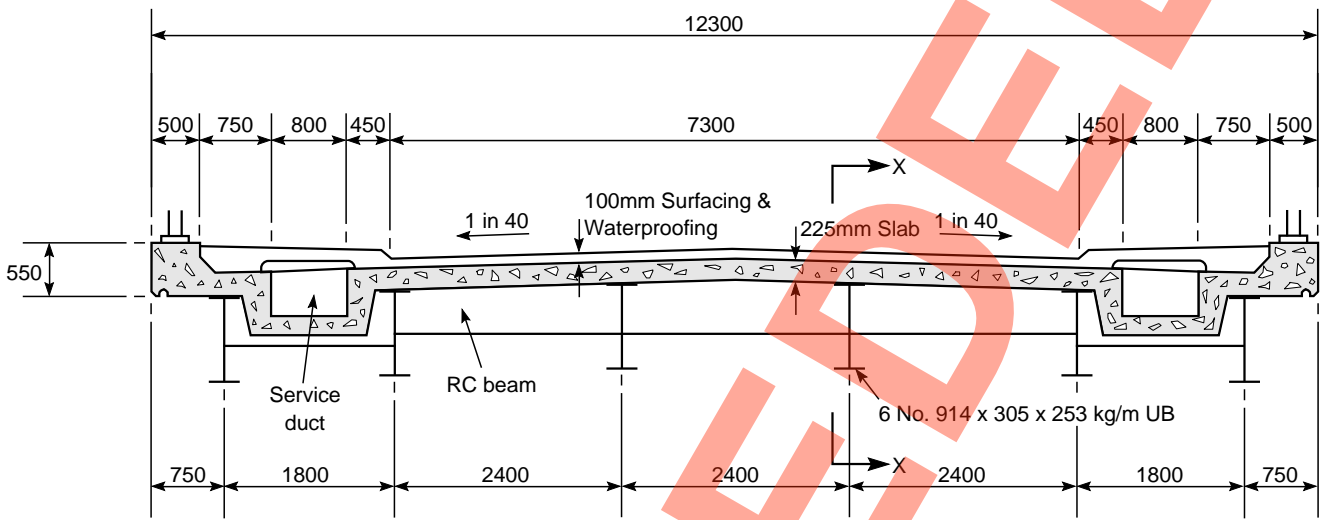

SECTION

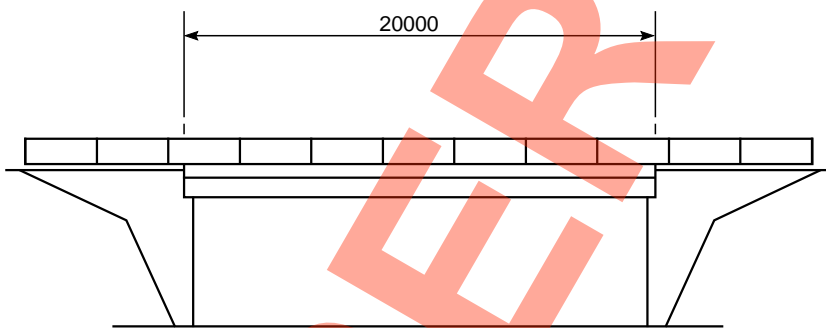

ELEVATION

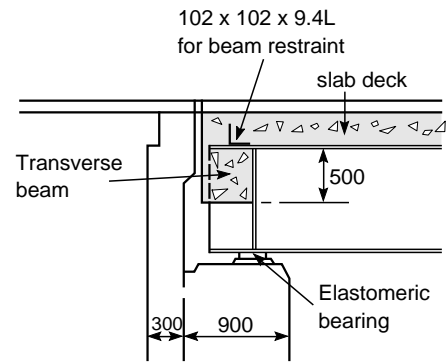

SECTION X-X AT ABUTMENT

FIGURE 1 DETAILS OF THE BRIDGE

Appendix A

A.9 DESIGN CALCULATIONS

Bridge Details (Figure 1)

Effective span	= 20800 mm
Spacing of universal beams	= 2400 mm
Carriageway width	= 7300 mm
Concrete deck thickness	= 225 mm
Surfacing thickness	= 100 mm

Materials

Item	Grade	Property	Value	Reference ⁽¹⁾
Steel	50 C ⁽³⁾	Yield stress Young's modulus	355 N/mm ² ⁽²⁾ 205 kN/mm ²	BS 4360 6.6
Concrete	30	Cube strength Young's modulus - short term - long term	30 N/mm ² 28 kN/mm ² 14 kN/mm ²	Table 3 Part 4 Table 2 Part 4 4.2.3 Part 5
Modular ratio		Short term Long term	7.32 14.64 ⁽⁴⁾	

Table A1 Summary of material properties

NOTE:

- (1) Unless expressly stated all references are to BS 5400: Part 3 as amended by the Departmental Standard BD 13/82.
- (2) The yield strength as per BS 4360 for universal beam with a flange plate thickness over 25 mm is 345 N/mm². But for the sake of convenience the value adopted in this example is 355 N/mm².
- (3) Grade 50 C steel has been selected on the basis of the notch ductility requirements of Part 3. The limiting maximum thickness specified in it is 40 mm for UB section for an assumed design minimum temperature of -20°C.
...Relevant information Table 3 (b)
- (4) The global analysis may be based on the long term value of the elastic modular ratio. But stress analysis should be done with the modular ratio appropriate to the stage of construction.
...Relevant Clause 6.7

A. DESIGN OF INTERNAL BEAM

Steel section - ultimate limit state

Effective section

A 914 × 305 × 253 kg/m UB is adopted on the basis of a preliminary analysis, having:

Overall depth	= 918.5 mm
Flange thickness	= 27.9 mm
Flange width	= 305.5 mm
Web thickness	= 17.3 mm

Check whether the section adopted is compact or not.

Compression web depth (y_c) = 431.4 mm = $24.9t_w < 28t_w$...Relevant Clause 9.3.7.2.1

Use actual web thickness since $y_c < 68t_w$... Relevant Clause 9.4.2.5.1 (a)

Flange outstand = 144.1mm = $5.2t_{fo} < 7t_{fo}$... Relevant Clause 9.3.7.3.1

Section is compact

Loading

The steel beam initially carries self-weight and the weight of the insitu concrete slab. Load effects summarised in Table A2 have been combined in accordance with factors specified in Part 2. No allowance is made for the weight of the formwork.

Bending Resistance (steel beam only)

Determine limiting compressive stress σ_c ...Relevant Clause 9.8.2

The beam has simple supports and is restrained against torsion and lateral displacement.

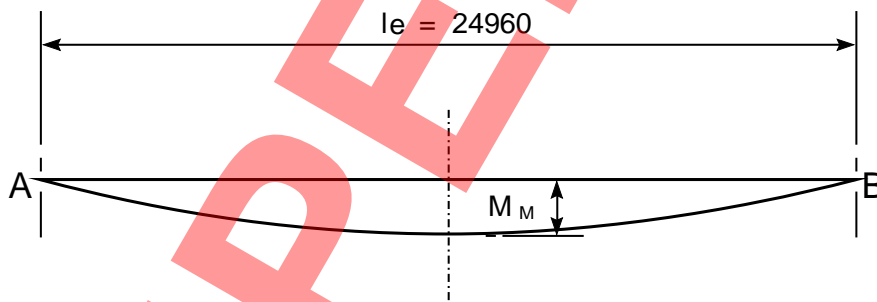

$l_e = (1.0)(1.2)(20800) = 24960$ mm ...Relevant Clause 9.6.3

$M_A = M_B = 0 ; M_A/M_M = 0$...Relevant information Figure 9b

$\eta = 0.941$

$\lambda F = (24960)(27.9)/(64.2)(918.5) = 11.81$...Relevant Clause 9.7.2

$v = 0.595$ for $i = 0.5$...Relevant information Table 9

Appendix A

$$\lambda_{LT} = (24960)(0.9)(0.941)(0.595)/64.2 = 195.9 \quad \dots\text{Clause 9.7.2}$$

$$\sigma_{li}/\sigma_{yc} = 0.13 \quad \dots\text{Figure 10}$$

$$\sigma_{li} = (0.13)(355) = 46.15 \text{ N/mm}^2$$

$$M_D = (10.90)(46.15)/(1.2)(1.1) = 383 \text{ kN m} \quad \dots\text{Clause 9.9.1.2}$$

$< 947.9 \text{ kN m applied}$

The beam is satisfactory for self weight without bracings. However, temporary restraint is required to ensure lateral stability when the beam carries the wet concrete. Therefore provide temporary restraint at midspan.

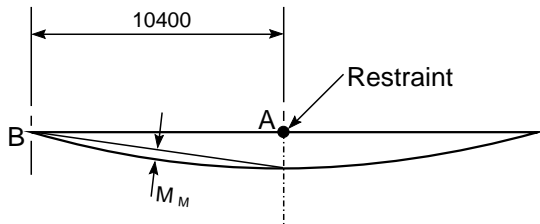

$$M_A = -947.9 \text{ kN m} \quad \dots\text{Clause 9.6.2}$$

$$M_B = 0$$

$$M_M = M_A/4$$

$M_A/M_M = 4.0$ - outside scope of Figure 9 and hence η is taken to equal 1.0

$$\lambda_F = (10400)(27.9)/(64.2)(918.5) = 4.92 \quad \dots\text{Clause 9.7.2}$$

$$v = 0.82 \text{ for } i = 0.5 \quad \dots\text{Table 9}$$

$$\lambda_{LT} = (10400)(0.9)(1.0)(0.82)/(64.2) = 119.6 \quad \dots\text{Clause 9.7.2}$$

$$\sigma_{li}/\sigma_{yc} = 0.325 \quad \dots\text{Figure 10}$$

$$\sigma_{li} = (0.325)(355) = 115.5 \text{ N/mm}^2$$

$$M_D = (383)(115.5)/46.15 = 958 \text{ kN m} \quad \dots\text{Clause 9.9.1.2}$$

$> 947.9 \text{ kN m applied}$

i.e., provision of a temporary restraint at midspan will ensure adequate lateral stability. Wind effects should be considered at the erection stage but are not included in this example.

Shear Resistance

$$\lambda = (862.7)(355/355)^{1/2}/17.3 = 49.87 \quad \dots\text{Clause 9.9.2.2}$$

$$\tau_y = 355/1.732 = 205 \text{ N/mm}^2$$

$$\phi = 20800/862.7 = 24.11$$

$$b_{fe} = 152.8$$

$$m_{fw} = (0.5)(355/355)(152.8)(27.9)^2/(862.7)^2(17.3) = .005$$

From Figure 12 $\tau_1/\tau_y = 1.0$

$$V_D = (17.3)(918.5)(205)/(1.05)(1.1) = 2820 \text{ kN}$$

> 182.3 kN applied

Section OK and no intermediate stiffeners are needed

Combined bending and shear

$$M_R = (115.5)(.3055)(27.9)(918.5 - 27.9)/(1.05)(1.1) \quad \dots\text{Clause 9.9.3.1}$$

$$= 877 \text{ kN m}$$

$$M > M_R, V_D = V_R$$

$$947.9/958 + (1 - 877/958)((2)(182.3)/(2820) - 1) = 0.92 < 1 \quad \dots\text{Clause 9.9.3.1 (c)}$$

\therefore Section is OK.

Composite section - ultimate limit state

Composite section is also compact if shear connector spacing is in accordance with 9.3.7.3.3. Shear lag effects are ignored and transformed width determined in accordance with 9.9.1.2. Section properties are summarised in Table A3.

Loading

The load effects of 9.2.1.2 are summarised in Table A2. Effects due to shrinkage and temperature need not be considered for compact composite sections. ...Clause 9.2.1.3

Bending Resistance

Assume concrete deck continuously restrains steel flange

$$l_e = 0; \sigma_{fi} = 355 \text{ N/mm}^2 \quad \dots\text{Clause 9.6.6.1}$$

$$M_D = (16.8)(355)/(1.05)(1.1) = 5176 \text{ kN m} \quad \dots\text{Clause 9.9.1.2}$$

> 4307 kN m applied

Shear Resistance

Based on m_{fw} for the smaller flange, shear resistance as for steel section ...Clause 9.9.2.2

$$V_D = 2820 \text{ kN} > 1150.1 \text{ kN applied}$$

Section is OK.

Appendix A

Combined bending and shear

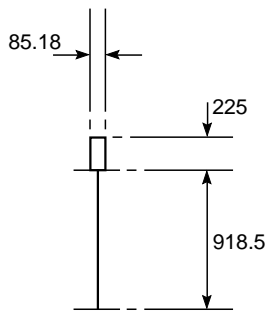

Transformed width = $(2400)(.4)(30)(1.05)/355 = 85.18 \text{ mm}$

...Clause 9.9.1.2

Determine centroid of flange

Concrete flange area = $(85.18)(225) = 19165 \text{ mm}^2$

Steel flange area = $(305.5)(27.9) = 8523 \text{ mm}^2$

Total flange area = 27688 mm^2

Centroid = $((19165)(112.5) + (8523)(238.9))/27688 = 151.4 \text{ mm}$
from top

$d_f = 918.5 + 225 - 151.4 - 13.95 = 978.1 \text{ mm}$

$M_R = (355)(305.5)(27.9)(978.1)/(1.05)(1.1) = 2562 \text{ kN m}$

...Clause 9.9.3.1

$M > M_R$

$4307/5176 + (1 - 2562/5176)((2)(1140)/(2820) - 1) = .735 < 1$

...Clause 9.9.3.1 (c)

Section OK no intermediate stiffeners needed.

Composite section - serviceability limit state

Effective section

The effective breadth at midspan is determined using shear lag factors corresponding to midspan section given in Table 4 of Part 3. Section properties for short term and long term loading and for determining temperature and shrinkage effects are summarised in Table A3.

Loading

Load effects of 9.2.3.2 are summarised in Table A2. Temperature and shrinkage effects are determined as specified in 5.4.2 to 5.4.3 of Part 5 ignoring shear lag effects. A sample calculation illustrating Table A4 is given below.

Positive temperature difference in Table A4
(Slice between levels 1 & 2)

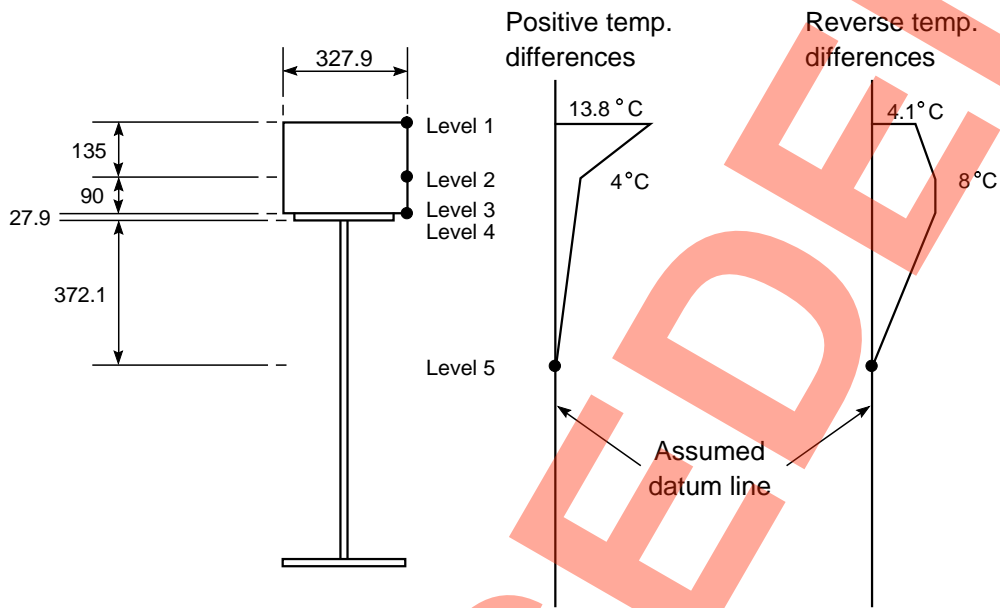

...Clause 9.9.7 for temperature and shrinkage effects is under consideration

$$\text{Average strain} = (165 + 48)/2 \times 10^{-6} = 106.5 \times 10^{-6}$$

$$\text{Force} = (106.5 \times 10^{-6})(205)(2400)(135)/7.32 = 966.3 \text{ kN}$$

$$\text{Lever arm} = 292.4 - 55.1 = 237.3 \text{ mm (Table A3)}$$

$$\text{Moment} = (966.3)(233.4)/(1000) = 229.3 \text{ kN m}$$

Appendix A

Loads	Unfactored values		Serviceability Combination 3			Ultimate Combination 1		
	Shear (kN)	Moment (kN m)	γ_{fl}	Shear (kN)	Moment (kN m)	γ_{fl}	Shear (kN)	Moment (kN m)
Dead slab - 225mm thick	134.8	700.9	1.00	134.8	700.9	1.15	155.0	806.0
914 x 305 x 253 UB beam	24.8	128.7	1.00	24.8	128.7	1.05	26.0	135.1
bracing	1.2	6.5	1.00	1.2	6.5	1.05	1.3	6.8
Total Dead					836.1		182.3	947.9
Superdead surfacing 100mm	59.9	311.5	1.20	71.9	373.8	1.75	104.8	545.1
Live load HA with HB	664.0	2164.0	1.00	664.0	2164.0	1.30	863.0	2814.0
Dead + Super + Live							1150.1	4307.0
Temperature +ve difference	Axial (kN) -1320.3	-260.8	0.80	Axial (kN) -1056.2	-208.6	-	-	-
-ve difference	-1461.3	-212.2	0.80	-1169	-169.8	-	-	-
Shrinkage	1512.0	413.8	1.00	1512.0	413.8	-	-	-

- Note: (1) Sagging moments and compressive axial forces positive;
(2) Signs of temperature and shrinkage loads, opposite that in Table A4;
(3) For temperature and shrinkage, the initial stresses due to restraint of deformation (Table A4) will have to be superimposed.
(4) Temperature forces act at the C.G of the composite section with short term modular ratio taken as 7.32.
(5) Shrinkage forces act at the C.G of the composite section with long term modular ratio taken as 14.64.

TABLE A2 SUMMARY OF LOADS AND LOAD EFFECTS AT MIDSPAN

Section	Transformed Width (mm)	\bar{y} (mm)	Inertia (mm ⁴)	Modulus (mm ³)	
Steel	-	459.3	-	7 1.09 x 10 ⁶ 9.51 x 10 ⁶	plastic elastic
Composite Ultimate	85.2	246.5	-	7 1.68 x 10 ⁶	...Clause 9.9.1.2
Serviceability - stresses short term	309.5	292.4	10 1.18 x 10 ⁹	7 1.38 x 10 ⁷	...Table 4
long term	154.8	386.2	9.90 x 10 ⁹	7 1.31 x 10 ⁷	... $\psi = 0.944$
- loads temperature (short term modular ratio)	309.5	292.4	10 1.18 x 10 ⁹	7 1.38 x 10 ⁷	
shrinkage (long term modular ratio)	154.8	386.2	9 9.90 x 10 ⁹	7 1.31 x 10 ⁷	

- NOTE: (1) Modulus for serviceability is with respect to bottom flange;
(2) \bar{y} is the centroidal distance from the top;
(3) Transformed width is in "steel" units.

Table A3 SUMMARY OF SECTION PROPERTIES

Effect	Level	Strain	Force (kN)	Line of action of force from top of slab	Lever arm (mm)	Moment (kNm)
Positive temperature difference						
top of slab - 13.75°C	1	-6 165 x 10	966.3	55.1	237.3	229.3
135mm from top - 4.00°	2	-6 48 x 10	263.7	178.5	113.9	30.0
top of steel flange - 3.27°	3	-6 39 x 10	66.2	238.8	53.6	3.5
bottom of flange - 3.04°	4	-7 365 x 10	24.1	376.9	84.5	-2.0
400mm below slab - 0.00°	5	0				
Shear at interface			1230.0			
Net restraining force on composite section			1320.3			260.8
Reverse temperature difference						
top of slab - 4.12°	1	-7 494 x 10				
135mm from top - 8.00°	2	-6 96 x 10	659.8	74.7	217.7	143.6
top of steel flange - 8.00°	3	-6 96 x 10	580.70	180	112.4	65.3
bottom of flange - 7.44°	4	-6 89 x 10	161.9	238.8	53.6	8.7
400mm below slab - 0.00°	5	0	58.9	376.9	84.5	-5.0
Shear at interface			1240.5			
Net restraining force on composite section			1461.3			212.6
Shrinkage	slab	-6 200 x 10	-1512.0	112.5	273.7	-413.8

- NOTE: (1) The strain is due to the restraining of deformation of the slab and the beam.
 (2) Forces specified are restraining forces required to prevent any movement of the slab and the beam.
 (3) The lever arm is measured from the C.G of the composite beam to the line of action of the restraining force.
 (4) The moment is applied at the C.G of the composite section.

TABLE A4 DETERMINATION OF LOAD EFFECTS DUE TO TEMPERATURE AND SHRINKAGE

Analysis for Serviceability Limit State

The stresses in the bottom flange are checked for loading specified in 9.2.3.2 treating the section as non compact. ...Clause 9.9.8

This is shown in Table A5. The allowable tensile stress is determined in accordance with 9.9.7. ...Clause 9.9.5.2

Appendix A

Loading	Force (kN or kNm)	Modulus (mm ³)	Stress (N/mm ²)	
Dead	836.1	9.51 x 10 ⁶	87.92	
Super Dead	373.8	1.31 x 10 ⁷	28.53	
Shrinkage - force	-1512.0	(6.82 x 10) ⁴	-22.17	
- moment	413.8	1.31 x 10 ⁷	31.59	
Differential temperature positive difference - axial force	1,056.2	(1.04 x 10) ⁵	10.16	ignored
- moment reverse difference	-208.64	1.38 x 10 ⁷	-15.12	ignored
- force	1169.0	(1.04 x 10) ⁵	11.24	ignored
- moment	169.8	1.38 x 10 ¹⁷	-12.30	ignored
Live (Combination 1)	2619.1	1.38 x 10 ⁷	191.20	
Live (Combination 3)	2381.0	1.38 x 10 ⁷	173.80	
Total (Combination 1)			316.07	< 345.92 N/mm ²
Total (Combination 3)			299.67	< 345.89 N/mm ²

NOTE: (1) Forces and moduli are from Tables A2 - A3;
 (2) Values in brackets under "Modulus" are areas;
 (3) Sagging moment and tensile stress positive.

TABLE A5 SERVICEABILITY STRESSES IN BOTTOM FLANGE

Calculations for Fatigue for the main beam

The fatigue assessment is carried out without damage calculation in accordance with clause 8.2 of BS 5400: Part 10 as the following conditions apply: ...Clause 8.2 of Part 10

- a) the detail class is in accordance with table 17
- b) the design life is 120 years
- c) the fatigue loading is the standard load spectrum
- d) the annual flows of commercial vehicles are as in table 1.

Midspan section

The detail assumed for the parent metal in the bottom flange (non-welded) is class B. ...Table 8 of Part 10
 Since the detail assumed is near the midspan the effect of any impact at the support is minimal and has been ignored.
 The load effects due to the standard fatigue vehicle are: ...Clause 7.2.4 of Part 10

Design moment = 328.8 kN m
Design shear = 18.4 kN

$$I(\text{composite}) = 1.18 \times 10^{10} \text{mm}^4$$

Centroidal distance from the top = 292.4 mm

$$\sigma_{\text{max}} = (328.8)(851.1)/(1.18)(10000) = 23.7 \text{ N/mm}^2$$

$$\tau = (18.4)/(1.5890) = 1.16 \text{ N/mm}^2$$

Since the shear stress is less than 15% of the direct stress this can be ignored. ...Clause 6.2.2 of Part 10

$$\sigma_{\text{pmax}} = 23.7 \text{ N/mm}^2; \sigma_{\text{pmin}} = 0$$

$$\sigma_{\text{vmax}} = 23.7 \text{ N/mm}^2;$$

From the figure 8(d), the limiting stress range is 73 N/mm².

Since $\sigma_H \gg \sigma_{\text{vmax}}$, the fatigue life is more than adequate.

B. DESIGN OF SHEAR CONNECTORS

Loading

Shear connectors are designed to resist serviceability loads. As the whole loading is taken on the compact section at the ultimate limit state, they are also checked for the ultimate limit state. ...Clause 5.3.3.5 Part 5

Longitudinal Shear

Longitudinal shears are determined in accordance with 5.3.1 and 5.4.2.3 of Part 5. Calculation of longitudinal shears is shown in Tables A6 and A7. Where the effects due to temperature and shrinkage are opposite to that produced due to vertical loads they are ignored in the design of shear connectors. A summary of the design shears is contained in Table A8.

Effect	Axial Stress (N/mm ²)	Bending Stress (N/mm ²)	Total Stress (N/mm ²)	Force (kN)	Net Force (kN)
Shrinkage Restraining	22.17	11.44	33.61	1171 -1512	-341
Temperature					
+ve differ	(1) -12.95 (2) -12.95	-4.97 -2.48	-17.92 -15.43	-749 -430	
Restraining				1230	51
-ve differ	(1) -14.34 (2) -14.34	-4.05 -2.03	-18.39 -16.37	-768 -456	
Restraining				1240.5	16.5

ignored

* Slice between levels in Table A4

NOTE: (1) Compressive stresses/forces positive;
(2) Bending stress determined at centroid of each slice using appropriate values in Table A2-A3;

Appendix A

(3) Force = stress × transformed concrete area.

SAMPLE CALCULATION (bending stress - temp slice 2)

$$\text{Stress} = (260.8)(112.4)/1.18 \times 10^4 = 2.48 \text{ N/mm}^2$$

$$\text{Force} = (15.13)(309.5)(90)/1000 = 430 \text{ kN}$$

Table A6 Longitudinal shears due to shrinkage and temperature

Effect	Shear (kN)	y (mm)	I (mm)	q (kN/m)
Dead load:			9	
Steel)	26	273.7	9.90 x 10	14.7
)			9	
Concrete)	134.8	273.7	9.90 x 10	76.5
)			9	
Super dead	59.9	273.7	9.90 x 10	57.7
)			10	
Live load	664.0	179.9	1.18 x 10	705.0

Table A7 Calculation of longitudinal shears due to dead, super dead and live load (unfactored)

Loading	q	Serviceability Combination 1 & 3		Ultimate Combination 1	
	(kN/m)	γ_f	q (kN/m)	γ_f	q (kN/m)
Dead load:					
Steel)	14.7			1.05	15.4
)					
Concrete)	76.5			1.15	88
)					
Super dead	57.7	1.20	69.2	1.75	101
Live load					
Combination 1	705.0	1.10	775.5	1.30	916.5
Combination 3	705.0	1.00	705.5		
Temperature	12.26	0.80	9.81	-	-
Total - Comb 1			844.7		1,120.9
Total - Comb 3			784.41		

* For stud connectors, $1 = (51)(5)/20.8 = 12.26 \text{ kN/m}$ (5.4.2.3 Pt 5)

Table A8 Summary of longitudinal shears

Design for serviceability limit state

Design Shear = 844.7 kN/m

Provide shear studs 22 × 100 mm - 3 in a line @ 225 c/c

Static Strength = 126 kN/stud

...Table 7 Part 5

Nominal static strength = $3(126)(1000)/225 = 1680 \text{ kN/m}$

Design strength = $1680/1.85 = 908 \text{ kN/m} > 844.7 \text{ kN/m}$

...Clause 5.3.2.5 Part 5

Spacing of 225 mm c/c less than

- a) $12t_f = 327.6$ mm ...Clause 9.3.7.3.3
- b) 600 mm ...Clause 5.3.3.1 of Part 5
- c) $3 \times$ slab thickness = 675 mm
- d) $4 \times$ stud height = 400 mm

Adopt maximum permitted spacing of 325 mm at midspan
Nominal strength = $(1680)(225)/325 = 1163$ kN/m

Stud shear connector OK.

Check at ultimate limit state

Since the entire load is taken by the final cross section, ...Clause 9.9.5.1
it is necessary to check the static strength of the shear connectors at the ultimate limit state. ...Clause 6.1.3 Part 5

Design Shear = 1120.9 kN/m
Capacity = $1680/1.40 = 1200$ kN/m > 1120.9 kN/m ...Clause 6.3.4 Part 5
Stud connector satisfies ultimate criteria

Check for fatigue

For shear connectors the design stresses for fatigue in the weld metal attaching shear connectors is calculated in accordance with the clause 6.4.2 of Part 10.

Fatigue loading

The stress range in the weld is determined on the basis of the standard fatigue vehicle. Maximum unfactored shears obtained are as follows: ...Clause 7.2.2.2 Part 10

Mid span = 44.5 kN
Support = 119.3 kN

As there is an expansion joint at the support, shears obtained above include impact allowance of 25% and 16% for the two axles within 5 m of the support. ...Clause 7.2.4 Part 10

Fatigue Assessment

The rigorous procedure of 8.4 in Part 10 cannot be used since damage charts exclude class S details. The simplified procedure of 8.2 is therefore used. Details of calculations are summarised in Table A9. Longitudinal shears are obtained as for live load shown in Table A7 using section properties corresponding to short term loading given in Table A3.

Location	q (kN/m)	Weld Stress		Stress Range (N/mm ²)	
		Max (N/mm ²)	Min (N/mm ²)		
Mid-span	47.2	17.2	-17.2	34.4	< 59 N/mm ²
Support	126.5	46.2	0	46.2	< 54 N/mm ²

NOTE: (1) Stress in weld calculated as in 6.4.2 Part 10, eg at midspan

$$\text{Stress} = (47.2)(425)/1163 = 17.29 \text{ N/mm}^2$$

Appendix A

(2) Limiting stress range determined from figure 8(d) for class S. L is taken as 10.4 m at mid-span and 20.8 m at the support (see D.4.4 Part 10)

TABLE A9 FATIGUE CHECK FOR SHEAR CONNECTORS

C. DESIGN OF BEARING STIFFENERS

Effective Section

Provide single leg stiffener size 120 × 15 mm. The effective width of web acting as a stiffener is governed by the web thickness. Stiffener properties are as follows: ...Clause 9.14.2.1

Area = 13177 mm²

$I_x = 21.52 \times 10^6 \text{ mm}^4$

$I_y = 245 \times 10^6 \text{ mm}^4$

$Z_x = 1.67 \times 10^5 \text{ mm}^3$

$Z_y = 8.85 \times 10^5 \text{ mm}^3$

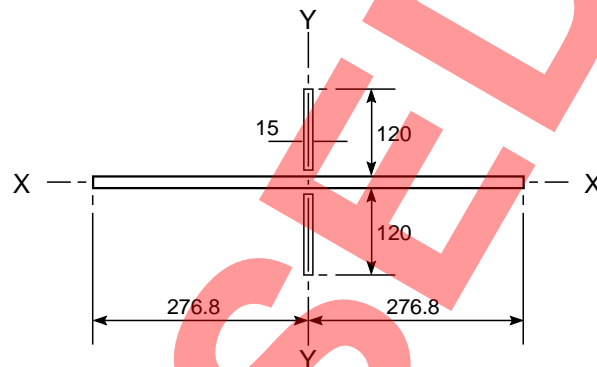

Loading

Load effects to 9.14.3.1 a, c, d and e are present as follows: ...Clause 9.14.3.1

- (1) Reaction = 1150.1 kN ...Table A2
- (2) Cross-beam weight say = 19.9 kN
- Total vertical force = 1170 kN
- (3) Mx = 22.8 kN m
- (3) My (assuming e as 25 mm) = 28.5 kN m

[Note: Mx is due to the U-frame action of the bearing stiffener and the cross-beam. Mx due to transverse beam at the support is very small and therefore ignored.]

$\sigma_{fc} = 4307 / (1.68 \times 10) = 256.4 \text{ N/mm}^2$...Clause 9.12.4.1

Since σ_{ci} is very large ($\lambda_{tT} = 0$) $F_1 = 0$

$F_2 = F_R = (2.5)(27.9)(305.5)(256.4)/100000 = 54.6 \text{ kN}$...Clause 9.12.4.1 (1)

$M_x = (54.6)(918.5-500)/1000 = 22.8 \text{ kN m}$

Yielding of web plate

Determine maximum equivalent stress σ_e from 9.13.5.1

$$\begin{aligned}\sigma_{es2} &= 1170/13.177 + (28.5)(276.8)/245 + (22.8)(8.65)/21.52 \\ &= 130.2 \text{ N/mm}^2\end{aligned}$$

$$\tau = 1170000/(918.5)(17.3) = 73.6 \text{ N/mm}^2$$

Unstiffened so no tension field action

therefore confirm that $\tau_o > \tau$

$\sigma_1 = 0$ for simply supported deck

$$\begin{aligned}\tau_o &= (3.6)(205000)(1 + (862.7/20800)^2)(17.3/862.7^2) && \dots\text{Clause 9.13.3.2} \\ &= 297.3 > 73.6 \text{ N/mm}^2\end{aligned}$$

$$\tau_R = 73.6 \text{ N/mm}^2$$

At support $\sigma_a = \sigma_b = 0$

$$\begin{aligned}\delta_e &= (130.2^2 + 3(73.6^2))^{1/2} && \dots\text{Clause 9.14.4.1} \\ &= 182.2 \text{ N/mm}^2 < 307.4 \text{ N/mm}^2 \quad [(355/(1.05)(1.1))]\end{aligned}$$

Stiffener is satisfactory

Yielding of stiffener

$$\begin{aligned}\text{Stress} &= 1170/13.177 + (28.5)(7.5)/245 + (22.8)(128.65)/21.52 && \dots\text{Clause 9.14.4.2} \\ &= 225.96 \text{ N/mm}^2 < 307.4 \text{ N/mm}^2\end{aligned}$$

Bearing stress

$$\text{Bearing length} = (2)(25 + 27.9)(1.732) + 50 = 233.2 \text{ mm}$$

$$\text{Contact Area} = 2(120-40\text{say})(15) + 233.2(17.3) = 6434 \text{ mm}^2 \quad \dots\text{Clause 9.14.4.2}$$

$$\begin{aligned}\text{Bearing stress} &= 1170000/6434 = 181.8 \text{ N/mm} \\ &< 306.6 \text{ N/mm}^2\end{aligned}$$

$$\begin{aligned}\text{Limiting stress} &= (1.33)(355)(.75)/(1.05)(1.1) && \dots\text{Clause 14.6.5} \\ &= 306.6 \text{ N/mm}^2\end{aligned}$$

The arrangement of stiffener is satisfactory.

Appendix A

Buckling of stiffener

Determine σ_{is}

$$l_s = 862.7 \text{ mm}$$

$$r_{se} = ((21.52)(10)^6 / (13177))^{1/2} = 40.41 \text{ mm}$$

$$\lambda = 862.7 / 40.41 = 21.4$$

$$\sigma_{is} = (0.94)(355) = 333.7 \text{ N/mm}^2$$

$$1170 / (13.177)(333.7) + 22.8 / (.167)(355) + 28.5 / (.885)(355) = 0.74$$

$$< 0.76$$

The stiffener section is satisfactory.

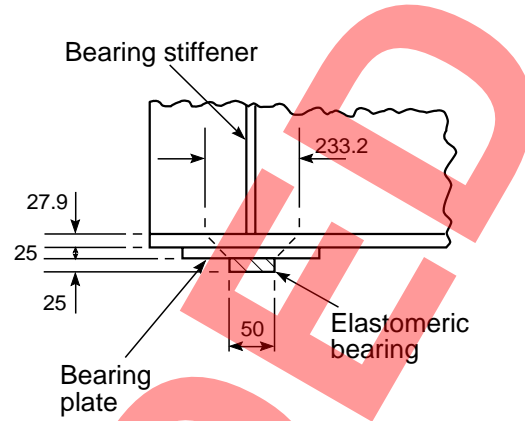

...Figure 23

...Clause 9.14.4.3

D. TRANSVERSE BEAM AT THE SUPPORT

The transverse beams at the supports are concrete beams (600x500) connecting the webs of the main beams. The loadings for the design are as follows:

Unfactored loads	Ultimate loads
self weight = 17.3 kN	1.15 x 17.3 = 19.9 kN
slab = 7.8 kN	1.15 x 7.8 = 9.0 kN
Surfacing = 3.5 kN	1.75 x 3.5 = 6.1 kN
Live load (HB locally placed)	
point load at midspan = 112.5 kN	1.3 x 112.5 = 146.3 kN
UDL = 103.1 kN	1.3 x 103.1 = 134 kN
Moment due to dead load (factored) = 10.0 kN m	
Moment due to live load (factored) = 105.5 kN m	
Total design moment = 115.5 kN m	
Total design shear = 119.3 kN	

The design of the concrete beam should be in accordance with BS 5400: Part 4 and the Departmental Standard BD 17/83.