

**SERIES 1700
STRUCTURAL CONCRETE**

Contents

Clause	Title	Page	Clause	Title	Page
1701	(12/14) Concrete – General	2	1726	(12/14) Stainless Steel Dowels – Materials	33
1702	(12/14) Concrete – Constituent Materials	2	1727	(12/14) Inspection and Testing of Structures and Components	34
1703	(12/14) Concrete – Exposure Classes	4	1728	(12/14) Geometrical Tolerances	34
1704	(12/14) Concrete – General Requirements	4	1729	(03/20) Post-Installed Anchors and Reinforcing Bar Connections	37
1705	(12/14) Concrete – Requirements for Designed Concrete	5			
1706	(12/14) Concrete – Production	5			
1707	(12/14) Concrete – Conformity and Identity Testing	6			
1708	(12/14) Concrete – Surface Finish	6			
1709	(03/20) Concrete – Surface Protection Systems	8			
1710	(12/14) Concrete – Construction General	15			
1711	(12/14) Concrete – Grouting and Duct Systems For Post-tensioned Tendons	23			
1712	(12/14) Reinforcement – Materials	27			
1713	(12/14) Carbon Steel Reinforcement and Stainless Steel Reinforcement – Bar Schedule Dimensions – Cutting and Bending	28			
1714	(12/14) Reinforcement – Fixing	28			
1715	(12/14) Reinforcement – Surface Condition	29			
1716	(12/14) Reinforcement – Laps and Joints	29			
1717	(12/14) Reinforcement – Welding	29			
1718	(12/14) Prestressing Tendons – Materials	30			
1719	(12/14) Prestressing Tendons – Handling and Storage	30			
1720	(12/14) Prestressing Tendons – Surface Condition	30			
1721	(12/14) Prestressing Tendons – Straightness	30			
1722	(12/14) Prestressing Tendons – Cutting	31			
1723	(12/14) Prestressing Tendons – Positioning of Tendons, Sheaths and Duct Formers	31			
1724	(12/14) Prestressing Tendons – Tensioning	31			
1725	(12/14) Prestressing Tendons – Protection and Bond	33			

STRUCTURAL CONCRETE

1701 (12/14) Concrete – General

(12/14) Specification of Concrete

1 (12/14) This Series is part of the Specification for Highway Works. Whilst this Series is particularly relevant to the subject matter in its title, it must be read in conjunction with the general requirements in Series 000 and 100 and with all other Series relevant to the Specification for the particular works to be undertaken.

2 (12/14) Concrete shall conform to the requirements of BS 8500 Parts 1 and 2. Unless otherwise described in contract specific Appendix 17/4, concrete shall be specified as designed concrete. The contract specific requirements for the structural concrete in the permanent works are given in contract specific Appendix 17/1.

(12/14) Designed Concrete

3 (12/14) The specification for designed concrete defined in BS 8500-1 shall be as described in this Specification and contract specific Appendix 17/1 and shall contain:

- (a) the basic requirements given in 4.3.2 of BS 8500-1;
- (b) the additional requirements given in 4.3.3 of BS 8500-1 where described in this Specification and contract specific Appendix 17/1.

(12/14) Implementation of BS EN 13670

4. (12/14) The execution of concrete structures shall be in accordance with BS EN 13670 as complemented by this Specification. The provisions of this Specification apply to both in situ and precast concrete, unless noted otherwise.

(12/14) Execution Class

5. (12/14) The works shall be built in accordance with Execution Class 3 as defined in BS EN 13670 unless otherwise described in contract specific Appendix 17/4.

(12/14) Inspection Requirements

6. (12/14) Inspection for materials and products and inspection for execution of works, as well as documentation of inspection, shall be in accordance with BS EN 13670 as complemented by this Specification. Requirements for the inspection and testing of structures are given in contract specific Appendix 17/4. Where described in Appendix 17/4 inspection of concrete works shall be executed by an organisation independent of the Contractor.

1702 (12/14) Concrete – Constituent Materials

(12/14) Cement and combinations

1 (12/14) Cement types as defined in BS 8500 (see Table A.6 of BS 8500-1 or Table 1 of BS 8500-2) shall comprise one of the following, unless otherwise described in contract specific Appendix 17/4:

CEM I, CEM II/A-S, CEM II/A-L, CEM II/A-LL, CEM II/A-D, CEM II/B-S, CEM II/A-V, CEM II/B-V, CEM III/A, CEM III/B, CEM IV/B and sulfate-resisting Portland cements CEM I-SR 0 and CEM I-SR 3 conforming to BS EN 197-1.

Combinations as defined in BS 8500 shall comprise one of the following, unless otherwise described in contract specific Appendix 17/4:

CI/A-S, CI/B-S, CI/A-L, CI/A-LL, CI/A-V, CI/B-V, CII/A, CII/B and CIV-B-V.

Cements shall conform to BS EN 197-1. Evidence of compliance with the harmonised part of BS EN 197-1 with respect to product performance shall be demonstrated by CE marking and a Declaration of Performance where the declared performance for the essential characteristics given in Annex ZA of that Standard is equal or greater than the performance level required for the intended use of the cement.

Ground granulated blastfurnace slag, fly ash and silica fume shall conform to BS EN 15167-1, BS EN 450-1 and BS EN 13263-1, respectively. Evidence of compliance with the harmonised part of those Standards with respect to product performance shall be demonstrated by CE marking and a Declaration of Performance where the declared performance for the essential characteristics given in Annex ZA of those Standards is equal or greater than the performance level required for the intended use of the constituent.

Limestone fines shall conform to BS 7979.

(12/14) **Aggregates**

2 (12/14) Unless otherwise specified in contract specific Appendix 17/4, aggregates shall conform to BS EN 12620 (for normal and heavy weight aggregates) and BS EN 13055-1 (for lightweight aggregates) and to the requirements of 4.3 of BS 8500-2 except that recycled concrete aggregate (RCA) and recycled aggregate (RA) shall not be used. Where the use of RCA or RA is proposed, it shall be subject to the approval of the Overseeing Organisation through its Departure from Standard processes.

Evidence of compliance with the harmonised part of BS EN 12620 and BS EN 13055-1 with respect to product performance shall be demonstrated by CE marking and a Declaration of Performance where the declared performance for the essential characteristics given in Annex ZA of that Standard is equal or greater than the performance level required for the intended use of the aggregate, with the System of Assessment and Verification of Consistency of Performance (AVCP) as defined in PD 6682-1 and PD 6682-4 for aggregates conforming to BS EN 12620 and BS EN 13055-1, respectively.

The flakiness index of the coarse aggregate when determined by the method described in BS EN 933-3 shall not exceed FI_{35} except when natural, uncrushed aggregates are used for concrete of strength classes lower than C32/40, when the flakiness index shall not exceed FI_{50} . No flakiness index limit is required for strength class C12/15 concrete or below.

When required, the resistance to fragmentation of the coarse aggregate, determined in terms of the Los Angeles coefficient as specified in BS EN 1097-2 and declared in accordance with the relevant category specified in Table 16 of BS EN 12620, shall meet the requirements for LA_{40} . Aggregates with LA coefficient values above 40 may also perform satisfactorily in normal concrete but their strength performance shall be established in concrete trials before use.

Chloride levels of aggregate shall be established from testing using the Volhard reference method in BS EN 1744-1, or other method calibrated against this reference method. Where the aggregate chloride level has been established as minimal, that is less than the detection level of 0.002%, typical for land based materials, then this value may be used. Where there is a significant chloride level, the value shall be established as set out in 5.2.7 of BS EN 206-1.

Aggregates shall be selected as to satisfy the requirements in sub-Clause 1704.5 for the control of alkali-silica reaction.

(12/14) **Admixtures and Pigments**

3 (03/20) Admixtures shall conform to BS EN 934-2 and shall comply with 4.5 of BS 8500-2 and the requirements of Clause 5 of BS EN 206-1 unless otherwise described in contract specific Appendix 17/4. Evidence of compliance with the harmonised part of BS EN 934-2 with respect to product performance shall be demonstrated by CE marking and a Declaration of Performance where the declared performance for the essential characteristics given in Annex ZA of that Standard is equal or greater than the performance level required for the intended use of the admixture. Where a specified coloured concrete requires a pigment, the pigment shall conform to BS EN 12878.

In all cases the Contractor shall record the following information, which shall be subsequently supplied to the Overseeing Organisation in accordance with the requirements of CG 302 'As built, Operational and Maintenance Records for Highway Structures' (DMRB 3.2.1):

- (a) the detrimental effects caused by adding a greater or lesser quantity of admixture or pigment;
- (b) the chemical name(s) of the main active ingredient(s);
- (c) whether or not the admixture leads to the entrainment of air.

(12/14) **Fibres for concrete**

4 (12/14) The use of fibres for concrete is not covered by this Specification. Where their use is proposed, it shall be subject to the approval of the Overseeing Organisation through its Departure from Standard processes.

1703 (12/14) Concrete – Exposure Classes

(12/14) **Selection of Exposure Classes**

1 (12/14) The exposure classes shall be as described in contract specific Appendix 17/1.

1704 (12/14) Concrete – General Requirements

(12/14) **Compressive Strength Class of Concrete**

1 (12/14) The compressive strength classes of concrete shall be as described in contract specific Appendix 17/1.

(12/14) **Minimum Cement Content and Maximum Water/Cement Ratio**

2 (12/14) The cement content shall be not less than, and the water/cement ratio shall be not greater than, the values described in contract specific Appendix 17/1.

(12/14) **Maximum Cement Content**

3 (12/14) The cement content shall not exceed 550 kg/m³ unless otherwise described in contract specific Appendix 17/1.

(12/14) **Maximum Chloride Content**

4 (12/14) The chloride content class shall conform to the following requirements:

TABLE 17/1: (12/14) Chloride content classes

Type or use of concrete	Chloride content class	Maximum total chloride content expressed as % of chloride ion by mass of cement (inclusive of ggbs or fly ash when these are used as cement)
Prestressed concrete, heat-cured concrete containing embedded metal	Cl 0,10	0.10%
Concrete containing embedded metal and made with sulfate-resisting Portland cements CEM I-SR 0 and CEM I-SR 3 conforming to BS EN 197-1	Cl 0,20	0.20%
Concrete containing embedded metal and made with other permitted cements	Cl 0,30	0.30%

(12/14) **Control of Alkali-Silica Reaction**

5 (12/14) The provisions given in 5.2 of BS 8500-2 shall be applied to minimize damaging alkali-silica reaction. Extremely reactive aggregates, comprising those aggregates containing detectable quantities of opal, glass and calcined flint, shall not be used alone or in combination with other aggregates. The definition of rock types shall be as in BS EN 932-3.

(12/14) **Buried Concrete Exposed to Sulfates**

6 (12/14) Choice of concrete and additional protective measures (APMs) shall comply with the requirements of BS 8500-1 for the design chemical (DC) class described in contract specific Appendix 17/1.

(12/14) **Early Thermal Cracking**

7 (12/14) The execution of concrete structures shall conform to the assumptions made in the design to control early thermal cracking and described in contract specific Appendix 17/1, unless otherwise agreed with the Overseeing Organisation.

(12/14) **Cover to Reinforcement**

8 (12/14) The Contractor shall provide certificates of compliance with respect to cover to reinforcement and detailed records of measured covers to the Overseeing Organisation before concrete is placed.

1705 (12/14) Concrete – Requirements for Designed Concrete

(12/14) **Conformity Criteria**

1 (12/14) The conformity criteria for a concrete shall be in accordance with BS EN 206-1 and BS 8500.

(12/14) **Suitability of Proposed Constituent Material Proportions**

2 (03/20) The Contractor shall record, prior to the supply of any designed concrete, the following information which shall be subsequently supplied to the Overseeing Organisation in accordance with the requirements of CG 302:

- (i) the nature and source of each material;
- (ii) either:
 - (a) appropriate existing data as evidence of satisfactory previous performance for target mean strength, current margin, consistence and water/cement ratio; or
 - (b) full details of initial tests carried out in accordance with Annex A of BS EN 206-1;
- (iii) the quantities of each constituent material per cubic metre of fully compacted concrete.

Assessment of the concrete in accordance with this sub-Clause shall be carried out for each different source of material and for any change in the quantities of each constituent material (except for changes in cement content of not more than 20 kg/m³ and pro-rata changes in aggregate contents where a single assessment is required).

1706 (12/14) Concrete – Production

(12/14) **Production Control**

1 (12/14) All concrete produced shall be subject to production control, as specified in Clause 9 of BS EN 206-1 and Clause 13 of BS 8500-2, and in accordance with the requirements of Clause 104.

(12/14) **Consistence At Delivery**

2 (12/14) In general water or admixtures shall not be added to concrete delivered to site following initial mixing in accordance with the mix design. Water or admixtures may only be added in special circumstances under the direction of the concrete producer and used to bring the consistence to the specified value provided that the limiting values, permitted by the Specification, are not exceeded. The quantity of any additional water or admixture added to the mix shall be recorded on the delivery ticket in all cases along with name of the organisation and person authorising the additions and the record of sub-Clause 1705.2 shall be amended accordingly.

(12/14) **Self-Compacting Concrete (SCC)**

3 (12/14) The use of SCC is not covered by this Specification. Where the use of SCC is proposed, it shall be subject to the approval of the Overseeing Organisation through its Departure from Standards processes.

1707 (12/14) Concrete – Conformity and Identity Testing

(12/14) **General**

1 (12/14) Sampling and testing of fresh and of hardened concrete shall comply with BS EN 206-1 unless otherwise described in contract specific Appendix 17/4, and shall be as scheduled in contract specific Appendices 1/5 and/or 1/6 as appropriate, in accordance with Clause 105.

(12/14) **Identity Testing**

2 (12/14) Where identity testing for compressive strength is required, as described in contract specific Appendix 17/4, it shall be in accordance with the requirements given in Annex B of BS EN 206-1 and Annex B of BS 8500-1. Where identity testing for slump, flow, air content and density on individual batches of concrete is required, as described in contract specific Appendix 17/4, it shall be in accordance with Annex B of BS 8500-1. Identity testing shall be as scheduled in contract specific Appendix 1/5 and/or 1/6.

1708 (12/14) Concrete – Surface Finish

(12/14) **Trial Panels**

1 (12/14) When required in contract specific Appendix 17/3 and before commencing concrete works the Contractor shall prepare a trial panel of a suitable size that will demonstrate that the required surface finish can be achieved by the methods proposed.

The panel of concrete shall contain reinforcement representative of the reinforcement sizes and spacings in the sections of the permanent works the panel represents and shall be filled with the concrete proposed for the works the trial panel relates to compacted by the method to be used in the works. As soon as practicable after compaction, the formwork shall be removed to check that the required surface finish and compaction has been achieved.

Reference panels have also been produced showing typical Class F2 and F4 surface finishes made with local materials in each region of the UK and they can be viewed at various sites throughout the UK.

(12/14) **Control of Colour**

2 (12/14) When stated in contract specific Appendix 17/1 each constituent material shall be obtained from a single consistent source. The aggregates shall be free of any impurities that may cause staining. The mix proportions and the grading, particularly of the sand (i.e. fine aggregate), shall be maintained constant. The same type of formwork facing material, surface finish and surface treatments shall be used in formwork throughout similar exposed areas.

(12/14) **Release Agents**

3 (12/14) Release agents for the formwork shall enable the formwork to be removed without damage to the concrete surface. Where a concrete surface is to be permanently exposed, only one agent shall be used throughout the entire area. Release agents shall be applied evenly and shall not be permitted to come into contact with reinforcement, prestressing tendons and anchorages; contamination from release agents shall be removed from such areas.

Where the concrete is to receive an applied finish, or surface impregnation, release agents shall be compatible with the particular material and any associated process.

(12/14) **Surface Finishes for Concrete**

4 (i) (12/14) Formed Surfaces – Classes of Finish

Formwork as described in sub-Clause 1710.2 shall be capable of producing the following finishes where required in the works:

Class F1. A dense finish with no grout or mortar loss with the specified cover to embedded metal and achieving the specified dimensional tolerances.

Class F2. As the requirements of F1 and the irregularities in the finish shall be no greater than those obtained from the use of wrought thickened square edged boards arranged in a uniform pattern. The finish is intended to be left as struck but imperfections such as fins and surface discolouration shall be made good.

Class F3. As the requirements of F1 and the resulting finish shall be smooth and of uniform texture and appearance. The formwork lining shall leave no stain on the concrete and shall be so joined and fixed to its backing that it imparts no blemishes. It shall be of the same type and obtained from only one source throughout any one structure. The Contractor shall make good any imperfections in the finish. Internal ties and embedded metal parts shall not be used.

Class F4. The requirements for Class F4 are as for Class F3 except that internal ties and embedded metal parts shall be permitted. The ties shall be positioned only in rebates or in other positions as described in contract specific Appendix 17/3.

Class F5. The resulting finish shall be smooth and of uniform texture. Any blemishes and imperfections, such as discolouration and fins, shall be made good. Provision for the embedment of metal parts in the permanent works on a regular spacing, shall be allowed.

Other Classes. The finishes shall comply with the specific requirements described in contract specific Appendix 17/3.

Permanently exposed concrete surfaces to all Classes of finish other than F1 shall be protected from rust marks and stains of all kinds.

Unless otherwise described in contract specific Appendix 17/3, all formwork joints for all classes of finish other than F1 shall form a regular pattern with horizontal and vertical lines continuous throughout each structure and all construction joints shall coincide with these horizontal or vertical lines.

(ii) (12/14) Unformed Surfaces – Classes of Finish

Class U1 finish. The concrete shall be levelled and screeded to produce a uniform surface to the profile shown on the drawings. No further work shall be applied to the surface unless it is used as a first stage for another class of finish.

Class U2 finish. After the concrete has hardened sufficiently, the Class U1 finish shall be floated by hand or machine sufficiently only to produce a uniform surface free from screed marks.

Class U3 finish. When the moisture has disappeared and the concrete has hardened sufficiently to prevent laitance from being worked to the surface, a Class U1 finish shall be steel-trowelled under firm pressure to produce a dense, smooth uniform surface free from trowel marks.

Class U4 finish. The concrete shall be levelled and screeded to produce a uniform surface. When the concrete has sufficiently hardened and the bleed water evaporated the surface shall be trowelled to produce a hard dense surface free from screed marks and exposed aggregate. Finally the surface shall be lightly textured with a wooden float or equivalent. Alternatively the concrete shall be levelled, screeded and floated to produce a uniform surface and immediately before the waterproofing operation this surface shall receive surface preparation by water jetting or grit blasting to provide a lightly textured finish. The finished surface shall not deviate from the required profile by more than 10 mm over a 3 m gauge length or have any abrupt irregularities more than 3 mm.

Class U5 finish. The concrete shall be levelled and screeded to produce a uniform finish. When the concrete has sufficiently hardened to prevent laitance being worked to the surface it shall be floated to produce a surface free from screed marks and exposed aggregate. Finally the surface shall be textured to suit the requirements of the particular waterproofing and surfacing system. The accuracy of the finished surface shall be such that it does not deviate from the required profile by more than 5 mm over a 3 m gauge length or have any abrupt irregularities.

Other Classes. The finishes shall comply with the specific requirements described in contract specific Appendix 17/3.

1709 (03/20) Concrete – Surface Protection Systems

(03/20) General Requirements

- 1 (i) (03/20) The structural concrete elements receiving surface protection systems shall be as specified in contract specific Appendix 17/2.
- (ii) The Contractor shall submit details of the surface protection system products to the Overseeing Organisation for acceptance at least 4 weeks prior to commencing the surface protection works.
- (iii) Special requirements or constraints to the application of surface protection systems shall be as detailed in contract specific Appendix 17/2.
- (iv) The Contractor shall include details of the surface protection system and its application in the quality plan and method statement submitted to the Overseeing Organisation in accordance with Clause 104 and as specified in contract specific Appendix 1/24.
- (v) Contaminated materials, protective sheeting or masking that have come into contact with surface protection system products shall be disposed of at an appropriate disposal facility.
- (vi) Surface protection system products used in combination with other surface protection system products shall be compatible with each other and applied in complementary combinations.
- (vii) Surface protection systems shall be clear and colourless following application to the concrete substrate.

(03/20) Supply, Storage and Disposal of Surface Protection Systems

- 2 (i) (03/20) The Contractor shall implement processes for delivery, handling, disposal and spillage of surface protection systems such that all safety, environmental and specification requirements are met. Details of these processes shall be included in the quality plan and method statement as required in sub-Clause 1709.1(iv) and shall include the requirements of paragraphs (ii) to (x) of this sub-Clause.
- (ii) Surface protection system products shall be delivered to site in individual sealed containers or in a bulk container. Product and container markings shall be examined upon delivery to site to ensure they are within the manufacturer's stated use by dates for the duration of the works.
- (iii) The delivery dates for surface protection system products shall be recorded.
- (iv) Surface protection system products shall be stored in a controlled environment in accordance with the manufacturer's recommendations and BS EN 1504-10.
- (v) Quantities of surface protection system products used for the works shall be monitored on site.

- (vi) Containers shall remain sealed until their contents are required for use.
- (vii) The contents of any opened containers shall be used within the time limits in accordance with the manufacturer's instructions.
- (viii) Any unused content of opened containers exceeding the time limits in accordance with the manufacturer's instructions must be disposed of in accordance with the Control of Substances Hazardous to Health Regulations (COSHH).
- (ix) If spillages of surface protection system products occur, the Contractor shall take immediate action to limit the extent of the spillage in accordance with the manufacturer's instructions.
- (x) The Contractor shall inform the Overseeing Organisation and relevant responsible authorities of the spillage without delay.

(03/20) Surface Protection Systems – Substrate Preparation

- 3**
- (i) (03/20) The concrete substrate shall be cleaned and prepared in accordance with the manufacturer's instructions and BS EN 1504-10.
 - (ii) The concrete substrate shall be free from defects prior to the application of the surface protection system.
 - (iii) Where concrete repairs to defects are to be undertaken these shall be executed, prior to the application of the surface protection system, in accordance with Series 5700.
 - (iv) The concrete substrate shall be free from contaminants, such as dust, dirt, oil and laitance, which might affect the adhesion of the surface protection system to the substrate.
 - (v) Where hydrophobic impregnation products are to be applied, artificial drying of the concrete surface shall not be permitted.
 - (vi) Where there is delay between cleaning and the application of the surface protection system, the cleaned substrate shall be protected from further contamination.

(03/20) Hydrophobic Impregnation – General

- 4**
- (i) (03/20) Hydrophobic impregnation products shall conform to BS EN 1504 parts 1, 2, 8, 9 and 10.
 - (ii) Hydrophobic impregnation shall protect the concrete substrate against diffusion of chloride ions.

(03/20) Hydrophobic Impregnation – Materials

- 5**
- (i) (03/20) The performance requirements for hydrophobic impregnation shall be as specified in contract specific Appendix 17/2. The performance requirements for specific performance characteristics of Table 3 of BS EN 1504-2 shall be in accordance with Table 17/2.

TABLE 17/2 (03/20) Performance Requirements for Hydrophobic Impregnation

BS EN 1504-2 Table 3 ref	Performance Characteristics	Test Method	Requirements
17	Loss of mass due to freeze-thaw	BS EN 13581	The loss of mass of the surface of the impregnated specimen must occur at least 20 cycles later than that of the non-impregnated specimen
19	Depth of penetration	Specified in Table 3 of BS EN 1504-2	class II: $\geq 10\text{mm}$
23	Water absorption and resistance to alkali test	BS EN 13580	Absorption ratio (after immersion in alkali solution) $< 10\%$
25	Diffusion of chloride ions	Subject to national standards and national regulations: test detailed in sub-Clause 1709.6	Sub-Clause 1709.6(vi).

- (ii) Evidence of compliance with the harmonised part of BS EN 1504-2 with respect to product performance shall be demonstrated by CE marking and a Declaration of Performance where the declared performance for the essential characteristics given in Annex ZA of that Standard is equal or greater than the performance level required for the intended use of the product and the specification.

(03/20) Hydrophobic Impregnation – Test to Determine Resistance to Diffusion of Chloride Ions

- 6 (i) (03/20) Principle of test. The chloride profiles of treated and untreated concrete slabs shall be compared after ponding the top surface of the slabs with salt solution fortnightly for 15 cycles.
- (ii) Casting of test specimens. The test specimens shall be 450mm x 450mm x 100mm deep, and shall be cast upside down with an insert in the base of the mould which forms a recess for treatment and subsequent ponding, as shown in Figure 17/1. Four specimens shall be cast in accordance with BS EN 1766 using Type C concrete as specified in that Standard. The specimens shall be cured in their moulds under damp hessian for 24 hours and then demoulded. Thereafter the specimens shall be cured under damp hessian for a further 6 days and then air-cured in the laboratory.

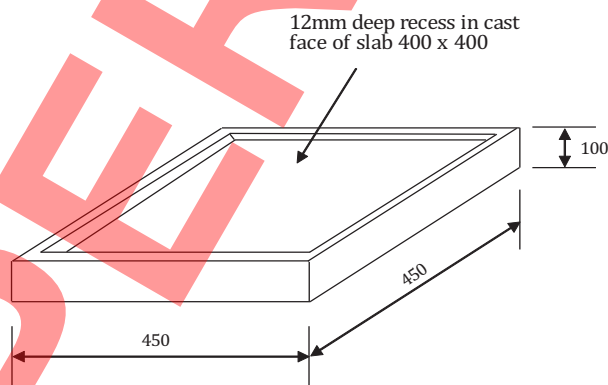

All dimensions in millimetres

Figure 17/1 (03/20) Details of Test Specimen

- (iii) Treatment of the specimens. The top surface of two of the specimens shall be treated with the hydrophobic impregnation product at least 28 days after casting, and the other two shall be used as untreated control specimens. The specimens shall be treated in a fume cupboard to avoid cross contamination of the untreated specimens. After treatment, the specimens shall be kept in the fume cupboard with the fan turned off for a minimum of 48 hours before being moved into the laboratory. The volume or weight of hydrophobic impregnation product required to cover the treated surface of the specimens shall be calculated, and the product shall be applied to the specimens in accordance with the manufacturer's instructions and with the following:
- (a) When liquid hydrophobic impregnation products are used, the required volume or weight of product shall be poured over the test surface of each specimen, and spread with the base of a small beaker to ensure that the whole surface is completely wetted.
- (b) When cream or gel hydrophobic impregnation products are used, they shall be applied using a small roller. The roller shall first be charged with the product and weighed. The product shall then be applied uniformly to the test surface by passing the roller over the surface. The roller shall then be weighed to establish the amount of product that has been applied. If required, additional product can be applied with further passes of the roller until the target application rate is achieved. Trials on spare specimens shall be carried out to establish how much product is required to achieve the specified application rate.
- (iv) Ponding the specimens. The treated and untreated specimens shall be stored on a level surface in a laboratory maintained at a temperature between 10°C and 25°C and ponded fortnightly for 15 cycles. For each ponding cycle, one litre of 5% sodium chloride solution by weight shall be poured into the recessed test area of each slab. The solution will dry off after a few days and the next cycle shall commence 14 days after the first application of the salt solution.
- (v) Chloride profiles. After 15 cycles, a single 50mm diameter core with a minimum depth of 60mm shall be removed from the ponded surface of each slab. The cores shall be removed a minimum of 100mm from the edges of the slabs. Dust samples shall be obtained by sawing the cores at depths of 5mm, 10mm and 15mm from the ponded surface and then grinding the slices to produce dust samples. For each increment, the dust samples from the treated and untreated pairs of slabs shall be combined to form a single sample. The chloride concentration of each of the dust samples shall be determined in accordance with BS 1881 Part 124.
- (vi) Requirement. For each increment, the percentage reduction (PR) in chloride ion concentration in the treated slabs (Ct) compared with the chloride ion concentration in the untreated slab (Cu), given by $PR (\%) = 100 * (Cu - Ct) / Cu$, shall be calculated. In order for the hydrophobic impregnation product to be acceptable for use, the percentage reduction in chloride ion concentration shall be greater than 75% for the 0-5mm increment, and greater than 90% for the 5-10mm and 10-15mm increments.

(03/20) **Hydrophobic Impregnation – Testing**

- 7 (i) (03/20) When transparent liquid hydrophobic impregnation products are used, the Contractor shall demonstrate that they have not been contaminated by the following procedure, and as specified in contract specific Appendix 17/2:
- (a) The refractive index of the hydrophobic impregnation product shall be tested as follows:
- collect samples from each of the newly opened containers and from the spraying nozzle;
 - measure the refractive index of three samples from each of the containers and the spray nozzle using a portable refractometer;
 - record the ambient temperature;
 - correct the refractive index measurements to the temperature stated in the manufacturer's product specification.

- (b) The measured value for each batch of the hydrophobic impregnation product shall comply with the following:
 - value stated in the manufacturer's product information;
 - within a limit of 0.003 units of each other.
- (ii) Before the commencement of the works the Contractor shall demonstrate by procedure trials the suitability of the proposed product, the method of working and the competence of the proposed operatives executing the application as follows, and as specified in contract specific Appendix 17/2:
 - (a) construct small trial concrete panels on both vertical and horizontal surfaces replicating substrate on site, with minimum dimensions 3m x 3m;
 - (b) the operative shall apply the hydrophobic impregnation product to the trial panels in accordance with the method statement;
 - (c) the proposed rate of application shall achieve saturation (for liquids) or result in an evenly applied material over the concrete surface (for gels and creams).

(03/20) **Hydrophobic Impregnation – Application**

- 8
- (i) (03/20) Protective measures to prevent contamination of watercourses and damage to humans, animals, vegetation and vehicles from the hydrophobic impregnation shall be implemented prior to the application of the product.
 - (ii) Where hydrophobic impregnation is applied on structures over or adjacent to roads or railways, protective sheeting or complete encapsulation, as well as safety measures shall be implemented.
 - (iii) Elastomeric bearings, painted steel surfaces, bituminous materials and joint sealants shall be protected during the application of hydrophobic impregnation, with the protective measures maintained in positions and good condition.
 - (iv) Hydrophobic impregnation shall not be applied until the concrete surface has been dry for 24 hours.
 - (v) The hydrophobic impregnation product shall be applied in accordance with the manufacturers' instructions and safety information and the method statement.
 - (vi) Each application of the hydrophobic impregnation product on the face of a structural element shall be executed in a single continuous operation.
 - (vii) Unless otherwise stated by the manufacturer's instructions, hydrophobic impregnation shall be carried out not less than 7 days after the concrete has been placed, or 3 days after concrete repairs have been completed on a structural element.
 - (viii) Unless otherwise stated by the manufacturer's instructions, hydrophobic impregnation shall not be carried out in the following conditions:
 - (a) when the shade temperature is below 5°C;
 - (b) when the temperature of the concrete surface is lower than 5°C or greater than 25°C;
 - (c) when the shade temperature is less than 3°C above dew point;
 - (d) when the wind speed is in excess of 8 km/hr, unless the working area is fully encapsulated.
 - (ix) The treated concrete substrate shall be protected from rain and spray during application and for at least six hours after completion or in accordance with the manufacturer's instructions, whichever is the later.

(03/20) **Anti-Graffiti Coatings – General**

- 9
- (i) (03/20) Anti-graffiti coatings shall conform to BS EN 1504 parts 1, 2, 8, 9 and 10.
 - (ii) Anti-graffiti coatings shall allow graffiti on treated areas of concrete structures to be removed without damage to the concrete substrate.
 - (iii) Anti-graffiti coatings shall not noticeably change the appearance of the substrate to which they are applied.

(03/20) **Anti-Graffiti Coatings – Materials**

- 10 (i) (03/20) The performance requirements for anti-graffiti coatings shall be as specified in contract specific Appendix 17/2. The performance requirements for specific performance characteristics of Table 5 of BS EN 1504-2 shall be in accordance with Table 17/3.

TABLE 17/3 (03/20) Performance Requirements for Anti-graffiti Coatings

BS EN 1504-2 Table 5 ref	Performance Characteristics	Test Method	Requirements
7	Permeability to water vapour	BS EN ISO 7783-1 BS EN ISO 7783-2	class I $s_D < 5m$ (permeable to water vapour)
15	Adhesion strength by pull-off test	BS EN 1542	Average [N/mm ²] Crack-bridging or flexible systems Rigid systems ^c without trafficking $\geq 0.8 (0.5)^b$ $\geq 1.0 (0.7)^b$

^b The value in brackets is the lowest accepted value of any reading

^c Rigid coatings are coatings with shore D ≥ 60 according to BS EN ISO 868

- (ii) Evidence of compliance with the harmonised part of BS EN 1504-2 with respect to product performance shall be demonstrated by CE marking and a Declaration of Performance where the declared performance for the essential characteristics given in Annex ZA of that Standard is equal or greater than the performance level required for the intended use of the product and the specification.

(03/20) **Anti-Graffiti Coatings – Testing**

- 11 (03/20) The Contractor shall demonstrate by procedure trials the suitability of the proposed product, the method of working and the competence of the proposed operatives executing the application of the anti-graffiti coating as follows, and as specified in contract specific Appendix 17/2:
- (i) construct small trial concrete panels replicating substrate on site, with minimum dimensions 3m x 3m;
 - (ii) the operative shall apply the anti-graffiti coating to the trial panels in accordance with the method statement;
 - (iii) the appearance of the trial panel following application of the anti-graffiti coating shall not have been noticeably altered;
 - (iv) graffiti shall be applied to the treated trial panels and allowed to cure;
 - (v) once the graffiti is cured, cleaning of the trial panels shall be undertaken to demonstrate the removal of graffiti without damage to the concrete substrate.

(03/20) **Anti-Graffiti Coatings – Application**

- 12 (i) (03/20) Application of the anti-graffiti coating shall be in accordance with the manufacturer's instructions.
- (ii) Where repairs to the concrete are carried out prior to the application of the coating, the subsequently applied coating shall be compatible with the concrete substrate, the repair materials used and any other surface protection system product applied.
- (iii) Finished surfaces shall be protected to prevent early and irreparable defacement in accordance with the manufacturer's instructions, or for five days after application of the final coat, whichever is the later.

(03/20) **Anti-Carbonation Coatings – General**

- 13 (i) (03/20) Anti-carbonation coatings shall conform to BS EN 1504 parts 1, 2, 8, 9 and 10.
 (ii) Anti-carbonation coatings shall protect the concrete structure against carbon dioxide ingress and the consequential carbonation of the substrate.

(03/20) **Anti-Carbonation Coatings – Materials**

- 14 (i) (03/20) The performance requirements for anti-carbonation coatings shall be as specified in contract specific Appendix 17/2. The performance requirements for specific performance characteristics of Table 5 of BS EN 1504-2 shall be in accordance with Table 17/4.

TABLE 17/4 (03/20) Performance Requirements for Anti-Carbonation Coatings

BS EN 1504-2 Table 5 ref	Performance Characteristics	Test Method	Requirements
6	Permeability to CO ₂	BS EN 1062-6 (Conditioning of the samples before testing should be in accordance with BS EN 1062-11 4.3)	Permeability to CO ₂ S _D > 50m
7	Permeability to water vapour	BS EN ISO 7783-1 BS EN ISO 7783-2	class I s _D < 5m (permeable to water vapour)
8	Capillary absorption and permeability to water	BS EN 1062-3	w < 0.1 [kg/m ²] h ^{0.5}
15	Adhesion strength by pull-off test	BS EN 1542	Average [N/mm ²] Crack-bridging or flexible systems Rigid systems ^c without trafficking ≥ 0.8 (0.5) ^b ≥ 1.0 (0.7) ^b with trafficking ≥ 1.5 (1.0) ^b ≥ 2.0 (1.5) ^b
9	Adhesion after thermal compatibility For outside application with de-icing salt influence	BS EN 13687-1 and BS EN 13687-2	After thermal cycling a) no bubbles, cracks and delamination b) pull of test results Average [N/mm ²] Crack-bridging or flexible systems Rigid systems ^c without trafficking ≥ 0.8 (0.5) ^b ≥ 1.0 (0.7) ^b with trafficking ≥ 1.5 (1.0) ^b ≥ 2.0 (1.5) ^b
13	Crack bridging ability	BS EN 1062-7	The required classes and the test conditions are given in Tables 6 and 7 of BS EN 1504-2
20	Artificial weathering	BS EN 1062-11	After 2000 hours of artificial weathering: no blistering according to BS EN ISO 4628-2 no cracking according to BS EN ISO 4628-4 no flaking according to BS EN ISO 4628-5 Slight colour change, loss of gloss and chalking may be acceptable, but shall be described.

^b The value in brackets is the lowest accepted value of any reading

^c Rigid coatings are coatings with shore D ≥ 60 according to BS EN ISO 868

- (ii) Evidence of compliance with the harmonised part of BS EN 1504-2 with respect to product performance shall be demonstrated by CE marking and a Declaration of Performance where the declared performance for the essential characteristics given in Annex ZA of that Standard is equal or greater than the performance level required for the intended use of the product and the specification.

(03/20) Anti-Carbonation Coatings – Application

- 15** (i) (03/20) Application of the anti-carbonation coating shall be in accordance with the manufacturer's instructions.
- (ii) Where repairs to the concrete are carried out prior to the application of the coating, the subsequently applied coating shall be compatible with the concrete substrate, the repair materials used and any other surface protection system product applied.

(03/20) Surface Protection Systems – Records

16 (03/20) Following the application of the surface protection system, a comprehensive record shall be prepared by the Contractor, subsequently supplied to the Overseeing Organisation in accordance with the requirements of CG 302 (DMRB 3.2.1), incorporating the following information as a minimum:

- (i) As-built records showing extents of the surface protection systems application;
- (ii) all relevant technical literature relating to the surface protection system products used;
- (iii) application method;
- (iv) contract compliance test findings;
- (v) amount of materials used;
- (vi) number of applications;
- (vii) coverage rate;
- (viii) weather conditions;
- (ix) maintenance requirements;
- (x) removal requirements.

1710 (12/14) Concrete – Construction General

(12/14) Construction Joints

1 (12/14) The position of construction joints shall be as shown on the drawings and at additional positions determined by the Contractor in accordance with the requirements of contract specific Appendix 17/4. When concrete is placed in vertical members, walls, columns and the like, the lifts of concrete shall finish level or, in sloping members, at right angles to the axis of the members, and the joint lines shall match features of the finished work, if possible, or be formed by grout checks. Kickers shall be constructed integrally with the lift of concrete below.

Concreting shall be carried out continuously up to construction joints.

Unless interface shear calculations in accordance with BS EN 1992-2 (Clause 6.2.5 of BS EN 1992-1-1) show that a non-prepared surface between concrete cast at different times is sufficient for structural purposes, construction joints shall be prepared in either of the following ways:

- (i) When the concrete is self-supporting but still sufficiently green, the formwork shall be removed, as necessary to expose the construction joint, subject to the requirements of sub-Clause 5 of this Clause. The concrete surface shall be sprayed with a fine spray of water or brushed with a stiff brush, just sufficiently to remove the outer mortar skin and expose the larger aggregate without disturbing it. Alternatively where this preparation proves impracticable the hardened surface skin and laitance shall be removed by grit blasting or a needle gun. Hardened surfaces shall not be hacked.

- (ii) By the use of proprietary steel open-mesh permanent formwork intended for use in construction joints.

Retarding agents shall not be used unless permitted in contract specific Appendix 17/4.

The joint surface shall be clean and damp but free of standing water immediately before any fresh concrete is placed against it.

(12/14) **Falsework and Formwork**

- 2 (i) (12/14) Design and construction. The formwork shall be sufficiently rigid and tight to prevent loss of grout or mortar from the concrete at all stages and for the appropriate method of placing and compacting. The falsework and formwork shall be so arranged as to be readily dismantled and removed from the cast concrete without shock, disturbance or damage.

Where necessary, the falsework and formwork shall be so arranged that the soffit form, properly supported on props only, can be retained in position for such period as may be required by maturing conditions as described in sub-Clause 1710.4(ii). If the component is to be prestressed whilst still resting on the soffit form, provision shall be made to allow for elastic deformation and any variation in weight distribution. Where it is intended to re-use formwork it shall be thoroughly cleaned and made good.

Internal metal ties which require being withdrawn through hardened concrete shall not be used where either face is permanently exposed. Where internal ties are left in, they shall be provided with a mortar cover of at least 50 mm. The jointing faces of the pocket shall be prepared with an exposed aggregate finish and dampened immediately prior to mortar filling.

- (ii) (12/14) Cleaning and treatment of forms. The faces of the forms in contact with the concrete shall be clean and treated with a suitable release agent, where applicable as described in sub-Clause 1708.3. Immediately before concreting, all forms shall be thoroughly cleaned out. The source of any compressed air used for the clearing of foreign matter from formwork shall be free from oil and other contaminant.
- (iii) (12/14) Projecting reinforcement and fixing devices. Where holes are needed in forms to accommodate projecting reinforcement or fixing devices, care shall be taken to prevent loss of grout when concreting or damage when striking forms.
- (iv) (03/20) Permanent formwork or special formwork shall comply with contract specific Appendix 17/4. When reinforced concrete plank permanent formwork (floor plates) is used, it shall comply with BS EN 15050 and contract specific Appendix 17/7, as described in sub-Clause 1710.8.

Gaps between permanent formwork units shall be adequately sealed to prevent leakage through the gaps.

For composite steel and concrete structures where permanent formwork is used, a suitable compressible construction seal shall be placed between the steel member and the permanent formwork where they overlap, to prevent leakage of grout during subsequent concreting operations. On completion of the curing of the concrete a suitable proprietary adhesive sealant shall be placed along the external interface between the steelwork and the permanent formwork to prevent ingress of moisture. The sealant shall be compatible with the surfaces it will be in contact with and shall have comparable durability to the corrosion protection to the steelwork. In the case of the use of weather resistant steels no sealant shall be provided.

Profiled steel sheeting (PSS) permanent formwork systems shall not contain indentations which may form a shear connection with the in-situ concrete, unless otherwise specified in contract specific Appendix 17/4. Protective treatment on edges and adjacent surfaces, including the edges of PSS which have been damaged by cutting, shall be restored to meet the contract specific requirements or an equivalent level of corrosion protection durability, in accordance with Series 1900.

Only single skin panels, either flat sheet or corrugated, shall be used for glassfibre reinforced concrete (GRC) permanent formwork. Polystyrene formers shall not be used in the corrugations of GRC permanent formwork.

When ribbed glass reinforced polymer (GRP) permanent formwork is used, there shall be no filler materials such as expanded polystyrene placed between the GRP ribs, which would prevent full contact between the deck concrete and the surface of the ribbed panels.

Permanent formwork panels which have dimensions that do not comply with manufacturers' dimensional tolerances shall not be used in the works. Damaged panels including those that are cracked, split or have, in the case of the GRP type, exposed steel in the ribs, shall not be used in the works.

Formwork panels shall be thoroughly cleaned to remove all traces of oil or grease. Any glass fibre reinforced cement (GRC) panel which cannot be cleaned by following the manufacturers' recommendations shall be replaced.

(12/14) Transporting, Placing and Compacting

3 (03/20) Concrete shall be transported and placed so that contamination, segregation or loss of the constituent materials does not occur, in accordance with Clause 14 of BS 8500-2.

Concrete, when deposited, shall have a temperature of not less than 5°C. Where the concrete is made using CEM I or a CEM II/A cement the concrete temperature shall not be more than 30°C. Where the concrete is made using a CEM II/B or a CEM III cement, or equivalent combination, the concrete temperature shall not be more than 35°C. The temperature of fresh concrete shall be measured in accordance with BS 8500-2. Fresh concrete shall not be placed against in situ concrete that has been in position for more than 30 minutes unless a construction joint is formed as described in sub-Clause 1 of this Clause.

Where lightweight aggregate concrete is to be pumped, the Contractor shall demonstrate to the satisfaction of the Overseeing Organisation that pumping will have no significant effect on the strength of the hardened concrete.

No concrete shall be placed in flowing water. Underwater concrete shall be placed in position by tremies or by pipelines using methods to ensure the requirements of this Specification are met.

When concreting bridge decks of substantial thickness to avoid layering of concrete, the whole thickness shall be placed in one pass. In deck slabs where void formers are used, adequate means to prevent flotation shall be employed and care taken to ensure adequate compaction of the concrete placed beneath the void formers; joints between adjacent units, or units and form faces shall be sealed to prevent loss of grout.

Where the minimum dimension of a concrete section to be placed at a single time is greater than 600mm measures shall be taken to reduce the adverse affects of high temperatures in the concrete or to reduce the temperature of concrete to prevent high temperatures having an adverse effect on the finished concrete.

Concreting operations shall not displace reinforcement, tendon ducts, tendon anchorages or formwork, or damage the faces of formwork.

Concrete shall not be allowed to accumulate in heaps to a total height, nor dropped onto horizontal surfaces from a height, greater than those described in 17.4.3 of BS 5975, unless the additional loading has been specifically taken into account in the design and is clearly indicated in the drawings or in contract specific Appendix 17/4.

Storage of materials on falsework, formwork or permanent formwork that produces concentrated or distributed pressures greater than 1.5 kN/m² shall not be permitted unless the additional loading has been specifically taken into account in the design and is clearly indicated in the drawings or in contract specific Appendix 17/4.

Concrete shall be thoroughly compacted by vibration during the operation of placing, and thoroughly worked around the reinforcement, tendons or duct formers, around embedded fixtures and into corners of the formwork, including permanent formwork, to form a solid mass free from voids. When vibrators are used to compact the concrete, vibration shall be applied continuously during the placing of each batch of concrete until the expulsion of air has practically ceased. A sufficient number of vibrators in serviceable condition shall be on site to ensure that spare equipment is always available in the event of breakdowns. Vibration shall not be applied by way of the reinforcement. Where vibrators of the immersion type are used, contact with reinforcement and inserts shall be avoided as far as is practicable.

The use of self-compacting concrete is not covered by this Specification.

Concrete shall not be subjected to disturbance between 4 hours and 24 hours after compaction except that re-compaction of the upper layers of deep lifts to prevent or anneal settlement cracking may be carried out. Whenever vibration has to be applied externally, the design of formwork and disposition and operation of vibrators shall ensure efficient compaction and the avoidance of surface blemishes.

There shall be no excess water on the top surface on completion of compaction.

Slipforming shall be performed with appropriate equipment using methods to ensure that the requirements of this Specification are met.

(12/14) **Removal of Formwork and Falsework**

- 4 (i) (12/14) General. Falsework and formwork shall be removed in a manner that does not damage the concrete, and at times to suit the requirements for its curing and to prevent restraint that may arise from elastic shortening, shrinkage or creep.
- (ii) (03/20) Timing of removal for cast in situ concrete. Where the concrete compressive strength is confirmed by tests on concrete cubes stored under conditions that simulate the field conditions, formwork supporting concrete in bending may be removed when the cylinder/cube strength is 12/15 N/mm² or the strength needed by the design, whichever is the greater. For ordinary structural concrete made with Portland cement (CEM I) or sulfate-resisting Portland cements (CEM I-SR 0 or CEM I-SR 3) of strength class 42.5 or above, in the absence of control cubes the period before removal shall be in accordance with the minimum periods given in Table 17/5.

TABLE 17/5: (03/20) Minimum Period Before Removing Falsework and Formwork (CEM I or SRPC Concrete)

	Minimum Period Before Removal		
	Surface temperature of concrete:		
	16°C	7°C	t°C (any temperature between 0°C and 25°C)
Vertical formwork to columns, walls and large beams	12 hours	18 hours	300/(t+10) hours
Soffit formwork to slabs	4 days	6 days	100/(t+10) days
Props to slabs	10 days	15 days	250/(t+10) days
Soffit formwork to Beams	9 days	14 days	230/(t+10) days
Props to beams	14 days	21 days	360/(t+10) days

Where surface temperatures of concrete fall outside or are likely to fall outside the above temperature ranges agreement shall be reached between the Contractor and Overseeing Organisation on appropriate removal times.

(12/14) **Curing of Concrete**

- 5 (i) (03/20) General. Curing Class 3 in accordance with Clause 8.5 of BS EN 13670 shall be used unless otherwise specified in contract specific Appendix 17/4. Additional special curing requirements may be given in contract specific Appendix 17/4.

Immediately after compaction and thereafter for the duration of applied curing, except where elevated temperature curing is used, concrete shall be protected against harmful effects of weather, including rain, rapid temperature changes, frost, and from drying out. The method of curing shall provide a suitable environment for the concrete to mature and prevent loss of moisture harmful to the quality of the concrete.

Where the Contractor proposes to use a curing liquid, compound or membrane on surfaces on which a waterproofing system is to be laid, it shall be completely removable. The Contractor shall keep records of all curing liquids, compounds and membranes and the areas of subsequent removal; such records shall be subsequently supplied to the Overseeing Organisation in accordance with the requirements of CG 302.

- (ii) (12/14) Accelerated curing. Elevated-temperature curing as described below may be used only for concrete made with Portland cement (CEM I) or sulfate-resisting Portland cements (CEM I-SR 0 or CEM I-SR 3).
- (a) The formwork may be generally heated to no more than 20°C prior to the placing of concrete.
 - (b) Once placing is complete the concrete shall be left for 4 hours without additional heating. The concrete temperature can then be raised at a maximum rate of 10°C per ½hour.
 - (c) The concrete temperature shall at no time exceed 70°C.
 - (d) The rate of subsequent cooling shall not exceed the rate of heating.
 - (e) Cubes shall be manufactured and cured under identical conditions to those to which the concrete is subjected.

The use of accelerated curing methods for concrete containing other types of cement or any admixture shall not be used.

(12/14) **Cold Weather Work**

- 6 (12/14) When concrete is placed at air temperatures below 2°C, the following requirements shall be met:
- (i) The aggregates and water used in the mix shall be free from snow, ice and frost.
 - (ii) The surface temperature of the concrete at the time of placing shall be at least 5°C. Where the concrete is made using CEM I or a CEM II/A cement, the concrete temperature shall not be more than 30°C. Where the concrete is made using a CEM II/B or a CEM III cement, or equivalent combination, the concrete temperature shall not be more than 35°C.
 - (iii) The surface temperature of the concrete shall be maintained at not less than 5°C until the concrete reaches a strength of 5 N/mm² as determined by tests on cubes that were cured under identical conditions to the structural concrete.
 - (iv) Before placing concrete, the formwork, reinforcement, prestressing steel and any surface with which the fresh concrete will be in contact shall be free from snow, ice and frost.
 - (v) Cement shall not be allowed to come into contact with water at a temperature greater than 60°C.

(12/14) **Hot Weather Work**

- 7 (12/14) During hot weather the Contractor shall ensure that the constituent materials of the concrete are sufficiently cool to prevent the concrete from stiffening in the interval between its discharge from the mixer and compaction in its final position.

Cement shall not be allowed to come into contact with water at a temperature greater than 60°C.

(12/14) **Precast Concrete Construction**

- 8 (i) (12/14) General
- Precast concrete elements to be used in the works shall comply with the following Product Standards as appropriate, which are relevant for highway structures:
- (a) Bridge deck elements shall comply with BS EN 15050.
 - (b) Foundation piles shall comply with BS EN 12794.
 - (c) Box culverts shall comply with BS EN 14844.
 - (d) Retaining wall elements shall comply with BS EN 15258.
 - (e) Masts and poles shall comply with BS EN 12483.

All precast concrete elements to be used in the works that fall within the scope of a Product Standard shall be supplied in accordance with that Standard. Precast elements that are outside the scope of a Product Standard shall conform to BS EN 13369 'Common rules for precast concrete products', unless otherwise described in contract specific Appendix 17/7.

Where minor site manufactured precast elements do not conform to any product standard or BS EN 13369, manufacture and construction operations shall comply with the provisions of BS EN 13670 and with this Specification.

For precast products, the manufacturing requirements as detailed in their relevant Product Standard or in BS EN 13369 shall be complied with; the construction operations from the reception at the site or, if site manufactured, from removal from the forms, shall comply with the provisions of BS EN 13670 and with this Specification. Where precast products are manufactured in temporary plants on site, the production shall be protected against adverse weather conditions and production control shall satisfy the requirements of Clause 6 of BS EN 13369.

(ii) (12/14) Manufacture of precast products

Precast products shall be suitable for their intended use and place of installation in the works. The relevant Product Standard for each precast product to be used shall be as identified in contract specific Appendix 17/7. Where there is no relevant Product Standard, reference to manufacture in accordance with BS EN 13369 shall be as quoted in contract specific Appendix 17/7.

Where a precast product is to be manufactured in accordance with a Product Standard, evidence of compliance with the harmonised part of the Product Standard with respect to product performance shall be demonstrated by CE marking and a Declaration of Performance where the declared performance for the essential characteristics given in Annex ZA of that Standard is equal to or greater than the performance level required for the intended use of the precast product.

The minimum set of information to be included with the CE marking and labelling in accordance with Annex ZA of the Product Standard shall be as required in contract specific Appendix 17/7.

(iii) (12/14) Manufacture of precast concrete elements not conforming to any Product Standard or to BS EN 13369

The Contractor shall give reasonable notice to the Overseeing Organisation in advance of the date of commencement of manufacture and casting of each type of element. A copy of all 28-day cube test results relating to the work, as scheduled in contract specific Appendix 1/5, shall be made available by the Contractor to the Overseeing Organisation in accordance with Clause 105.

For all prestressed elements, the Contractor shall provide to the Overseeing Organisation, not more than 7 days after the transfer of stress, a certificate showing the force and extension in the tendons after they were anchored, the strength and age of test cubes cast as described in sub-Clauses 1724.3 and 1724.4 and the minimum age in hours of the concrete at the time the stress was applied to the element.

For all prestressed pretensioned elements the length, cross-section dimensions and straightness of precast concrete shall be measured, as far as practicable, at 28 ± 2 days after casting. If earlier measurement is required, the manufacturer should allow for further shrinkage and creep between the time of measurement and 28 days, based on recorded experience.

All elements shall be indelibly marked to show the element mark as shown on the drawings, the weight of the element, the production line on which they were manufactured, the date on which the concrete was cast and, if they are of symmetrical section, the face that will be uppermost when the element is in its correct position in the works. The markings shall be so located that they are not exposed to view when the element is in its permanent position.

(iv) (03/20) Requirements for all precast elements (including precast products)

- (a) General. Where tests are to be carried out, no elements to which the tests relate shall be dispatched to the site until the tests have been satisfactorily completed. In the case where elements are manufactured in temporary plants on site, they shall not leave the designated production area until the tests have been satisfactorily completed.

Unless interface shear calculations in accordance with BS EN 1992-2 (Clause 6.2.5 of BS EN 1992-1-1) show that a non-prepared surface between concrete cast at different times is sufficient for structural purposes, the vibrated top surface of precast concrete elements which will subsequently receive in situ concrete shall be further prepared using one of the following methods and therefore considered as "Rough" in accordance to Clause 6.2.5 of BS EN 1992-1-1:

Class 1 surface preparation. The surface finish shall be in accordance with sub-Clause 1710.1.

Class 2 surface preparation. The hardened surface shall be jetted with air or water to remove laitance and all loose material and no further roughening shall then be carried out (rough as cast).

The surface classification and the method of preparation shall be shown on the drawings.

- (b) Handling. Elements shall be lifted or supported at points described in contract specific Appendix 17/7 and shall be handled and placed without impact. Additional constraints on the support, restraint and dynamic loading during handling or transport are described in contract specific Appendix 17/7. The Contractor shall incorporate, in the erection specification in accordance with BS EN 13670, the requirements of the lifting scheme for the precast concrete elements.
- (c) Storage. When elements are stored, they shall be firmly supported only at the points described in contract specific Appendix 17/7. Where elements are stacked several units high, packings shall be vertically above each other to prevent additional bending stresses in the elements, and the maximum height of the stack and any provision required to maintain stability shall be as described in contract specific Appendix 17/7. The accumulation of trapped water and deleterious matter in the units shall be prevented. Care shall be taken to avoid rust staining and efflorescence. Where disfigurement would be detrimental, packing pieces shall not discolour or otherwise permanently damage the elements.
- (d) Protection. At all stages of construction, precast concrete elements and other concrete associated therewith shall be properly protected to prevent damage to permanently exposed concrete surfaces, especially arrises and decorative features.
- (e) Placing and adjustment. An erection specification shall be prepared by the Contractor in accordance with BS EN 13670 and it shall be submitted for acceptance of the Overseeing Organisation at least 4 weeks prior to the delivery of the elements. The method of assembly and erection shall comply with any particular requirements in contract specific Appendix 17/7 and form part of the erection specification.
- (f) Requirements for placing and adjustment of composite slab bridges. In a composite slab bridge where precast beams are laid side by side with minimal gaps to form a deck, the difference in soffit level between adjacent units before the in situ concrete is placed shall nowhere exceed 5 mm for units up to 5 m in length or 10 mm for longer units, and the width of the deck soffit shall be within + 25 mm of that shown on the drawings; furthermore, the width of the gap between individual beams shall not exceed twice the nominal gap shown on the drawings. The alignment of transverse holes shall permit the reinforcement or prestressing tendons to be placed without distortion. In adjacent spans, the continuity of line of the outside beams shall be maintained.

Prior to placing permanent formwork, the rebates in precast concrete beams intended to receive the formwork shall be inspected to confirm they have been well formed and that any dressing-off is carried out before placing the formwork to ensure an even seating.

The in situ concrete in composite slab bridges shall be placed in such a sequence that the advancing edge of the freshly deposited concrete over the full width of the deck, between longitudinal construction joints, is approximately parallel to the deck supports. Precast beams shall be prevented from moving laterally during the placing of the in situ concrete.

- (g) Jointing and completion works. The composition and water/cement ratio of the in situ concrete or mortar used in any connection and in the packing of joints shall be in accordance with the erection specification. Levelling devices shall only be released or removed, in accordance with the erection specification when the structural connection is complete and has achieved sufficient strength.

Care shall be taken to ensure that the in situ material is thoroughly compacted.

When using proprietary jointing materials, the manufacturer's recommendations and any particular requirement in contract specific Appendix 17/7 for the application and methods shall be strictly followed to ensure full compatibility between the joint type and size and the sealing method.

(03/20) **Formation of Continuity Joints in Bridge Decks**

9 (i) (03/20) General

When concrete bridge decks are being widened, built in stages or reconstructed in stages with continuity joints, either by construction of a new part of the deck attached directly to the trafficked deck or by construction of a separate parallel deck followed by an in-fill strip as a second stage, the deck in the finished state shall be monolithic without any permanent joints or gaps.

(ii) Monitoring requirements

The differential deflection between the existing and the new part of the deck at the interface shall be monitored by the Contractor in accordance with contract specific requirements in Appendix 17/4 until the concrete achieves the specified characteristic strength or at least 7 days after placement, whichever is later, in the following situations:

- (a) when decks are widened by attaching a new part of the deck directly to the existing trafficked deck;
- (b) when decks are widened using the in-fill strip method and traffic is running less than 1m to the interface.

The limits on differential deflection between the new and existing parts of deck at the interface shall be as follows:

- (a) 6mm due to the weight of fresh concrete when the concrete for the new part of the deck is poured; and
- (b) 1mm due to traffic actions.

The vibration of the existing trafficked deck during the construction of the new part of the deck shall be monitored by the Contractor in accordance with the requirements in contract specific Appendix 17/4 until the concrete achieves the specified characteristic strength, or at least 7 days after placement, whichever is later. The measured peak particle velocity shall not exceed 5mm/s.

If the differential deflection or peak particle velocity measured on site are greater than the specified limits and no specific analysis is available to evaluate their effects on the structure, mitigation measures shall be implemented to reduce the differential deflection and peak particle velocity below their limits.

Results of the vibration and differential deflection monitoring shall be supplied to the Overseeing Organisation in accordance with the requirements of CG 302.

(iii) Existing concrete deck preparation

Existing concrete shall be removed in accordance with Clause 5707. Sufficient reinforcement shall be exposed in the removal to provide the full lap length in accordance with BS EN 1992-2.

The removal of existing concrete shall not damage the existing reinforcement.

Requirements for and restrictions on phased removal of concrete shall be as specified in contract specific Appendix 17/4.

The existing concrete substrate shall be prepared to concrete surface profile grade CSP6 or higher in accordance with the Guideline for Surface Preparation for the Repair of Deteriorated Concrete Resulting from Reinforcing Steel Corrosion, 310.1R-2008 published by the International Concrete Repair Institute. The surface of the exposed concrete substrate at the joint shall then be cleaned of all dust and grit using methods that themselves do not add contaminants to the exposed substrate.

The prepared substrate shall be continuously wetted with potable water for a minimum period of four hours. Any surface water remaining on the concrete breakout surface or reinforcement shall be removed prior to placement of the new concrete.

Placement of the new concrete shall commence before the substrate dries out, and not more than one hour after completion of wetting.

(iv) Requirements for concrete

The concrete used for the construction of the new parts of the deck shall comply with the requirements given in contract specific Appendix 17/1, with the slump limited to a maximum of 100mm.

(v) Requirements for reinforcement

Reinforcement shall be continuous across the continuity joint.

When the in-fill strip method is used, the reinforcement of the existing deck shall not extend beyond the in-fill strip to lap with new reinforcement.

The exposed existing steel reinforcement within the continuity joint shall be cleaned to achieve surface preparation standard SA2 ½ to BS EN ISO 8501-1. The exposed surface of the steel reinforcement shall be clean immediately prior to concreting and only light flash rusting on the reinforcement shall be permitted.

The reinforcement within continuity joints shall be securely tied at all bar intersections in accordance with Clause 1714.

(vi) Requirements for formwork

When the in-fill strip method is used, formwork for the new part of the deck shall be kept independent from the existing deck to ensure that traffic vibration is not transmitted at the first stage of parallel strip construction.

1711 (12/14) Concrete – Grouting and Duct Systems for Post-tensioned Tendons

(12/14) Planning, Trials and Basic Requirements

1 (12/14) Site operations, including duct installation, stressing and grouting, shall be carried out by organisations certificated in accordance with the requirements of the CARES product acceptance scheme for the Supply and Installation of Post-tensioning Systems in Concrete Structures (PT1), or an equivalent scheme. Post-tensioning systems shall be in accordance with Clause 7.2 of BS EN 13670. The system shall have the intended use category and shall meet any performance requirement stated in contract specific Appendix 17/6. The performance characteristics of the post-tensioning system shall be demonstrated by CE marking and a Declaration of Performance where the declared performance for the product characteristics is equal or greater than the performance level required for the intended use of the product.

Precast segmental construction using internal grouted tendon system is not permitted.

Grouts for protection of prestressing tendons shall be as required in contract specific Appendix 17/6 and defined in sub-Clause 1711.2. Grease and wax for post-tensioned unbonded tendons shall be as required in Clause 1725.

Unless otherwise agreed with the Overseeing Organisation, the Contractor shall undertake full-scale trials of the grouting operations as required in the Contract for duct installation, testing, concreting, grouting and any other associated requirements in accordance with the details described in contract specific Appendix 17/6. The trials are required to demonstrate that the grouting methods and procedures proposed by the Contractor shall ensure that grout fills the ducts and surrounds the prestressing steel.

The Contractor shall submit for acceptance of the Overseeing Organisation, a detailed method statement, at least 4 weeks prior to use in any trials or in the works, covering proposed materials, ducts, anchorage and vent arrangements, personnel, equipment, grouting procedures and quality control. The method statement shall also describe arrangements for storage and protection of materials (tendons etc.) on site, in the time between delivery and grouting.

Where full scale trials are required, these shall be carried out at least 56 days before the planned commencement of fixing ducts for prestressing for the permanent works unless specified otherwise in contract specific Appendix 17/6. The trials shall incorporate all relevant details of ducts, vents, duct supports, prestressing anchorages and couplers, prestressing strands, grout inlets and outlets. The tendons shall be sufficiently tensioned such that the strands within the duct take up a representative alignment. All systems, methods and materials are to be those proposed for the permanent works and shall have been submitted to the Overseeing Organisation as part of the detailed method statement required. After three days the Contractor shall carefully cut or core the trial section to expose cross

sections and longitudinal sections of the duct, anchorages and any other locations where required, or as further directed by the Overseeing Organisation, to demonstrate that the duct is satisfactorily grouted. A report shall be prepared by the Contractor giving full details of the trial, testing results and photographs of the exposed sections and submitted to the Overseeing Organisation.

Grouting of the ducts shall be shown to leave no void which has either a dimension greater than 5% of the duct diameter measured in the radial direction of the duct or which poses a risk to the protective system. The location of any voids with respect to grout vents and their adequate grouting and subsequent sealing, and the disposition of the steel tendons within the body of the grout shall be reported in writing by the Contractor to the Overseeing Organisation within 24 days. Prestressing for the permanent works shall not be permitted without the prior written acceptance of the grouting procedures by the Overseeing Organisation and formal acceptance of the results of the grouting trial.

Irrespective of whether the Contract requires full-scale grouting trials, the Contractor shall carry out a materials suitability assessment in accordance with sub-Clause 1711.2. Inspection and conformity of grouting works, including requirements prior, during and after grouting shall be in accordance with Section 9 of BS EN 446 for Execution Class 3.

(12/14) Grout Materials, Batching and Mixing

2 (12/14) Grouts shall comply with BS EN 447 and with the requirements in this sub-Clause and sub-Clause 1711.3.

The properties of the grout, made with the materials, and using the plant and personnel proposed for use on site, shall be assessed for suitability for the intended purpose by the Contractor in accordance with 6.1 of BS EN 446. This assessment shall be carried out sufficiently in advance of grouting operations to enable adjustments to be made in use of materials or plant or personnel. The assessment shall consist of the preparation of the grout, made with the materials, and using the plant and personnel proposed for use on site, and the testing of it in accordance with sub-Clause 1711.3. The preparation shall be carried out under representative conditions of temperature expected on site. If grouting operations are likely to cover different seasons, the assessment shall be carried out for the expected range of temperatures.

No departures from the sources of the materials and procedures approved as a result of satisfactory trials will be permitted without the written approval of the Overseeing Organisation.

When pre-bagged grouts are used, they shall be obtained from companies holding a valid CARES product acceptance scheme certificate for the production of pre-bagged grouts complying with the requirements of BS EN 445, BS EN 446 and BS EN 447 (PT10), or an equivalent scheme.

All bagged materials shall be weighed before use, unless clearly weight marked with stated tolerance.

(12/14) Admixtures

(12/14) Admixtures shall be used where required to achieve a low water/cement ratio and impart good fluidity, minimum bleed and volume stability or expansion to the grout to comply with sub-Clause 1711.3. For site batched grout, admixtures shall be added on site during the mixing process and used in accordance with the manufacturer's recommendations. For pre-bagged grout the admixtures shall form a pre-blended component.

Admixtures are divided into two types, expanding and non-expanding and they may be used to obtain the required grout performance. Admixtures used in combination shall be checked for compatibility by the Contractor, and reported to the Overseeing Organisation for acceptance.

Admixtures shall not contain substances in quantities that will adversely affect the grout or cause the grout to promote corrosion of the prestressing steel by rusting, pitting, stress corrosion or hydrogen embrittlement.

The admixture shall not segregate, shall be uniform in colour and the composition shall not change. Admixtures shall comply with BS EN 934-4; evidence of compliance with the harmonised part of BS EN 934-4 with respect to product performance shall be demonstrated by CE marking and a Declaration of Performance where the declared performance for the essential characteristics given in Annex ZA of that Standard is equal or greater than the performance level required for the intended use of the admixture.

The optimum dosage of any admixture shall be determined by trial mixes with the cement to be used in the grout. This dosage shall be expressed as percent by mass of the cement. It shall be within the range recommended by the supplier and shall not exceed 5% by mass of the cement. The method of measuring dosage and checking weights shall comply with this sub-Clause or as otherwise agreed with the Overseeing Organisation.

(12/14) **Batching and Mixing**

(12/14) All materials shall be batched by mass except the mixing water and liquid admixtures which may be batched by mass or by volume. Bagged materials shall be weighed before use, unless clearly weight marked with stated tolerance. The accuracy of batching shall be or have been (in case of pre-bagged materials):

± 2% for dry materials, cement and admixtures

± 1% for mixing water

of the quantities specified. The total amount of mixing water shall include the water content of liquid admixtures. Where proprietary pre-bagged grouts are used, they shall be mixed in accordance with the manufacturer's instructions.

Depending upon environmental or material influence (e.g. temperature, configuration of the tendon and properties of the materials used), the water/cement ratio shall be kept as low as possible having regard to the required plastic properties of the grout (see sub-Clause 1711.3). Actual water/cement ratios shall be recorded.

The material shall be mixed to produce a homogeneous grout and kept in slow continuous agitation until pumped into the duct. Unless manufacturers specify otherwise, water shall be added to the mixer first, followed by the dry materials which may be added as a whole or in part in sequence until the total quantities are added. The minimum mixing time determined from grouting trials shall be adhered to.

The temperature of freshly mixed grout shall be between 5°C and 30°C. The maximum temperature may be increased provided trials demonstrate that the grout meets the requirements of sub-Clause 1711.3.

(12/14) **Properties, Performance and Testing of Grout**

3 (12/14) The properties and performance requirements for grout shall be in accordance with Section 6 of BS EN 447. The requirements for suitability testing shall be in accordance with Section 6 of BS EN 446. Test methods are described in BS EN 445. Test requirements for grout during grouting shall be in accordance with Section 9 of BS EN 446 for Execution Class 3.

(12/14) **Duct Systems**

4 (12/14) The system of ducts, duct connectors, grouting connections, vents, vent connections, drains, transitions to anchorages and caps for anchors shall form a complete encapsulation for the tendons which is resistant to the ingress of air and water. Ducts shall be of plastic and shall not degrade during the expected life of the structure. The system shall be fully compatible with the prestressing anchorages, couplers and other details. Where ducts are non-conductive, metal parts of anchorages shall be electrically bonded to the adjacent reinforcement at each end of the tendon and electrical continuity of the structure over the length of the tendon shall be confirmed by testing. All ducts shall be kept free from standing water at all times and be thoroughly clean before grouting.

The following air pressure tests shall be carried out on site unless specified otherwise in contract specific Appendix 17/6.

(12/14) **Duct Assembly Verification Tests**

Each complete duct system including vents, anchorages, anchorage caps, and where appropriate couplers and their connections, shall be air-pressure tested before concreting. Testing to a pressure of 0.01 N/mm² unless otherwise specified in contract specific Appendix 17/6, shall demonstrate that the system is undamaged and has been correctly assembled. The testing shall demonstrate that a loss of pressure no greater than 10% occurs after 5 minutes.

The minimum manufactured wall thickness of ducting for internal tendons shall be 2 mm. The duct rigidity and type and spacing of fixings and supports shall be such as to maintain line, position and cross section shape during concreting. Local deformation of the duct at supports shall be avoided.

For external tendons the minimum wall thickness shall be 4 mm for durability, or such thicker wall as required to withstand grouting pressures of the particular duct configuration.

The Contractor shall provide evidence of testing to demonstrate the following requirements:

- (i) Wall thickness of ducts for tendons after tensioning of the tendons shall be not less than 1.5 mm unless specified otherwise in contract specific Appendix 17/6.
- (ii) For internal tendons the duct shall transmit full bond strength from the tendons to the surrounding concrete over a length no greater than 50-100 duct diameters or other such requirement as given in contract specific Appendix 17/6.

(12/14) Vents

Vents providing an air passage of at least 15 mm internal diameter shall be provided at the anchorages and in the troughs and crests and beyond each intermediate crest in the direction of flow of the grout at the point where the duct is one half diameter lower than the crest, (but no further than 1 m from the crest), unless otherwise described in contract specific Appendix 17/6. The maximum spacing of vents shall be 15 m unless specified otherwise in contract specific Appendix 17/6.

The vent diameter and spacing may be varied in full-scale trials demonstrating the suitability of alternatives. The vents shall be rigidly connected to the ducts, and shall be capable of being closed and re-opened. Holes in the ducts shall be at least the internal diameter of the vents and shall be formed before pressure testing.

For external tendons the arrangement and detailing of the vents at positions within deflectors/diaphragms shall be proven by detailed testing.

Vents on each duct shall be identified by labelling and shall be protected against damage at all times.

Vents at high points shall extend to a minimum of 500 mm above the highest point on the duct profile unless described otherwise in contract specific Appendix 17/6.

(12/14) Grouting Equipment

5 (12/14) Grouting equipment shall comply with the requirements of Section 7 of BS EN 446.

The equipment shall be capable of maintaining pressure on completely grouted ducts and shall be fitted with a valve that can be locked off without loss of pressure in the duct.

During the grouting operation the Contractor shall provide adequate flushing-out plant to facilitate complete removal of the grout in the event of a breakdown of the grouting equipment or other disruption before the grouting operation has been completed. Stand-by and emergency equipment shall be provided.

All equipment shall be kept free from build-up of adhering materials.

(12/14) Grouting Procedures

6 (12/14) Grouting procedures shall comply with the requirements of Section 8 of BS EN 446.

Grouting of the ducts shall be carried out within 14 days of installation of the tendon or as soon as is practicable thereafter, in which case additional measures shall be taken to avoid corrosion of the prestressing steel. The Overseeing Organisation's written agreement to commence grouting operations shall be obtained.

During grouting operations, once the fluidity of the grout flowing from the vents is the same as the grout being injected (to within the limits specified in BS EN 447, as per 8.4 of BS EN 446), 5 litres of grout at each vent, or such other requirement of contract specific Appendix 17/6, shall be vented into a clean receptacle and then discarded. The volume of all grout that is expelled shall be measured. The opening shall be firmly closed. All vents shall be closed in a similar manner one after another in the direction of the flow except that at intermediate crests the vents immediately downstream shall be closed before their associated crest vent. The injection tubes shall then be sealed off under pressure with a pressure of 0.5 N/mm² being maintained for at least one minute. Grout vents at high points shall be reopened immediately after 1 minute, while the grout is still fluid. Any escape of air, water or grout shall be recorded and reported immediately to the Overseeing Organisation. A further pumping of grout shall then be carried out to expel bleed water – and/or entrapped air. This shall be carried out with the vents open one at a time sequentially in the direction of grouting with a further 5 litres being released at each vent. In the event of disagreement over the quality of the vented grout, testing shall be undertaken immediately by the Contractor. Finally, when all outlets are closed the grout pressure shall be maintained for at least one minute to confirm there is no unintended loss due to leakage.

The filled ducts shall not be subjected to shock or vibration for at least 24 hours from the time of grouting.

When the grout has set, the grout vents shall be temporarily reopened. If voids are apparent on inspecting vents at end caps, the Overseeing Organisation may require all or some of the end caps to be removed to demonstrate that they are satisfactorily filled with grout. End caps which have been removed shall then be replaced and permanently sealed against ingress of contaminants, such sealing to be proved to the Overseeing Organisation.

If the method of demonstrating filling of the anchorage caps involves their removal, a photographic record shall be made by the Contractor. The record shall clearly identify the individual anchorages, and shall be included in the report to the Overseeing Organisation.

If, in the opinion of the Overseeing Organisation, there is doubt that the ducts or any part of the system are not satisfactorily filled with grout, the Overseeing Organisation may require investigations to be carried out.

The Contractor shall keep full records of grouting for each duct in accordance with the acceptance scheme requirements for the installation of post-tensioning systems. Copies of these records shall be supplied to the Overseeing Organisation within 24 hours of completing grouting to each duct.

On completion of grouting, grout vents shall be positively sealed and waterproofed by a means additional to but separate from the concrete waterproofing.

(12/14) Grouting During Cold or Hot Weather

7 (12/14) Requirements for grouting in cold or hot weather are given in 8.3 of BS EN 446.

When the ambient temperature is expected to fall below 5°C, accurate records shall be kept by the Contractor of the maximum and minimum air temperatures, and the temperatures of the structural elements adjacent to the ducts to be grouted.

When heating is considered appropriate, methods of heating shall be to the acceptance of the Overseeing Organisation. Ducts shall not be warmed with steam.

(12/14) Void Grouting

8 (12/14) Void grouting is the injection of grout into voids left in tendon ducts after the original grout has hardened and shall not be confused with regrouting, which means the reinjection of grout into ducts while the original grout is still fluid. Where the use of void grouting is proposed, it shall be subject to the approval of the Overseeing Organisation through its Departure from Standard processes.

1712 (12/14) Reinforcement – Materials

(12/14) Hot Rolled and Cold Worked Carbon Steel Bars

1 (12/14) All hot rolled and cold worked steel bars shall conform to BS EN 10080 and BS 4449 Grades B500B or B500C. Reinforcement shall be cut and bent in accordance with BS 8666. The bars shall be obtained from and cut and bent by organisations holding a valid CARES product acceptance scheme (or equivalent scheme) certificate of approval for the production and supply of steel for the reinforcement of concrete (see also sub-Clause 1712.8).

2 (12/14) Hot rolled and cold worked carbon steel bars shall conform to BS EN 10080 and BS 4449 except that no bar shall contain a flash weld.

(12/14) Steel Wire

3 (12/14) Steel wire shall only be used in precast concrete elements and shall be ribbed Grade 500 conforming to BS EN 10080 and BS 4482. Steel wire shall have a minimum nominal diameter of 8 mm and shall be obtained from organisations holding a valid CARES product acceptance scheme (or equivalent scheme) certificate of approval for the production and supply of steel wire (see also sub-Clause 1712.8).

(12/14) **Steel Fabric**

4 (12/14) Steel fabric reinforcement shall be Grades B500A, B500B or B500C conforming to BS EN 10080 and BS 4483. Steel fabric reinforcement shall be cut and bent in accordance with BS 8666. Steel fabric reinforcement shall have a minimum nominal bar size of 6 mm (8 mm for Grade B500A) and shall be obtained from organisations holding a valid CARES product acceptance scheme (or equivalent scheme) certificate of approval for the production and supply of steel fabric reinforcement (see also sub-Clause 1712.8). Steel fabric reinforcement shall be delivered to site in flat mats or pre-bent.

(12/14) **Stainless Steel Reinforcement**

5 (12/14) All stainless steel reinforcement shall conform to BS 6744 and shall be cut and bent in accordance with BS 8666 and shall be obtained from organisations holding valid CARES product acceptance scheme (or equivalent scheme) certificates of approval for the production and supply of stainless steel reinforcement (see also sub-Clause 1712.8).

6 (12/14) Stainless steel reinforcement shall be ribbed Grade 500 conforming to BS 6744 and the additional properties described in contract specific Appendix 17/4.

(12/14) **Bond Strength**

7 (12/14) For hot rolled and cold worked carbon steel bars, and for steel fabric reinforcement, the bond property requirements of BS 4449 shall be complied with based on the surface geometry requirements of that standard. For steel wire, the bond property requirements of BS 4482 shall be complied with based on the surface geometry requirements of that standard.

(12/14) **Traceability and Identification of Reinforcement**

8 (12/14) Any product acceptance scheme shall ensure that materials used in reinforcing bars are traceable from their initial production casts, through rolling and other treatments to delivery on site of straight bar or cut and bent steel. The marking system on reinforcement shall be secure, clear and unambiguous. Marking must also identify the grade of a reinforcement bar both in terms of strength and ductility. Materials complying with the requirements given in sub-Clauses 1712.1 to 6 and supplied in accordance with the CARES product acceptance scheme or equivalent scheme shall be deemed to meet the requirements for traceability and identification of materials described above.

1713 (12/14) Carbon Steel Reinforcement and Stainless Steel Reinforcement – Bar Schedule Dimensions – Cutting and Bending

1 (12/14) The bar schedules are based on the dimensions of the concrete and the nominal cover to the reinforcement shown on the drawings. The reinforcement shall be cut and bent within the tolerances given in BS 8666 but this shall not relieve the Contractor of his responsibility for the correct fit of the reinforcement and the achievement of the required cover as described in Clause 1714. The mandrel diameter for bending bars shall comply with Clause 8.3 of BS EN 1992-1-1.

Bending of reinforcement at temperatures below 5°C or in excess of 100°C shall not be carried out.

Re-bending of carbon steel bars and fabric reinforcement shall not be permitted.

Re-bending of stainless steel reinforcement bars shall not be permitted.

Site storage of reinforcement shall ensure that it is clear of the ground and covered with a waterproof sheeting or fixed cover, in order to reduce contamination and excess corrosion prior to placement.

1714 (12/14) Reinforcement – Fixing

1 (03/20) Reinforcement shall be secured against displacement and tied together in accordance with BS 7973-2. The positioning of reinforcement shall be within the tolerances given in sub-Clause 1728.3.

Bars in inner layers shall be located as shown on the drawings.

Welding of carbon steel reinforcing bars for fixing purposes shall be in accordance with Clause 1717. Welding of stainless steel reinforcement bars shall not be permitted.

Cover shall be achieved by using spacers and chairs which meet the performance requirements of BS 7973-1. They shall be designed so that they will not overturn or be displaced when the concrete is placed. Reinforcement spacers and chairs shall be fixed in accordance with BS 7973-2.

Spacer blocks shall be factory produced proprietary products. Site produced or other non-proprietary spacers shall not be used.

Wire cast in spacer block for the purpose of tying it to the reinforcement shall be as described below. Projecting ends of ties or clips shall not encroach into the concrete cover.

Tying wires shall be 1.2 mm diameter stainless steel wire for bridge decks and exposed surfaces and any other locations as described in contract specific Appendix 17/4. In other areas 1.6 mm soft annealed iron wire may be used. Stainless steel tying wire shall be used when tying stainless steel reinforcement.

The Contractor shall provide access and carry out a cover measurement survey of all reinforced concrete surfaces within the 24-hour period following the removal of formwork. The cover measurement survey shall be carried out on a 500 mm grid over the whole structure. A record of the survey shall be kept and subsequently supplied to the Overseeing Organisation in accordance with the requirements of CG 302.

1715 (12/14) Reinforcement – Surface Condition

1 (12/14) Immediately before concrete is placed around it, reinforcement shall be free from mud, oil, paint, retarder, release agent, loose rust, loose mill scale, snow, ice, grease or any other substance that can be shown to have an adverse chemical effect on the steel or concrete, or to reduce the bond between the steel and the concrete.

1716 (12/14) Reinforcement – Laps and Joints

1 (12/14) Laps and joints shall be made only where shown on the drawings, except in the case where additional laps or splice bars are required and the Overseeing Organisation's approval has been obtained.

2 (12/14) Where reinforcing bars are required to be coupled the coupling system shall have a current British Board of Agrément Roads and Bridges Certificate or CARES product acceptance scheme Certificate of Product Assessment TA1-A for use with Highway Structures or equivalent scheme and shall be sourced, applied and processed from organisations holding relevant valid CARES product acceptance scheme (or equivalent scheme) certificate of approval. Couplers shall comply with cover requirements of sub-Clause 1714.1.

1717 (12/14) Reinforcement – Welding

(12/14) General

1 (12/14) Welded reinforcement, other than steel fabric reinforcement, shall not be incorporated in the permanent works unless permitted in contract specific Appendix 17/4. When required, welding of reinforcing bars shall comply with the requirements of Clause 3.2.5 of BS EN 1992-1-1, shall be carried out in accordance with BS EN ISO 17660 and be subject to the demonstration of the satisfactory performance of trial joints. The Contractor shall demonstrate that at each location the fatigue life, durability and other properties of the member are not adversely affected by the proposal.

Site welding of stainless steel reinforcement bars shall not be permitted.

(12/14) Strength of Structural Welded Joints

2 (12/14) The strength of all structural welded joints shall be assessed following tests on trial joints to establish the minimum specified mechanical properties of the joint. Tests shall be carried out by an independent testing body appropriately accredited as described in Clause 105.

1718 (12/14) Prestressing Tendons – Materials

(12/14) Steel Wires and Strands

1 (12/14) Steel wires and strands shall comply with BS 5896 and shall be obtained from an organisation holding a valid CARES product acceptance scheme certificate of approval for the production of prestressing steel wires and strands (PT6-PT8), or equivalent scheme.

(12/14) Cold Worked High Tensile Alloy Bar

2 (12/14) Cold worked high tensile alloy steel bars for prestressed concrete shall comply with BS 4486 and shall be obtained from an organisation holding a valid CARES product acceptance scheme certificate of approval for the production of prestressing steel bars (PT7), or equivalent scheme.

(12/14) Sampling and Testing

3 (12/14) When it is proposed to use other than the lowest strength diameter wire or strand complying with BS 5896, the following shall apply:

- (i) A sample shall be taken from each reel of material proposed for use in the works.
- (ii) A reel shall only be accepted if both the breaking load and the 0.1% proof load of the sample exceeds the specified characteristic loads given in BS 5896.

4 (12/14) Where scheduled in contract specific Appendix 1/5, the Contractor shall arrange for samples of the steel intended for use in the permanent works to be tested at a testing laboratory appropriately accredited as described in Clause 105.

5 (12/14) Testing of prestressing steel bar, wire and strand shall be performed in accordance with BS EN ISO 15630-3.

1719 (12/14) Prestressing Tendons – Handling and Storage

1 (12/14) Prestressing tendons shall not be mechanically damaged, work hardened or heated during handling. All prestressing tendons shall be stored clear of the ground and protected from the weather, from splashes from any other materials, and from splashes from the cutting operation of an oxy-acetylene torch, or arc-welding processes in the vicinity.

In no circumstances shall prestressing tendons after manufacture be subjected to any welding operation, or heat treatment or metallic coating such as galvanizing. This does not preclude cutting as described in Clause 1722.

1720 (12/14) Prestressing Tendons – Surface Condition

1 (12/14) Prestressing tendons and internal and external surfaces of sheaths or ducts shall be clean and free from pitting at the time of incorporation in the works. Slight surface rusting is generally acceptable, unless in environmentally severe sites (marine or industrial).

1721 (12/14) Prestressing Tendons – Straightness

(12/14) Wire

1 Low relaxation and normal relaxation wire shall be in coils of sufficiently large diameter to ensure that the wire pays off straight, except that in cases where straight as-drawn wire is not essential, wire in small-diameter coils (corresponding to the diameter of the blocks in the drawing machine) may be used.

(12/14) **Strand**

2 Prestressing strand, however manufactured, shall be in coils of sufficiently large diameter to ensure that the strand pays off straight.

(12/14) **Bars**

3 (12/14) Prestressing bars as delivered shall be straight. Any small adjustments for straightness that are necessary on site shall be made by hand. Bars bent in the threaded portion shall be rejected. Any straightening of bars shall be carried out cold but at a temperature of not less than 5°C. Any necessary warming shall be by means of steam or hot water.

1722 (12/14) Prestressing Tendons – Cutting

1 (12/14) All cutting of wire, strand or bar shall be carried out after gradual release of the tension in the tendons to be cut. Cutting shall be executed using either:

- (i) a high-speed abrasive cutting wheel, friction saw or equivalent mechanical method at not less than one tendon diameter from the anchor; or
- (ii) an oxy-acetylene cutting flame, using excess oxygen to ensure a cutting rather than a melting action, not less than 75 mm from the anchor. The temperature of the tendon adjacent to the anchor shall not be greater than 200°C. Neither the flame nor splashes from the cutting operations shall come into contact with the anchorages or uncut tendons.

1723 (12/14) Prestressing Tendons – Positioning of Tendons, Sheaths and Duct Formers

1 (12/14) Tendons, sheaths and duct formers shall be accurately located and maintained in position both vertically and horizontally as shown on the drawings. The position shall be within the tolerances given in sub-Clause 1728.3.

Where tendons are described in the contract as debonded from the concrete they shall be covered with suitable sleeves. The ends of the sleeves shall be taped to the tendon to prevent the ingress of grout.

Joints in sheaths shall be securely taped to prevent penetration of the duct by concrete or laitance, and ends of ducts shall be sealed and protected after the stressing and grouting operations. Joints in adjacent sheaths shall be spaced at least 300 mm apart.

1724 (12/14) Prestressing Tendons – Tensioning

(12/14) **General**

1 (12/14) All wires, strands or bars stressed in one operation shall be taken, where possible, from the same parcel. Each cable shall be tagged with its number from which the coil numbers of the steel used can be identified. Cables shall not be kinked or twisted. Individual wires and strands for which extensions are to be measured shall be readily identifiable at each end of the member. No strand that has become unravelled shall be used. Strands of the same diameter but with different strength grades must not be used in the same beam.

(12/14) **Tensioning Apparatus**

2 (12/14) The tensioning apparatus shall meet the following general requirements:

- (i) The means of attachment of the tendon to the jack or tensioning device shall be safe and secure.
- (ii) Where two or more wires or strands are stressed simultaneously, they shall be approximately of equal length between anchorage points at the datum of load and extension measurement. The degree of variation shall be small compared with the expected extension.
- (iii) The tensioning apparatus shall be such that a controlled total force is imposed gradually and no dangerous secondary stresses are induced in the tendons, anchorage or concrete.

- (iv) The force in the tendons during tensioning shall be measured by direct-reading load cells or obtained indirectly from gauges fitted in the hydraulic system to determine the pressure in the jacks. Facilities shall be provided for the measurement of the extension of the tendon and of any movement of the tendon in the gripping devices. The load measuring device shall be calibrated to an accuracy within $\pm 2\%$ and checked at frequent intervals. The valid calibration records shall be available on site before tensioning starts. Elongation of the tendon shall be measured to an accuracy within 2% or 2 mm, whichever is the greater.
- (v) The tensioning equipment shall be calibrated before the tensioning operation and subsequently at frequent intervals.

(12/14) **Pretensioning**

3 (12/14) Where pretensioning methods are used, the tension shall be fully maintained by some positive means during the period between tensioning and transfer. The transfer of stress shall take place slowly to minimize shock.

- (i) Straight tendons. In the long-line method of pretensioning, sufficient locator plates shall be distributed throughout the length of the bed to ensure that the wires or strands are maintained in their proper position during concreting. Where a number of units are made in line, they shall be free to slide in the direction of their length and thus permit transfer of the prestressing force to the concrete along the whole line. In the individual mould system, the moulds shall be sufficiently rigid to provide the reaction to the prestressing force without distortion.
- (ii) Deflected tendons. Where possible, the mechanisms for holding down or holding up tendons shall ensure that the part in contact with the tendon is free to move in the line of the tendon so that frictional losses are nullified. If, however, a system is used that develops a frictional force, this force shall be determined by test and due allowance made. For single tendons the deflector in contact with the tendon shall have a radius of not less than 5 times the tendon diameter for wire or 10 times the tendon diameter for strand, and the total angle of deflection shall not exceed 15° . The transfer of the prestressing force to the concrete shall be effected in conjunction with the release of hold-down and hold-up forces.

Unless otherwise described in contract specific Appendix 17/4, concrete shall not be stressed until it has reached at least the age at which 2 test results from specimens taken from it (each obtained from the average of two test cubes made from one concrete sample) attain the specified characteristic compressive strength at the time when the concrete is subjected to the prestressing force. Testing shall be as described in Annex B.5 of BS 8500-1 and Annex B of BS EN 206-1. The samples shall be taken as described in BS EN 12350-1 and the test cubes shall be made and tested as described in BS EN 12390-2 and BS EN 12390-3 respectively. They shall be cured in similar conditions to the concrete to which they relate. The Contractor shall cast and test sufficient cubes to demonstrate that the required strength of the concrete at transfer has been reached.

(12/14) **Post-tensioning**

4 (12/14) In addition to the present Clause, the installation of post-tensioning systems shall comply with the requirements of Clause 1711.

- (i) Arrangement of tendons. Where wires, strands or bars in a tendon are not stressed simultaneously, the use of spacers shall be in accordance with the recommendations of the system manufacturer.
- (ii) Anchorages. Prestressing anchorages for post-tensioning systems shall be in accordance with Clause 7.2 of BS EN 13670 and shall be supplied by organisation certificated with the CARES product acceptance scheme for the Production and Supply of Prestressing Anchorages for Post-tensioning Systems (PT3), or an equivalent scheme. Anchorages shall comply with the minimum performance requirements of BS EN 13391. For each anchorage system used in the works, the characteristic value for anchorage efficiency shall be not less than 95%. Proprietary anchorages shall be handled and used strictly in accordance with the manufacturer's instructions and recommendations.
- (iii) Deflected tendons. The deflector in contact with the tendon shall have a radius of not less than 50 times the diameter of the tendon, and the total angle of deflection shall not exceed 15° .

- (iv) Tensioning procedure. Before tensioning, the Contractor shall demonstrate that all tendons are free to move in the ducts unless the geometry of the ducts makes this impracticable. Tensioning shall be carried out in such a manner that the stress in the tendons increases at a gradual and steady rate. Tensioning shall not be carried out at a temperature below 0°C.

Unless otherwise described in contract specific Appendix 17/4, concrete shall not be stressed until it has reached at least the age at which 2 test results from specimens taken from it (each obtained from the average of two test cubes made from one concrete sample) attain the specified characteristic compressive strength at the time when the concrete is subjected to the prestressing force. Testing shall be as described in Annex B.5 of BS 8500-1 and Annex B of BS EN 206-1. The samples shall be taken as described in BS EN 12350-1 and the test cubes shall be made and tested as described in BS EN 12390-2 and BS EN 12390-3 respectively. They shall be cured in similar conditions to the concrete to which they relate. The Contractor shall cast and test sufficient cubes to demonstrate that the required strength of the concrete at transfer has been reached.

The Contractor shall ensure that those carrying out the stressing are provided with particulars of the required tendon loads, order of stressing and extensions. Allowance shall be made during stressing for the friction in the jack and in the anchorage, although the former is not necessary when using load cells, and for draw-in of the tendon during anchoring.

Stressing shall continue until the required extension and tendon load are reached. The extension shall allow for any draw-in of the tendon occurring at a non-jacking end, but measurement shall not commence until any slack in the tendon has been taken up.

Immediately after anchoring, the forces in the prestressing tendons shall not exceed 70% of their characteristic strength. During stressing the value may exceed 70% of their characteristic strength but shall not exceed 80%.

After the tendons have been anchored, the force exerted by the tensioning apparatus shall be decreased gradually and steadily so as to avoid shock to the tendon or the anchorage. Full records shall be kept of all tensioning operations, including the measured extensions, pressure-gauge or load-cell readings, and the amount of draw-in at each anchorage. When requested by the Overseeing Organisation, copies of these records shall be provided within 24 hours of each tensioning operation.

Tendons shall not be cut within 3 days of their being grouted; however, in the case of deviation from the planned performance during tensioning, cutting of the tendons, grouting and work which can impair the re-tensioning shall not take place until the causes have been investigated and revised tensioning report has been approved.

1725 (12/14) Prestressing Tendons – Protection and Bond

1 (12/14) The prestressing tendons shall be protected in their permanent positions from both mechanical damage and corrosion as described in contract specific Appendix 17/4.

Grout and grouting operations for filling ducts and anchorages of post-tensioned bonded tendons (internal or external) shall be in accordance with Clause 1711.

Grease and wax for the protection of sheaths and anchorages of unbonded tendons shall be in accordance with Clauses 7.2 and 7.6 of BS EN 13670.

Vents, grout inlets and outlets and anchorages shall be sealed to assure corrosion protection equivalent to that provided along the tendon. Anchorage zones shall be protected from drainage water.

Unbonded tendons shall be sealed throughout their length against penetration of moisture.

1726 (12/14) Stainless Steel Dowels – Materials

1 (12/14) Dowels shall be made from Steel Designation 1.4429 or 1.4436 and Grade 200 or 500 steel bars complying with BS 6744.

1727 (12/14) Inspection and Testing of Structures and Components

(12/14) General

1 (12/14) Inspection and testing of structures and components shall be in accordance with BS EN 13670 for the designated Execution Class (see Clause 1701) and carried out as described in contract specific Appendix 17/4 and as scheduled in contract specific Appendices 1/5 and/or 1/6. The documentation of inspection shall be in accordance with BS EN 13670 and this Specification.

1728 (12/14) Geometrical Tolerances

(12/14) General

1 (12/14) The tolerances given in Clauses 10.4 to 10.6 of BS EN 13670 and in its Annex have been derived specifically for buildings and shall not be applied to highway works. Instead, the requirements of this Clause apply. The tolerances given in this Clause are not cumulative. Further project specific tolerances shall be as described in contract specific Appendix 17/4 and on the drawings.

(12/14) Reference System

2 (12/14) The location of the reference grids or primary lines and levels for the overall positioning of the works shall be agreed between the Overseeing Organisation and the Contractor before the works are set out.

(12/14) Sections

3 (12/14) The dimensions of cross-section, the cover and position of reinforcement and prestressing tendons shall not deviate more than the values given in Figure 17/2. With the exception of case (d) in Figure 17/2, these values do not apply to precast concrete elements, which shall conform to the provisions for geometrical tolerances in BS EN 13369 and/or to the relevant Product Standard as appropriate (see sub-Clause 17/10.8).

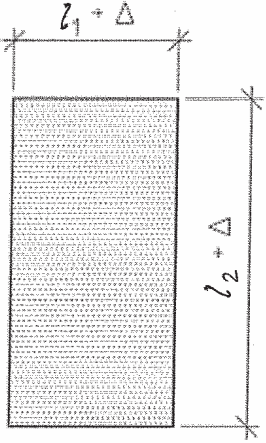
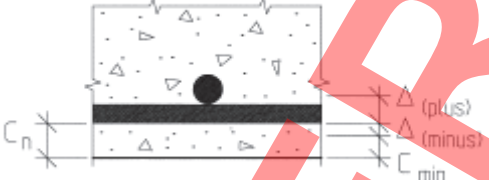
No.	Type of deviation	Description	Permitted deviation Δ
a	Cross-sectional dimensions 	l_1 = Length of cross-sectional dimension Applicable to beams, slabs and columns For $l_1 < 150$ mm $l_1 = 400$ mm $l_1 \geq 2500$ mm with linear interpolation for intermediate values	± 5 mm ± 10 mm ± 30 mm
b	Location of ordinary reinforcement Cross Section 	$h \leq 150$ mm, $h = 400$ mm, $h \geq 2500$ mm, with linear interpolation for intermediate values	$\Delta_{(plus)} = + 5$ mm $\Delta_{(plus)} = + 10$ mm $\Delta_{(plus)} = + 20$ mm
	c_{min} = required minimum cover c_n = nominal cover = $c_{min} + \Delta_{(minus)} $ c = actual cover Δ = permitted deviation from c_n h = height of cross-section	All values of h	$\Delta_{(minus)} = \Delta c_{dev}^a$
	Requirement: $c_n + \Delta_{(plus)} > c > c_n - \Delta_{(minus)} $ a) Δc_{dev} can be taken equal to 10 mm, as recommended in the UK National Annex to BS EN 1992-1-1 and BS EN 1992-2. See NG 1704.4 and Table NG 17/1 for guidance on cover. NOTE: Permitted plus-deviations for cover to reinforcement for foundations and concrete members in foundations may be increased by 15 mm. The given minus-deviations apply.		

(03/20) Figure 17/2 – Permitted Sectional Deviations

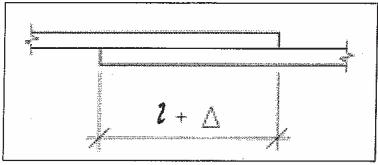
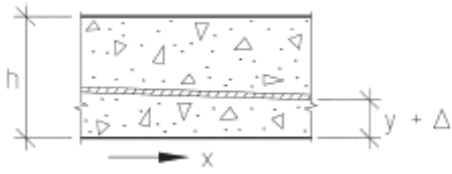
c	<p>Lap-joints</p> 	$l = \text{Lap length}$	$- 0,06 l$
d	<p>Location of prestressing duct Longitudinal section</p> 	$y = \text{Intended distance to centreline of duct in plan or elevation}$	$\pm 5 \text{ mm}$

(03/20) **Figure 17/2 – Permitted Sectional Deviations (Continued)**

(12/14) **Permitted Deviations at Support Bearings**

4 (12/14) The position of bearings at supports shall not deviate more than the values given in Figure 17/3.

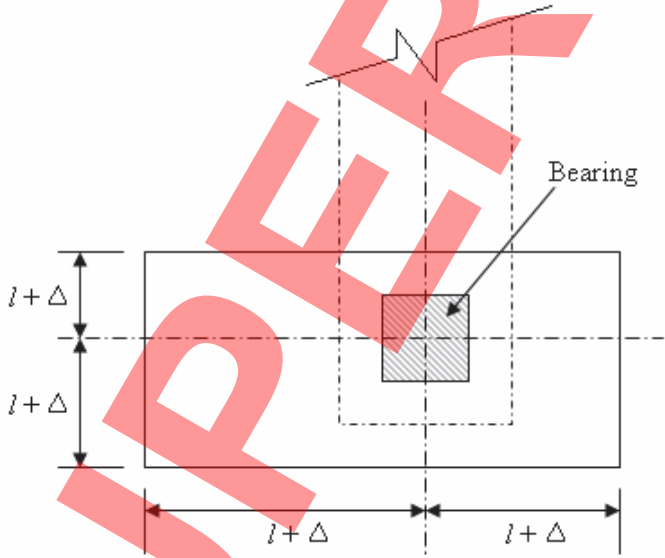
No.	Type of deviation	Description	Permitted deviation Δ
a	<p>Position of bearing axis of support when structural bearings are used</p> 	$l = \text{Intended distance from all edges}$	<p>The larger value, taken with the negative sign, between</p> <ul style="list-style-type: none"> $- l/50$ and $- 5 \text{ mm}$ and not greater than $- 15 \text{ mm}$ but for columns not greater than the larger value, taken with the negative sign, between $- 15 \text{ mm}$ and $- h/600$ <p>where $h = \text{free height of column}$</p>

(03/20) **Figure 17/3 – Permitted Deviations at Support Bearings**

(12/14) **Permitted Deviations for Columns and Walls**

5 (12/14) The dimensions of columns and walls shall not deviate more than the values given in Figure 17/4.

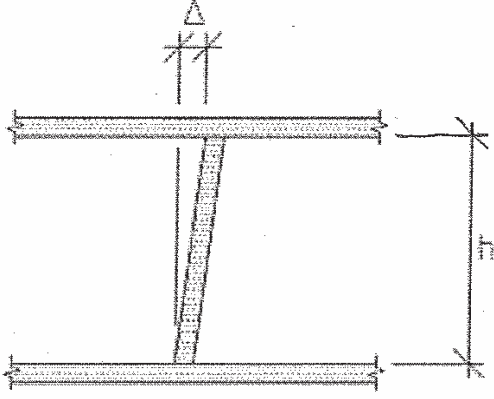
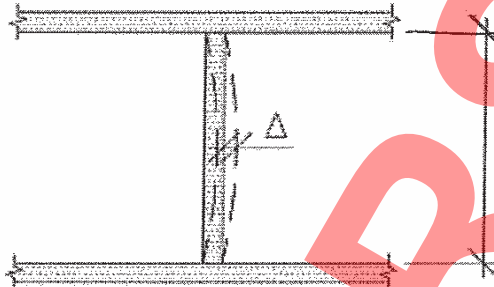
No.	Type of deviation	Description	Permitted deviation Δ
a	Inclination of a column or wall 	h = free height	The larger of h/600 or 15 mm
b	Curvature of a column or wall 	h = free height	The larger of h/600 or 15 mm

(03/20) **Figure 17/4 – Permitted Deviations for Columns and Walls**

1729 (03/20) Post-Installed Anchors and Reinforcing Bar Connections

(03/20) **General**

1 (03/20) Post-installed anchors and systems for post-installed reinforcement bar connections shall have a European Technical Assessment (ETA) issued under regulation (EU) No. 305/2011 suitable for their intended use and application, and shall comply with the requirement in contract specific Appendix 17/8.

2 (03/20) The Contractor shall design the post installed anchors and/or reinforcing bars connections stated in contract specific Appendix 1/10.

3 (03/20) Post-installed anchors and reinforcing bars connections shall be designed in accordance with the design method in the relevant ETA, the requirements in CD 372 and requirements listed in contract specific Appendices 1/10 and 17/8.

(03/20) **Installation**

4 (03/20) Post installed anchors and systems for post-installed reinforcement bar connections shall be installed in accordance with their ETA and the manufacturers' recommended methods.

- 5 (03/20) The position of post-installed anchors and reinforcing bar connections in the permanent works shall be as stated in contract specific Appendix 17/8.
- 6 (03/20) The installation shall comply with the following:
- The installation work shall not cause damage to the concrete base material or any waterproofing around the drill holes.
 - Reinforcement within the concrete base material shall not be struck, damaged or cut unless permitted in contract specific Appendix 17/8.
 - Before and after drilling holes, the Contractor shall carry out a survey of the surrounding existing concrete, to include all concrete within 300mm of the drilling location. Defects such as fractures, cracks and voids shall be brought to the attention of the Overseeing Organisation.
 - For bonded anchors and reinforcing bar connections, the Contractor shall ensure that the cementitious grout or resin fills the hole entirely without air voids following insertion of the anchor or reinforcing bar and that the anchor or reinforcing bar is fully surrounded by the grout or resin. Excess grout or resin shall be removed immediately.
 - The anchors or reinforcing bars shall be free of rust and contamination that may affect the anchorage bond.
 - Dissimilar metals shall be isolated.

(03/20) **Reinforcing Bars for Reinforcing Bar Connections**

- 7 (03/20) The material of the reinforcing bars shall be carbon steel conforming to BS 4449 or stainless steel conforming to BS 6744.
- 8 (03/20) The stainless steel grade shall be as stated in contract specific Appendix 17/8.

(03/20) **Testing**

- 9 (03/20) Axial load proof tests shall be carried out on the fixings in accordance with the procedures of the Construction Fixings Association (CFA) guidance note 'Procedure for site testing construction fixings'.
- 10 (03/20) The testing shall be carried out by a person holding suitable, current qualifications. The qualifications shall include assessment by a third party and shall include testing of the type of anchor(s) or post-installed reinforcing bar connection(s) to be used in the works. Evidence of the qualifications shall be submitted to the Overseeing Organisation prior to testing being undertaken. An example of suitable qualifications would be those assessed by CFA.
- 11 (03/20) The magnitude of the proof load tests shall be determined in accordance with the requirements in contract specific Appendix 17/8. Testing shall be undertaken in accordance with the details stated in contract specific Appendices 1/5 and 17/8. The number of fixings to be tested shall be a minimum of 3 for each different installation team.
- 12 (03/20) The total movement of the anchor/reinforcing bar, less the calculated elongation of the anchor/reinforcing bar during the test, based on the length of the anchor/reinforcing bar between the concrete surface and the point of load application, shall not exceed 5% of the nominal diameter of the anchor/reinforcing bar.
- 13 (03/20) Any evidence of slip during loading up to the test load, as demonstrated by a significant change in the slope of the load/extension curve, shall constitute a failure.
- 14 (03/20) If the failure load of any of the tested post-installed anchor or reinforcing bar connection is less than the required test load, the testing frequency shall be increased by a factor of 2 and remedial actions shall be proposed for agreement by the Overseeing Organisation.
- 15 (03/20) A test report, prepared in accordance with CFA guidance note 'Procedure for site testing construction fixings', shall be supplied to the Overseeing Organisation in accordance with the requirements of CG 302 within 14 days of the testing.

(03/20) **Reuse of Anchors**

16 (03/20) Permanent anchors shall not be removed and reused elsewhere.

(03/20) **Records**

17 (03/20) Records from the design of permanent anchors or reinforcing bar connections, as set out in CD 372, shall be submitted to the Overseeing Organisation upon completion of the works in accordance with the requirements of CG 302.

SUPERSEDED