

# Design Manual for Roads and Bridges



Highway Structures & Bridges  
Design

## CD 352

# Design of road tunnels

(formerly BD 78/99)

Version 0.0.1

### Summary

This document describes the procedures necessary for the design and refurbishment of all tunnels on the motorway and all-purpose trunk road network.

### National Variation

This document has associated National Application Annexes providing alternative or supplementary content to that given in the core document, which is relevant to specific Overseeing Organisations. National Application Annexes are adjoined at the end of this document.

### Feedback and Enquiries

Users of this document are encouraged to raise any enquiries and/or provide feedback on the content and usage of this document to the dedicated National Highways team. The online feedback form for all enquiries and feedback can be accessed at: [www.standardsforhighways.co.uk/feedback](https://www.standardsforhighways.co.uk/feedback).

**This is a controlled document.**

<b>Release notes</b>	<b>6</b>
<b>Foreword</b>	<b>7</b>
Publishing information . . . . .	7
Contractual and legal considerations . . . . .	7
<b>Introduction</b>	<b>8</b>
Background . . . . .	8
Section 2: . . . . .	8
Section 3: . . . . .	8
Section 4: . . . . .	8
Section 5: . . . . .	8
Section 6: . . . . .	8
Section 7: . . . . .	8
Section 8: . . . . .	9
Section 9: . . . . .	9
Section 10: . . . . .	9
Section 11: . . . . .	9
Section 12: . . . . .	9
Assumptions made . . . . .	9
Mutual Recognition . . . . .	9
<b>Abbreviations</b>	<b>10</b>
<b>Terms and definitions</b>	<b>17</b>
<b>1. Scope</b>	<b>19</b>
Aspects covered . . . . .	19
Implementation . . . . .	19
Use of GG 101 . . . . .	19
<b>2. Planning, safety and general design</b>	<b>20</b>
General . . . . .	20
General design . . . . .	21
Technical approval . . . . .	22
Regulatory reform (fire safety) order (RR(FS)O) . . . . .	22
The Equality Act . . . . .	22
Building information modelling . . . . .	22
Tunnel operation . . . . .	22
Tunnel design and safety consultation group (TDSCG) . . . . .	23
Safety . . . . .	24
Transportation of dangerous goods . . . . .	28
Power supplies . . . . .	29
Traffic management . . . . .	29
Restrictions on tunnel use . . . . .	29
Cladding . . . . .	30
Selection of appropriate tunnel type . . . . .	30
<b>3. Road tunnel safety</b>	<b>35</b>
General . . . . .	35
Tunnel safety facility provision . . . . .	35
Typical safety facilities, tunnel layout and structural features . . . . .	38
General . . . . .	38
Emergency panels . . . . .	38
Emergency stopping lanes . . . . .	39
Escape routes . . . . .	39
Vehicle crossovers . . . . .	39
Turning bays . . . . .	39

Emergency services parking . . . . .	39
Drainage . . . . .	39
Detection of incidents . . . . .	40
Tunnel communications and emergency facilities . . . . .	40
Communications . . . . .	40
Traffic controls . . . . .	40
Tunnel emergency systems availability . . . . .	41
Fire alarm & smoke control . . . . .	41
Tunnel lighting . . . . .	41
Mainspower failure and emergency lighting . . . . .	41
Tunnel signs and signals . . . . .	41
Value engineering . . . . .	41
<b>4. Geometric design</b>	<b>43</b>
General . . . . .	43
Tunnel cross section . . . . .	44
Maintained headroom . . . . .	45
Traffic lane width . . . . .	46
Vehicle restraint systems . . . . .	46
<b>5. Ventilation requirements</b>	<b>47</b>
General . . . . .	47
Natural tunnel ventilation . . . . .	47
Mechanical tunnel ventilation . . . . .	47
Smoke control panels . . . . .	49
Enclosed escape routes and cross-passages . . . . .	49
Day-to-day tunnel airflow requirements: calculation method . . . . .	49
Tunnel fire incident ventilation design . . . . .	50
Exposure limits for staff in tunnels . . . . .	50
Air quality monitoring and ventilation control . . . . .	50
Acceptable tunnel air quality (interior) . . . . .	51
External environmental conditions . . . . .	53
Meteorological . . . . .	53
Effects on ambient air quality . . . . .	53
Ventilation system safeguards and system reliability . . . . .	53
Reliability . . . . .	54
Jet fan redundancy . . . . .	54
Axial fan / centrifugal fan redundancy: . . . . .	54
Ventilation fans . . . . .	54
Fan motors . . . . .	54
Axial fans . . . . .	54
Jet fans . . . . .	55
Fan reversibility . . . . .	55
Fan speed and reversal control . . . . .	55
Fire rating of fans . . . . .	56
Noise levels . . . . .	56
Tunnel ventilation design report . . . . .	56
<b>6. Lighting design</b>	<b>57</b>
General . . . . .	57
Standby lighting . . . . .	58
Tunnel lighting luminaires . . . . .	58
Location of luminaires . . . . .	59
Environmental conditions . . . . .	59
Road surface reflectance . . . . .	59
Tunnel lighting control and monitoring system . . . . .	59
Whole life costs . . . . .	60

<b>7. Drainage system design</b>	<b>62</b>
General	62
Drainage systems	62
Effluent standards: consultation with authorities	64
Inflows into the tunnel	64
Precipitation and runoff	64
Wall washing	64
Fire fighting water	64
Wash-down water	64
Sumps, separators and pumping stations	64
Impounding sump	65
Pumping plant	66
Discharge pipework	67
Safety	68
Fire precautions	68
<b>8. Fire engineering</b>	<b>70</b>
General	70
Management of fire risk	70
Safe evacuation & structural damage limitation	70
Environmental issues	71
Tunnel passive fire protection	71
Tunnel structure	71
Cables & equipment	71
Secondary cladding	72
Design fire loading for structural fire protection	72
Vehicle fire	72
Passive fire protection system	74
Design requirements	74
Active fire protection requirements	75
Design fire magnitude selection for ventilation	75
Water-based fixed firefighting systems	75
Emergency panels in tunnels	76
Fire extinguishers	78
Hose reels	78
Public emergency roadside telephones	78
Communications	79
Smoke control panels	79
Fire main and hydrants	79
Automatic fire detection	81
Emergency doors and cross-passages	81
Emergency exit signage ('wayfinding signs')	84
Evacuation lighting	85
Service buildings and plant rooms	85
General	85
Fixed gas discharge extinguisher systems	85
Tunnel drainage sumps	86
<b>9. Traffic control, communications and information systems</b>	<b>87</b>
General	87
Connection to remote traffic control centres	87
General design	88
Communications infrastructure and cabling	89
Emergency telephone system	89
Radio rebroadcast systems	90
Public address voice alarm systems (PAVA)	90
Signs and signals	92

Variable message signing . . . . .	92
Portal/lane control signals . . . . .	92
Motorway matrix signals . . . . .	93
Tunnel closures systems . . . . .	93
Illuminated lane markers . . . . .	94
Automatic incident detection systems . . . . .	94
Closed-circuit television (CCTV) . . . . .	95
Traffic monitoring and vehicle detection . . . . .	96
Over-height vehicle detection . . . . .	96
Speed enforcement . . . . .	97
<b>10. Plant monitoring and control</b>	<b>98</b>
General requirements . . . . .	98
Safety integrity level . . . . .	98
System architecture . . . . .	98
Communications networks . . . . .	99
Fault tolerance . . . . .	99
Design life . . . . .	100
Environmental conditions . . . . .	100
SCADA functional requirements . . . . .	100
SCADA hardware requirements . . . . .	101
SCADA software requirements . . . . .	102
SCADA operator interface . . . . .	102
SCADA user groups . . . . .	102
SCADA alarms, data logging & reports . . . . .	103
PLC functional requirements . . . . .	104
PLC outstations . . . . .	104
PLC hardware requirements . . . . .	105
PLC software requirements . . . . .	105
Field instrumentation & equipment . . . . .	106
Uninterruptible power supplies . . . . .	106
Testing and inspection . . . . .	107
<b>11. Electrical power supply and distribution</b>	<b>108</b>
General requirements . . . . .	108
Fault tolerance . . . . .	108
Design life . . . . .	108
Environmental conditions . . . . .	108
Maintainability . . . . .	109
Incoming power supply arrangement . . . . .	109
Demand assessment . . . . .	109
Distribution network operator (DNO) consultation . . . . .	109
High voltage (HV) system . . . . .	110
HV switchgear . . . . .	110
HV cabling . . . . .	110
Transformers . . . . .	110
HV protection systems . . . . .	110
Fireman's switch . . . . .	111
Low voltage (LV) system . . . . .	111
LV switchboards . . . . .	111
Protection systems . . . . .	111
Power factor . . . . .	112
Harmonics . . . . .	112
3-phase supply . . . . .	112
Energy monitoring . . . . .	112
Distribution panels . . . . .	112
Lighting circuits . . . . .	113

Ventilation fan circuits . . . . .	113
Earthing & bonding . . . . .	113
Standby power . . . . .	113
Uninterruptible Power Supply (UPS) . . . . .	114
Standby generating plant . . . . .	115
Cabling . . . . .	116
Services in the tunnel . . . . .	116
Services below ground (outside the tunnel) . . . . .	117
Services in switchrooms and services buildings . . . . .	117
Cable design requirements . . . . .	117
Cable and termination identification . . . . .	117
<b>12. Tunnel service buildings and plant rooms</b>	<b>118</b>
General . . . . .	118
High-voltage (HV) equipment rooms . . . . .	119
Standby generators and fuel storage tanks . . . . .	119
Low-voltage (LV) equipment rooms . . . . .	119
UPS battery room . . . . .	119
Control and communications equipment rooms . . . . .	120
Local control room . . . . .	120
Building services . . . . .	121
Lightning protection . . . . .	121
Intruder alarm system . . . . .	121
Fire alarm and extinguishing systems . . . . .	121
External areas . . . . .	121
<b>13. Normative references</b>	<b>123</b>
<b>14. Informative references</b>	<b>127</b>
<b>Appendix A. Planning safety and general design</b>	<b>128</b>
A1 Establishment of tunnel profile . . . . .	128
A1.1 Service tunnels . . . . .	128
A1.2 Space for equipment . . . . .	128
A1.3 Space requirements for ventilation . . . . .	128
A1.4 Space requirements for drainage . . . . .	129
A1.5 Space requirements for lighting . . . . .	129
A1.6 Space requirements for signs and signals . . . . .	129
A1.7 Space for loudspeakers . . . . .	129
A1.8 Tunnel service buildings & tunnel portals . . . . .	130
A1.9 Space requirements for secondary cladding and passive fire protection . . . . .	130
A1.10 Space requirements for cabling, pipework and ducted services . . . . .	131
A1.11 Utilities . . . . .	131
A2 Tunnel Design and Safety Consultation Group (TDSCG) requirements . . . . .	131
A2.1 General . . . . .	131
A2.2 Topic list . . . . .	131
A3 Safety issues . . . . .	133
A4 Planning for emergencies . . . . .	134
A5 ADR (Accord Dangereux Routier) (European regulations concerning the international transport of dangerous goods by road) . . . . .	134
A6 Wall finishes . . . . .	135
<b>Appendix B. Drainage</b>	<b>136</b>
B1 Factors influencing groundwater inflows into tunnels . . . . .	136

## Latest release notes

Document code	Version number	Date of publication of relevant change	Changes made to	Type of change
CD 352	0.0.1	November 2024	Core document	Incremental change to notes and editorial updates

Release Notes: [Version 0.0.1: Publication November 2024] Deletion of MCHW references (Series 7000), (Note 3 to clause 1.2.1 deleted), and updated branding from Highways England to National Highways.

## Previous versions

Document code	Version number	Date of publication of relevant change	Changes made to	Type of change
CD 352	0	March 2020		

## Foreword

### Publishing information

This document is published by National Highways.

This document supersedes BD 78/99, which is withdrawn. Any specific requirements for Overseeing Organisations alternative or supplementary to those given in this document are given in National Application Annexes to this document.

Road tunnel matters relating to maintenance and documentation are covered in the DMRB documents CM 430 [Ref 12.I], CS 452 [Ref 41.N], and CG 302 [Ref 3.I].

### Contractual and legal considerations

This document forms part of the works specification. It does not purport to include all the necessary provisions of a contract. Users are responsible for applying all appropriate documents applicable to their contract.

# Introduction

## Background

This document provides requirements, advice, and guidance relevant to the planning, design, operation of new works and major refurbishment of all road tunnels on the motorway and all-purpose trunk road network in the United Kingdom.

Since the publication of BD78/99 in August 1999 a number of high profile incidents in heavily trafficked road tunnels across the world have involved significant loss of life and changes in provisions in tunnels for safe operation. As a result, BD78 is now very dated. As examples the following, which are important for design of both new and upgraded tunnels, are not reflected in the BD78/99:

- 1) Road Tunnel Safety Regulations introduced in 2007 UKSI 2007/1520 [Ref 77.N] stemming from the European Road Tunnel Safety 2004/54/EC [Ref 13.I] following research undertaken in the wake of the serious tunnel fires, including Mont Blanc, Tauern and Gotthard in the early years of this century;
- 2) technology advances over the last 17 years particularly in fire detection and suppression, protection of assets from fire damage and long-life light sources;
- 3) evolution of tunnel operational practices recognising higher traffic volumes and input/feedback from emergency services, impact of research into areas including emergency evacuation, fire sizes, detection and suppression, post-incident recovery, primary safety for tunnel users, behaviour of tunnel users, effective signalling and signing, control and surveillance.

The following topics are included in the document:

### Section 2:

describes factors influencing the design of road tunnels in order to establish the broad planning and safety issues that are involved at the design stage of both new build and (as far as is relevant) refurbishment projects.

### Section 3:

outlines operational safety facilities to be provided in road tunnels, such as emergency panels, pedestrian access, escape routes, vehicle crossovers and equipment relating to emergency response, ventilation override, traffic surveillance and control, communication and information systems.

### Section 4:

gives the requirements for the geometric design of carriageways within road tunnels and the provisions to be made for traffic space in relation to the structure and form of tunnel that has been chosen. Geometric design and traffic space requirements are presented from the standpoint of providing safe passage, under free-flow conditions, for the type of traffic that is permitted to use the tunnel.

### Section 5:

provides the design requirements and advice for tunnel ventilation systems to supply sufficient fresh air to all parts of the tunnel, to maintain vehicle exhaust pollutants within prescribed limits, to provide a tenable environment for tunnel users, the local community and any amenities likely to be affected by the discharge of fumes from the tunnel, and for control of smoke and hot gases in tunnel fire incidents.

### Section 6:

sets out the requirements for the design of tunnel lighting, including standby lighting, together with the monitoring and control system, and whole-life costs.

### Section 7:

gives requirements and advice for the design of tunnel drainage systems. It provides supporting information and technical criteria relating to the collection and discharge of inflows, the siting and sizing

of sumps, separators and pumping stations, including related operational and safety aspects. It outlines the procedures to comply with effluent standards and the requirements of the local water authority.

**Section 8:**

describes the requirements for fire safety assessment of road tunnels, and the plant and safety facilities to be provided as active fire protection for tunnel users. It also gives guidance on the criteria for the evaluation of fire loading to be used in Section 5 (Ventilation requirements) and for the passive fire protection of tunnels in the form of protection to structural elements, cabling, mechanical and electrical plant, and the fire and smoke resistance of doors, fixtures and fittings.

**Section 9:**

describes the provisions to be made for the design and authorisation of traffic control, communications and information systems for tunnels. In this context 'tunnels' includes the relevant approach and exit roads coming within the limits of the operating regime for the tunnel.

**Section 10:**

sets out the requirements for the design of a programmable logic controller (PLC)-based plant monitoring and control system (PM&CS) to process information received from equipment and instrumentation located in or close to the tunnel, and to determine the optimum mode of operation.

**Section 11:**

describes the provision to be made for the supply and distribution of electrical power for the tunnel equipment and services, and installed to provide safe conditions for the full range of operational requirements including emergencies.

**Section 12:**

describes the provision to be made for housing the main electricity substation, mechanical and electrical equipment and a local facility for a tunnel to facilitate management of operations and maintenance.

**Assumptions made**

The assumptions made in GG 101 [Ref 42.N] apply to this document.

**Mutual Recognition**

Where there is a requirement in this document for compliance with any part of a "British Standard" or other technical specification, that requirement may be met by compliance with the Mutual Recognition clause in GG 101 [Ref 42.N].

## Abbreviations

Abbreviation	Definition
AA	Administrative authority
AADT	Annual average daily traffic (per tunnel bore unless otherwise stated)
ACB	Air circuit breaker
ADR	Originally an abbreviation of the French term 'Accord europeen relatif au transport international des marchandises Dangereuses par Route'. (This is the European Agreement concerning the international carriage of dangerous goods by road, made under the United Nations Economic Commission for Europe.)
AFFF	Aqueous film-forming foam
AIP	Approval in Principle
ALARP	As low as is reasonably practicable
APEA	Association for Petroleum & Explosives Administration
ATEX	Appareils destines a utilise ATmospheres EXplosibles. 'ATEX' is an abbreviations used to describe the ATEX Directive. It is a set of European Union regulations that ensure products used in explosive atmospheres are safe. ATEX is short for 'Atmospheres Explosibles'.
ATEX100	A zone identified in the ATEX Directive (above)
BA	Breathing apparatus
BEIS	Business, energy and industrial strategy
BHRG	British Hydromechanics Research Group (formerly BHRA)
BIM	Building information modelling
BRE	Building Research Establishment
BSI	British Standards Institution
CFC	Chlorofluorocarbon
CFD	Computational fluid dynamics
CHARM	Common Highways Agency and Rijkswaterstaat Model
CIBSE	Chartered Institute of Building Services
CIE	Commission Internationale d'Eclairage (International Commission on Illumination)
CIRIA	Construction Industry Research and Information Association
CO	Carbon monoxide
CO <sub>2</sub>	Carbon dioxide

(continued)

<b>Abbreviation</b>	<b>Definition</b>
COTS	Commercial off-the-shelf
CPC	Circuit protective conductor
CPNI	Centre for the Protection of National Infrastructure
CPU	Central processing unit
D&B	Design and build
DARTS	'Durable and reliable tunnel structures' European thematic network
dB	decibel
dB(A)	decibel related to sound level curve 'A'
DBFO	Design, build, finance and operate
DEFRA	Department for Environment, Food and Rural Affairs
DfT	Department for Transport
DG-QRAM	Dangerous goods quantified risk assessment model
DIN	Deutsches Institut für Normung (German standards institute)
DITM	Driver information and traffic management
DNO	Distribution network operator
DP	Distribution panel
DP	Double pole
DP	(Tunnel) distribution panel
DSEAR	Dangerous Substances and Explosive Atmosphere Regulations - UKSI 2002/2776 [Ref 73.N]
E&M	Electrical and mechanical
EC	European Commission
EDP	(Tunnel) emergency / distribution panel
EHO	Environmental health office/ officer
ELV	Extra-low voltage (less than 50 volts AC or 120 volts DC between conductors, or between conductors and earth).
EMC	Electromagnetic compatibility
EMS	Electronic message sign
ENA	Energy network association
EP	(Tunnel) emergency panel

(continued)

<b>Abbreviation</b>	<b>Definition</b>
EPROM	Erasable programmable read-only memory
ERT	Emergency roadside telephone
ESN	Emergency services network
EU	European Union
FFFS	Fixed fire-fighting system
FIT	'Fire in tunnels' European thematic network
FMCEA	Failure mode effects and criticality analysis
FOSD	Full overtaking sight distance
FRP	Fire rendezvous point
FRS	Fire and rescue services
FTMS	Fixed text message sign
GD	General directive document
GRC	Glass(fibre)-reinforced concrete
GRP	Glass(fibre)-reinforced plastic
HC	Hydrocarbon
HCl	Hydrogen chloride (or hydrochloric acid)
HGV	Heavy goods vehicle
HIOCC	High incident occupancy algorithm
HMI	Human/machine interface
HRC	High rupturing capacity
HRNS	Highly resilient network system
HRR	Heat release rate
HSE	Health and Safety Executive
HV	High voltage (exceeding 1,000 volts AC or 1,500 volts DC between conductors, or 600 volts AC or 900 volts DC between conductors and earth).
HVAC	Heating, ventilating and air conditioning
IBA	Independent Broadcasting Authority
IEC	International Electrotechnical Commission
IEEE	Institute of Electrical and Electronics Engineers
IET	The Institution of Engineering and Technology

(continued)

<b>Abbreviation</b>	<b>Definition</b>
I/O	Input / output
IP	Ingress protection
IP/APEA	Institute of Petroleum/Association for Petroleum and Explosives Administration
ISMC	International Society for Measurement and Control (formally Instrument Society of America)
ISO	International Organisation for Standardization
ISTSS	International Symposium on Tunnel Safety and Security
ITS	Intelligent transport (or traffic) systems
LA10,24	Ambient sound level exceeded for 10% of a 24-hour period
LCD	Liquid crystal display
LCS	Lane control signal
LEL	Lower explosive limit
LPG	Liquid petroleum gas
LS0H	Low smoke zero halogen
LSF	Low smoke and fume
LV	Low voltage (between 50 and 1,000 volts AC or 120 and 1,500 DC between conductors, or between 50 and 600 volts AC, or 120 and 900 volts DC between conductors and earth).
M&E	Mechanical and electrical
MCB	Miniature circuit breaker
MCC	Motor control centre
MCCB	Moulded case circuit breaker
MCHW	Manual of Contract Documents for Highway Works
MEPS	European minimum energy performance standard
MICC	Mineral insulated copper covered
MICS	Mineral insulated copper sheathed
MIDAS	Motorway incident detection and automatic signalling
MTBF	Mean time between failures
MOR	Minimum operating requirements
MTTR	Mean time to repair
NFPA	National Fire Protection Association

(continued)

<b>Abbreviation</b>	<b>Definition</b>
NMCS	National motorway communications systems
NMU	Non-motorised user
NO	Nitric oxide
NO <sub>2</sub>	Nitrogen dioxide
NO <sub>x</sub>	A mixture of nitric oxide and nitrogen dioxide. (Also a generic term for all nitrogen oxides but mainly in air pollution).
NRTS	National roads telecommunications services
OECD	Organisation for Economic and Cooperative Development
OFCOM	Office of Communications
O&M	Operation and maintenance
PAVA	Public address/voice alarm
PIARC	World Roads Association PIARC (Permanent International Association of Road Congresses)
PID	Proportional integral derivative
PLC	Programmable logic controller
PM&CS	Plant monitoring and control system
ppb	Parts per billion
ppm	Parts per million
PRM	Person with restricted mobility
PSTN	Public switched telephone network
PTZ	Pan, tilt and zoom
QRA	Quantified risk assessment
RCD	Residual current device
REF	Restricted earth fault
RF	Radio frequency
RFI	Radio frequency interference
RIO	Remote input/output
RH	Relative humidity
RMS	Root mean square value (of voltage)
ROM	Read-only memory
RR(FS)O	Regulatory Reform (Fire Safety) Order 2005 UKSI 2005/1541 [Ref 76.N]

(continued)

<b>Abbreviation</b>	<b>Definition</b>
RTSR	Road Tunnel Safety Regulations 2007SI 2007/1520 [Ref 40.N] as amended by the Road Tunnel Safety (Amendment) Regulations 2009 UKSI 2009/64 [Ref 59.N]
RVP	Rendezvous point
RWS	Rijkswaterstaat (The Dutch Ministry of Infrastructure and the Environment)
SCADA	Supervisory control and data acquisition
SCP	Smoke control panel
SELV	Separated extra-low voltage system (electrically separated in such a way that a single fault cannot give rise to the risk of electric shock)
SF <sub>6</sub>	Sulphur hexafluoride
SfA	Sewers for adoption
SIL	Safety integrity level
SP&N	Single Pole and Neutral
SPECS	Average speed detection system (originally provided by Speed Check Services)
SRN	Strategic road network
SSD	Stopping sight distance
STI	Speech transmission index
SWA	Steel wired armoured.
TAA	Technical Approval Authority
TBM	Tunnel boring machine
TCC	Traffic control centre
TCP	Transmission control protocol
TDA	Tunnel Design Authority
TDSCG	Tunnel Design and Safety Consultation Group
TERN	Trans-European Road Network
TETRA	Terrestrial trunk road airwave
TOA	Tunnel Operating Authority
TP	Triple pole
TPN or TP&N	Triple pole and neutral
TRL	Transport Research Laboratory (now TRL Ltd.)
TSB	Tunnel service building

(continued)

<b>Abbreviation</b>	<b>Definition</b>
TSRGD	Traffic Signs Regulations and General Directions UKSI 2016/362 (TSRGD) [Ref 78.N]
UPS	Uninterruptible power supply
UPTUN	'UPgrading methods for fire safety in existing TUNnels' European thematic network
UTMC	Urban traffic management and control
VAID	Video-based automatic incident detection
VMS	Variable message sign
WEL	Workplace exposure limit
WTC	World Tunnelling Congress
WHO	World Health Organisation
WRc	Water Research Centre
XLPE	Cross-linked polyethylene

## Terms and definitions

### Terms

Term	Definition
Administrative authority (for tunnel).	In the context of the RTSR UKSI 2007/1520 [Ref 77.N], within Highways England this is the Chief Highway Engineer of Highways England. For the Devolved Administrations it is an organisation or individual appointed by the Overseeing Organisation.
Approval in Principle	The document, which records the agreed basis and criteria for the detailed design or assessment of a highway structure
As low as reasonably practicable (ALARP)	This is when there is gross disproportion between the cost of the measures for averting a risk in terms of money, time, trouble, and the quantum of the risk. To be agreed with the TDSCG.
Design, Build, Finance, and Operate	Delivery approach through which a single entity designs, builds, finances and operates a project for a specified period. DBFO contracts are Private Finance Initiative (PFI) contracts where the "ownership" of an asset has been passed to the third party for them to operate and maintain for a significant (25+ years) period. With DBFO contracts, responsibility for the decisions regarding maintenance and improvement remains with the DBFO Company
Hard shoulder	A hardened strip alongside a motorway for stopping on in an emergency.
Hard strip	See 'hard shoulder'.
Road tunnel	A subsurface highway structure enclosed for a length of 15 0m, or more, measured along the centre line of the soffit.
Emergency services	All local services that may be called upon to intervene in the event of an accident or incident, including the police, fire and rescue services, ambulance services, traffic officers and tunnel operational staff.
Motorway and all-purpose trunk road network	Collective term to indicate those parts of the UK highway and road network for which one of the Overseeing Organisations is or acts on behalf of the highway or road authority
Overseeing Organisation	Highways England and the highways or roads authorities of the Devolved Administrations of Scotland, Wales and Northern Ireland and their successors. (The meaning of Overseeing Organisation is typically defined by the contract under which the works are procured.)
Technical Approval Authority	The organisation responsible for agreeing the Approval in Principle and acceptance of design and check certification

**Terms** (continued)

Trans-European Road Network	The network of roads designated by the European Parliament as being strategically important for Europe-wide transport
Tunnel Design and Safety Consultation Group	A consultation group made up of interested parties, convened for the purpose of reviewing and co-ordinating proposals for the design and operation of a road tunnel
Tunnel manager	The individual or, in some cases, the organisation, responsible for management of the tunnel. Specific duties of the tunnel manager are defined in the RTSR.
Tunnel operating authority	The organisation responsible for day-to-day operation of the tunnel.
Tunnel safety officer	An independent individual responsible for monitoring and advising on issues relating to road tunnel safety. Specific duties of the tunnel safety officer are defined in the RTSR

# 1. Scope

## Aspects covered

- 1.1 This document provides requirements and advice, that shall be complied with in the planning and design of new or the major refurbishment of all road tunnels on the motorway and all-purpose trunk road network in the United Kingdom.

*NOTE For the purposes of this document a road tunnel is defined as a subsurface highway structure enclosed for a length of 150m, or more, measured along the centre line of the soffit.*

- 1.2 All tunnels falling within the scope of the RTSR UKSI 2007/1520 [Ref 77.N] must satisfy the requirements of RTSR UKSI 2007/1520 [Ref 77.N] or this document, if more onerous.

- 1.2.1 The RTSR UKSI 2007/1520 [Ref 77.N] should be complied with for all road tunnels that form part of the TERN, and are in excess of 500m length.

*NOTE 1 Although the design principles applicable to the road space and equipment within a tunnel are similar for all road tunnels, each tunnel will be unique in terms of the civil and structural design and methods of construction. For this reason references to civil engineering aspects of design within this document are necessarily limited to aspects common to most tunnels such as space requirements for traffic, equipment, escape routes, and fire protection of the structure.*

*NOTE 2 Due to the wide variation in the engineering considerations that influence the structure and form of a tunnel, references to civil engineering aspects within the document are necessarily limited in scope.*

*NOTE 3 The requirements and advice provided in this document have been harmonised with the Road Tunnel Safety Regulations 2007 UKSI 2007/1520 [Ref 77.N] and the Road Tunnel Safety (Amendment) Regulations 2009 ( UKSI 2009/64 [Ref 59.N]) together referred to as the 'RTSR'.*

*NOTE 4 Requirements and advice relating to maintenance and documentation requirements, are covered in CM 430 [Ref 12.I] , CS 452 [Ref 41.N] , CG 302 [Ref 3.I] and CS 450 [Ref 10.I].*

## Implementation

- 1.3 This document shall be implemented forthwith on all schemes involving the planning and design of all new build and refurbishment road tunnel projects on the Overseeing Organisations' motorway and all-purpose trunk roads according to the implementation requirements of GG 101 [Ref 42.N].

## Use of GG 101

- 1.4 The requirements contained in GG 101 [Ref 42.N] shall be followed in respect of activities covered by this document.

## 2. Planning, safety and general design

### General

- 2.1 For each project containing a road tunnel, a review of factors contributing towards a safe tunnel environment for road users, local inhabitants, third parties and neighbouring properties, operators, maintenance staff, emergency services and consultations with independent watch dogs representing interests of major road users, shall be undertaken during the development of the tunnel proposals.
- 2.1.1 The design of tunnel options should initially be to the same highway standards as for open road options.
- 2.1.2 The following information, at least in preliminary form, should be obtained before design commences, in order to inform the design:
- 1) the route and alignment of the tunnel;
  - 2) topography, hydrogeology and geotechnical information;
  - 3) surface water or fluvial flood risk;
  - 4) the class of road and design speed limit;
  - 5) the minimum level of availability for the tunnel;
  - 6) available diversion routes;
  - 7) available opportunities for planned maintenance closures;
  - 8) anticipated peak and average traffic density, including a breakdown of vehicle types;
  - 9) any known hazardous goods traffic and route ADR classification;
  - 10) likely to be designated as high or abnormal load route;
  - 11) emergency services and breakdown recovery capabilities and response times;
  - 12) means of escape from, and emergency services access to, potential incident sites;
  - 13) available mains power and water supplies;
  - 14) drainage catchment areas and outfall locations;
  - 15) location of monitoring and control facilities;
  - 16) any specific environmental constraints (such as for noise, air quality, and impact on biodiversity);
  - 17) target costs and timescales for construction;
  - 18) extents of design responsibilities, interfaces and deliverables, particularly where different parties carry out different stages of the design;
  - 19) for existing tunnels, the availability of relevant record drawings, operation and maintenance manuals, specifications and design calculations relating to the existing structure and equipment, together with (for tunnels covered by the Road Tunnel Safety Regulations 2007 ( UKSI 2007/1520 [Ref 77.N]) all pertinent safety documentation and operational risk assessments;
  - 20) Imminent land planning considerations;
  - 21) customer perception/expectations/views of road tunnels. Refer Transport Focus Research and Publications.
- 2.1.3 The following issues have an important bearing on the overall tunnel design, and should be taken into account early in the planning process:
- 1) the starting point for design is that road standards and through-route objectives are maintained in the tunnel;
  - 2) provision of a stopping lane and verge widths have an important bearing on cross-section and cost;
  - 3) penalties for steep gradients are more severe than on the open road (for example costs associated with the provision of climbing lanes and additional ventilation to cope with the gradient and increased exhaust emissions);
  - 4) tunnel design speed to be the same as that on the approach roads;

- 5) likely traffic speed changes in tunnel;
- 6) provision of alternative routes for road users excluded from tunnels;
- 7) junctions in tunnels are undesirable because of restricted sight lines, conflicting vehicle movements and ventilation issues.

**NOTE 1** *A number of characteristics of roads in tunnels differ from open roads. These include capital, operating and whole-life costs, and ventilation, lighting and maintenance requirements.*

**NOTE 2** *The nature and mix of vehicles in the traffic flow will also affect the physical design of tunnels; for example flows with a higher percentage of HGVs can require extra ventilation, especially at steeper gradients.*

**NOTE 3** *It is important, for informed design progress on other aspects of the road tunnel design, to establish the location, cross sectional shape and gradient profiles for the tunnel as early as possible in the planning process.*

2.2 Value engineering decisions shall be documented in agreement with the OO, with records of the data used, the reasons for accepting or rejecting each option, and any consequential impacts on other systems or equipment.

### **General design**

2.3 When assessing the strategic implications of the design of new and refurbished tunnels, reference shall be made to the appropriate National Application Annex (NAA).

2.4 The tunnel civils, mechanical, electrical, control and communications systems shall be designed to minimise whole life costs, including operating, maintenance, energy and plant replacement costs, as well as to maximise the road availability and safe access for maintenance.

**NOTE 1** *It can be appropriate and more cost effective over the whole life of a system to accept greater capital costs initially that allow savings through greater reliability, longevity and/or reduced service intervals.*

**NOTE 2** *The six key elements of a road tunnel design or refurbishment normally relate to:*

- a) *for a new tunnel, the tunnel profile and protection of the tunnel structure against accidental damage, such as fire, from vehicle collisions, or spills;*
- b) *the role and extent of the equipment and plant that is required to monitor communicate and control the tunnel environment and respond to tunnel emergencies. The level of future maintenance and operational costs are closely correlated to the level of installation of such equipment and plant;*
- c) *whether the tunnel is to be permanently staffed or operated remotely;*
- d) *the tunnel maintenance and operating procedures required to facilitate day-to-day operation and to respond to emergency conditions;*
- e) *the number and duration of tunnel closures during which preventative and corrective maintenance works can be efficiently carried out;*
- f) *minimising failures affecting minimum operating requirements.*

**NOTE 3** *Information on tunnel profile, service tunnels and spaces in the tunnel for equipment, ventilation, lighting, drainage, signs and signals, loudspeakers, secondary cladding, passive fire protection, utilities, cabling pipework and ducted services, and tunnel service buildings is given in Appendix A.*

**NOTE 4** *Information on the process for selection of appropriate tunnel type is outlined in clause 2.29.*

2.5 Tunnel mechanical and electrical systems and control and communications systems shall be designed so that no single equipment or power supply failure will result in an unsafe situation or an inability to maintain normal traffic flow or close the tunnel to traffic as set out in the MOR.

2.5.1 Electrical, mechanical, control and communications equipment should be installed in locations where safe access can be gained without the need for lane or tunnel bore closures.

2.5.2 Components with limited life should be designed for ease of replacement with a minimum of tools and access equipment.

- NOTE 1* Components with limited life such as, tunnel lighting lamps and control gear will need replacement periodically or on hours run.
- NOTE 2* Components that can be replaced as quickly and easily could be selected.
- NOTE 3* Non-standard or bespoke items such as secondary cladding panels, access covers, drainage gully gratings, emergency distribution panels and signs, tunnel lighting luminaires and jet fans can be difficult to replace quickly unless a stock of spares is maintained.

### Technical approval

- 2.6 The requirements for technical approval of the road tunnel structure and equipment shall be in accordance with CG 300 [Ref 70.N].

### Regulatory reform (fire safety) order (RR(FS)O)

- 2.7 The relevant authority shall be consulted regarding the applicability RR (FS)O UKSI 2005/1541 [Ref 76.N], to individual tunnels.
- 2.7.1 For those tunnels required to comply with the RR (FS)O UKSI 2005/1541 [Ref 76.N], the evidence required to achieve acceptance should be agreed.
- NOTE 1* Examples of evidence required to achieve acceptance could include, a fire safety risk assessment for the tunnel and associated premises, to identify fire hazards and people at risk and implement measures to mitigate those risks.
- NOTE 2* Road tunnels on motorways and all-purpose trunk roads are normally regarded as being exempt from the RR (FS)O UKSI 2005/1541 [Ref 76.N] but tolled tunnels cannot always be exempt.
- NOTE 3* Specific guidance relating to road tunnels can be found in the Department for Communities and Local Government publication 'Fire Safety Risk Assessment: transport premises and facilities' DCLG Fire safety risk [Ref 5.I].

### The Equality Act

- 2.8 To demonstrate compliance with the Equality Act UKPGA 2010/15 [Ref 24.N] an Equality Impact Assessment (EqIA) shall be completed.
- 2.9 Means of escape, and any doors, steps, gradients, narrow walkways, etc. shall not cause difficulty to persons with protected characteristics.
- NOTE* Protected characteristics are as described in the Equality Act UKPGA 2010/15 [Ref 24.N].
- 2.10 Access to, and through, emergency doors and escape routes shall be step-free, and risk assessed with the TDSCG.
- NOTE 1* Step-free emergency doors and escape routes can be achieved by the provision of dropped kerbs and easy gradients.
- NOTE 2* Specific guidance and recommendations can be found in the Department for Transport publication Inclusive Mobility Inclusive Mobility [Ref 40.N].

### Building information modelling

- 2.11 Building information modelling (BIM) shall be used to accord with the Government Construction Strategy 2011 OG-Incidents [Ref 4.I].

### Tunnel operation

- 2.12 The tunnel design shall include for the operating, emergency, maintenance procedures and post incident recovery procedures, to be employed during its use.
- 2.13 The following shall be included in the tunnel tunnel design:

- 1) the requirements of the user of the installed equipment, including access to, and presentation of, information they require;
  - 2) the requirements of the emergency services for response to incidents;
  - 3) which systems are to be automated, which can require operator intervention, and to what extent;
  - 4) intuitive control systems that assist decision making processes and facilitate rapid response to emergency situations;
  - 5) minimum operating requirements (a breach of which can necessitate tunnel closure);
  - 6) ease of access to, and interrogation of, traffic and systems monitoring data for routine day-to-day monitoring;
  - 7) ease of access to installed equipment for maintenance and troubleshooting.
- 2.13.1 For existing tunnels, the design should take into account all relevant established operational procedures and the tunnel operating and administrative authorities consulted regarding any design proposals that entail changes to procedures.
- 2.13.2 The tunnel, closed to traffic for whatever reason, should remain closed to traffic until, through mitigation or other intervention, the tunnel is safe to reopen to permitted traffic.
- 2.14 For new tunnels, the Tunnel Design and Safety Consultation Group (TDSCG) and BS EN 794 [Ref 47.N] shall be consulted regarding operating and emergency procedures.

### **Tunnel design and safety consultation group (TDSCG)**

- 2.15 In order to confirm design parameters and operating procedures, a TDSCG shall be convened.

**NOTE** *The purpose of the TDSCG is to establish a forum within which interested parties (see below) can be acquainted with proposals for a tunnel construction or refurbishment project and have an opportunity to share their specialist knowledge and experience to clarify the design outcomes. A TDSCG normally comprises of appropriate levels of representation from:*

- 1) *the Overseeing Organisation;*
  - 2) *the designer;*
  - 3) *the Technical Approval Authority;*
  - 4) *the tunnel manager;*
  - 5) *the tunnel safety officer;*
  - 6) *the emergency services (including police, fire and rescue services, ambulance service and other organisations that can be involved in response to significant incidents);*
  - 7) *relevant environmental regulator appropriate for the specific tunnel;*
  - 8) *relevant local government authorities;*
  - 9) *on-road traffic services;*
  - 10) *competent operator and competent maintainer.*
- 2.15.1 The TDSCG should identify potential hazards involving lighting, vehicle breakdown, traffic congestion and full-scale emergencies, including fire.
- 2.15.2 Consider also how the risks should be mitigated and any associated emergency response requirements.
- NOTE 1** *A summary of the items that can normally be discussed by a TDSCG is in Appendix A2.*
- NOTE 2** *Topic items to those provided in Appendix A2 can be introduced to deal with specific issues particular to a tunnel.*
- NOTE 3** *Guidance on tunnel incident pre-planning, staged incidents, operational tactics and communications from the working group chaired by the Fire Service Inspectorate can be found in the Communities and Local Government document Fire & Rescue Service: Operational Guidance - Incidents in Tunnels and Underground Structures OG-Incidents [Ref 4.I] .*

- 2.15.3 The TDSCG should meet regularly throughout the design and construction periods.
- 2.15.4 The TDSCG should review design proposals and working procedures for day to day operation, planned maintenance requirements (including contraflow) and response to incidents and emergencies.
- 2.15.5 The TDSCG should agree ALARP where ALARP principles are applied.
- 2.15.6 In the event of an emergency, contingency plans should enable tunnel services and traffic flows to be restored.
- 2.15.7 The TDSCG should continue to meet throughout the design and commissioning stages of the project until the emergency drill requirement of CS 452 [Ref 41.N] prior to tunnel opening to traffic, has been completed and any adverse findings from the drill have been formally addressed.
- 2.15.8 The TDSCG may remain in place, and meet periodically during subsequent operation of the tunnel, to consider operational and maintenance issues that can arise through changes in legislation, technology upgrades or refurbishment. It can also be useful to review on an ongoing basis the adequacy of safety provisions and operating and emergency procedures.
- 2.16 Details of information presented to the TDSCG, along with any feedback and comments received, shall be formally recorded into a finalised safety consultation document, and appended to the Approval In Principle (AIP) document, as required by CG 300 [Ref 70.N].

### Safety

- 2.17 Preliminary proposals shall be based on consultation with the Overseeing Organisation, Technical Approval Authority (TAA), emergency services and the proposed tunnel Operating authorities.
- 2.17.1 Safety should be made prime consideration in the design for maintenance, economic running and operational safeguards.
- 2.17.2 The requirements of all organisations consulted concerning tunnel operating policy and tunnel planning, such as the locations of the traffic control centre and equipment for on-site, remote surveillance and control, support of prohibitions, cross-over facilities and emergency services requirements for incident response, should be addressed early in the design stage.
- NOTE 1** *It is important to assess options concerning tunnel operating policy and tunnel planning as there can be little or no scope for subsequent physical alteration (e.g. changing ventilation shafts, emergency access, etc.).*
- NOTE 2** *Operational and safety aspects have a significant effect on development of the detailed design, particularly of mechanical and electrical (M&E) systems functions.*
- NOTE 3** *Information on safety issues relating to operation and maintenance is included in Appendix A3.*
- 2.18 At conceptual design stage for a new or refurbishment tunnel project, potential hazards that can arise during normal day-to-day operation of the tunnel shall be identified and related to the tunnel layout and installed equipment, communications and control systems and emergency services' response, and the consequent risks evaluated.
- 2.18.1 The risk assessment should both inform the design and serve as a check on the adequacy of the design proposals, and identify any risks falling within the 'Tolerable' region (see Table 2.18.3) that can need further mitigation.
- 2.18.2 The risk assessment may be used to inform the process of determining the minimum operating requirements for the tunnel, i.e. the minimum combinations of conditions, availability of systems and procedures for safe continued operation of the tunnel.
- 2.18.3 The example risk assessment methodology illustrated in Tables 2.17.3a, and 2.17.3b gives an example of a typical risk assessment matrix for a road tunnel. Probability definitions should be selected to cope with the wide range of potential hazard probabilities that appertain to a road tunnel.

**Table 2.18.3a Example of assessment matrix for risks to tunnel users**

EXAMPLE OF ASSESSMENT MATRIX FOR RISKS TO TUNNEL USERS					
Probabil- ity	Severity				
	Minor damage or loss, no injury	Slight injury or illness, moderate damage or loss	Serious injury or illness, substantial damage or loss	Fatal injury, major damage or loss	Multiple fatalities, catastrophic loss or damage
< 1 in 10 0 years	Broadly acceptable	Broadly acceptable	Tolerable	Tolerable	Unacceptable
Once every 10 - 100 years	Broadly acceptable	Tolerable	Tolerable	Unaccept- able	Unacceptable
Once every 1 - 10 years	Tolerable	Tolerable	Tolerable	Unaccept- able	Unacceptable
> 1 - 10 times per year	Tolerable	Tolerable	Unacceptable	Unaccept- able	Unacceptable
> 10 times per year	Tolerable	Unacceptable	Unacceptable	Unaccept- able	Unacceptable

**Table 2.18.3b Risk classification**

Risk classification	REQUIRED ACTION
Broadly acceptable	Ensure assumes control measures are maintained and reviewed as necessary.
Tolerable	Additional control measures needed to reduce risk to a level which is 'as low as reasonably practicable' (ALARP) for the population concerned.
Unacceptable	Activity not permitted. Hazard to be avoided or risk reduced to 'Tolerable'.

2.18.4 The reasonably foreseeable hazards that can occur both in the tunnel and on the approaches to the tunnel should be identified and design solutions developed.

2.18.5 Hazards may include :

- 1) Vehicle related incidents such as:
  - a) vehicle fires from traditional fuels and other;
  - b) road traffic collision;
  - c) vehicle travelling in the wrong direction;
  - d) vehicle breakdown;
  - e) over-height vehicle strike;
  - f) queuing traffic.
- 2) Equipment failures such as:
  - a) incoming power supply failure;

- b) lighting system failure;
  - c) ventilation system failure;
  - d) drainage pumping failure;
  - e) fixed firefighting system accidental discharge;
  - f) communications network failure;
  - g) failure of traffic signals or VMS;
  - h) CCTV system failure;
  - i) telephone system failure.
- 3) Miscellaneous such as:
- a) debris on road;
  - b) hazardous spillage;
  - c) pedestrians in the tunnel;
  - d) animals in the tunnel;
  - e) flooding;
  - f) rock fall or landslip on approach;
  - g) suspect package;
  - h) terrorist attack including security threat and/or cyber-attack.
- 4) Weather conditions including:
- a) fog;
  - b) rapid, air vapour condensation on windscreen, mirrors, etc.;
  - c) high winds;
  - d) ice & snow;
  - e) heavy rainfall;
  - f) dazzle from the sun (particularly in east - west tunnel alignments);
  - g) identification and assessment of risks due to climate change and climate extremes.
- 2.18.6 External weather conditions do not directly relate to tunnels. However, drivers encounter these when they exit a tunnel and may need to be warned before exiting.
- 2.19 A risk analysis to comply with the RTSR UKSI 2007/1520 [Ref 77.N] shall be carried out and a report produced on the proposed risk reduction measures.
- 2.19.1 Examples of design and traffic characteristics that may affect driver behaviour include traffic signs and signals and vehicle movements in the tunnel and on the tunnel approaches.
- 2.20 Subsidiary risk assessments shall be made to determine the probability and likely impact of hazards with a range of potential impacts.
- 2.20.1 The probability and severity of fires in various types of vehicle may be derived from historic data for comparable roads and tunnels, making due allowance for traffic density and composition and any known transportation of dangerous goods.
- 2.20.2 Strategies for responding to potential hazards should be based on the management, coordination, operation, mobilisation, access, procedures and communications requirements of the various parties involved and the needs of the road user, the level of human resources required during an incident, both at the control centre and on the ground.
- 2.20.3 Strategies on responses should deal with both the initial occurrence of a hazard and also any consequential developments.
- NOTE** *A breakdown in a tunnel can lead to initial local queuing which can develop into wider scale area congestion and gridlock.*
- 2.20.4 For new tunnels the selected tunnel cross section should relate to the approach road standards, geometry and visibility and procedures for dealing with incidents.

- 2.20.5 The need for provision of a stopping lane and verge widths should be assessed, because these have an important bearing on the tunnel cross-section and as secondary evacuation routes.
- 2.20.6 Any requirements for cross connections between tunnel bores or vehicular crossovers outside the tunnel portals, for the purposes of contraflow operation and emergency access should be confirmed at any early stage of the design process.
- 2.20.7 Proposed means of safe escape from the tunnel under fire scenarios including contraflow operations should be assessed.
- NOTE 1 Early warning of a fire, early activation of fire suppression measures or use of mechanical ventilation can all contribute to reducing the risk to escapees, and allow more time for evacuation to a safe location with fresh air.*
- NOTE 2 Use of static or dynamic evacuation lighting, way-finding signage, acoustic signals and/or suitable colour schemes to accentuate escape routes can also support prompt evacuation (see Section 8).*
- 2.20.8 A quantified risk analysis based on early warning of a fire, early activation of fire suppression measures or use of mechanical ventilation may be used to determine the optimum spacing between emergency escape doors.
- NOTE A further risk assessment can be carried out using a similar methodology to consider the impact of the same set of hazard events on the continuing availability of the tunnel. Inherent in this process is the development of a suite of minimum operating requirements to define the various combinations of circumstances, availability of equipment and operational procedures that can allow the tunnel to remain open to traffic while maintaining an acceptable level of safety. An example of a risk matrix for this purpose is shown in Table 2.21.*
- 2.20.9 The outcome of any further risk assessment should be used to demonstrate compliance with the tunnel availability requirements.
- 2.21 The risk assessment reports shall be appended to the AIP.

**Table 2.21a Example of assessment matrix for risks to tunnel availability**

Probability	Severity				
	Traffic disrupted for up to 20 minutes	Traffic disrupted for between 30 minutes and 90 minutes.	Traffic disrupted for between 90 minutes and one day	Traffic disrupted between one day and one month	Traffic disrupted for more than one month
1 in 100 years	Broadly acceptable	Broadly acceptable	Tolerable	Tolerable	Unacceptable
Once every 10 - 100 years	Broadly acceptable	Tolerable	Tolerable	Unacceptable	Unacceptable
Once every 1 - 10 years	Tolerable	Tolerable	Tolerable	Unacceptable	Unacceptable
> 1 - 10 times per year	Tolerable	Tolerable	Unacceptable	Unacceptable	Unacceptable
> 10 times per year	Tolerable	Unacceptable	Unacceptable	Unacceptable	Unacceptable

**Table 2.21b Risk classification**

Risk Classification	REQUIRED ACTIONS
Broadly acceptable	Ensure assumed control measures are maintained and reviewed as necessary
Tolerable	Additional control measures needed to reduce risk to a level which is 'as low as reasonably practicable' (ALARP) for the population concerned.
Unacceptable	Activity not permitted. Hazard to be avoided or risk reduced to 'Tolerable'.

### Transportation of dangerous goods

2.22 Safeguards for fires or spillages of hazardous materials shall be based on an assessment of the risk implications of traffic carrying dangerous loads (explosives, flammables, toxins and radioactive materials).

*NOTE 1 Fires or the spillage of hazardous materials are of greater consequence in tunnels than on the open road.*

*NOTE 2 The safeguard provisions made can have an impact on the structural design, basic equipping and operating criteria (to include adequate fire protection) and ventilation capacity for fire and smoke control, and apply proportioning drainage sumps to cope with spillages of hazardous material and any sluicing water, foams, etc. applied.*

2.22.1 Safeguards such as fire protection, ventilation and drainage in relation to pipelines carrying gas or chemicals belonging to third party users should be provided.

*NOTE 1 The transport of dangerous goods is governed by the Carriage of Dangerous Goods and Use of Transportable Pressure Equipment (Amendment) Regulations (SI 2011 No.1885) UKSI 2011/1885 [Ref*

5.N]. These largely apply the ADR Agreement (European agreement concerning the international carriage of dangerous goods by road) ADR Agreement [Ref 1.] but permit the imposition of further restrictions in certain areas such as tunnels.

NOTE 2 Information on the goods that can be safely transported through the tunnels is included in Appendix A5.

### Power supplies

2.23 A secondary source of power shall be provided for essential safety related services and control room operation, to cover for the possibility of total power failure.

NOTE To achieve an acceptable level of reliability for life safety systems the secondary source of power can take the form of a secondary external mains supply from an alternative source, a standby generator or, for limited duration, a battery-backed uninterruptible power supply.

2.23.1 When standby power is brought into use to permit operation of the tunnel to continue with, for example, lighting or ventilation operating at a reduced level, then measures should be imposed to ensure the safe passage of traffic and an acceptable response to incidents in conformance with MOR.

### Traffic management

2.24 At design stage traffic management shall be developed to cater for normal traffic flow and for special movements (such as abnormal loads and slow moving vehicles), maintenance activities (both planned and unplanned); and the means for implementing effective closure of a tunnel, both for planned maintenance activities and in the event of an emergency.

NOTE 1 The primary purpose of closures is to protect from oncoming vehicles the work force that can be in the tunnel, evacuees escaping from an incident, or emergency services personnel in attendance,.

NOTE 2 The use of traffic signals alone (such as lane control signals or wig-wags) can be insufficient to ensure continuing compliance and the deployment of physical barriers can be desirable after traffic has been brought to a standstill.

2.24.1 For acceptable air quality to be maintained in a tunnel and that vehicles ahead of an incident are able to leave the tunnel unimpeded, traffic management should be designed to minimise the risk of congestion in a tunnel and to keep the exit route clear.

2.24.2 The planning of signals and barriers for emergency tunnel closure should be based on the following:

- 1) how traffic can be safely slowed and brought to a halt at a safe distance from the tunnel (including traffic joining the through route from junctions);
- 2) where physical barriers are employed, how to avoid the risk of vehicles colliding with the barriers;
- 3) where physical barriers are not used, how to prevent drivers from driving past stop signs;
- 4) how to maintain access for emergency services vehicles; and
- 5) how traffic can be directed around and past obstructions/incidents.

2.25 Where physical barriers are proposed in connection with tunnels on motorways and all-purpose trunk roads, the agreement of the Overseeing Organisation for their use shall be obtained.

### Restrictions on tunnel use

2.26 Where a tunnel is to be constructed on a route used by non-motorised users, an alternative route shall be provided for their use in accordance with CD 143 [Ref 16.N] and assessed in accordance with GG 142 [Ref 84.N].

2.27 Pedestrians, pedal cycles, motor cycles with engines less than 50cc, animals and animal drawn vehicles, and mobility scooters shall not be permitted to use the tunnel.

NOTE Classes of road users such as pedestrians, pedal cycles, motor cycles with engines less than 50 cc, animals and animal-drawn vehicles, and mobility scooters are currently prohibited from motorways and, unless there is no reasonable alternative, they are also prohibited from trunk road tunnels due to the difficulties in providing safe access.

- 2.27.1 A safe route for non-motorised users may be in the form of a separate bore, a guarded walkway raised above the road surface or a walkway separated by a partition from the main tunnel, with fresh air ventilation.
- 2.28 The provision of a low-level verge shall be maintained for emergency use by vehicle occupants and to maintain the design sight-lines on bends.

**Cladding**

- 2.29 The internal walls, cladding and false ceilings etc. of a road tunnel shall be designed for an additional operational loading due to the wind pressures and 'suctions' caused by the moving vehicle traffic.
  - 2.29.1 For preliminary design nominal loading should be +/- 1.5 kPa, applied in the combinations for wind loads as defined in CS 454 [Ref 3.N] and 50 million cycles for fatigue on metal elements within the cladding.
  - 2.29.2 The nominal loading and stress cycles should be reviewed for traffic volume, traffic speed and range of vehicle heights, once the tunnel cross section and lining clearances have been determined, and for any contraflow traffic operations.
- NOTE The nominal loading values and stress cycles can vary widely from tunnel to tunnel.*
- 2.29.3 The lower part of the tunnel wall should be designed to minimise the risk of traffic collision with the secondary cladding.
  - 2.29.4 Cladding should be designed for ease of maintenance and/or replacement following damage/incidents.

**Selection of appropriate tunnel type**

- 2.30 The following procedures flowcharts shall be used to determine the tunnel type to be adopted:

**Figure 2.30a Flowchart of data acquisition actions to determine tunnel type**

**a. Acquisition of base data**

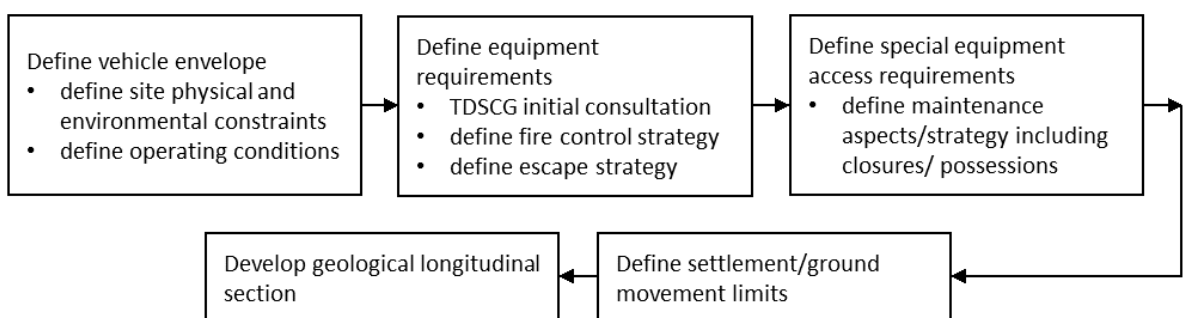

**Figure 2.30b Flowchart for tunnel geometry , types of construction method and geology**

**b. Define initial tunnel cross section/space**

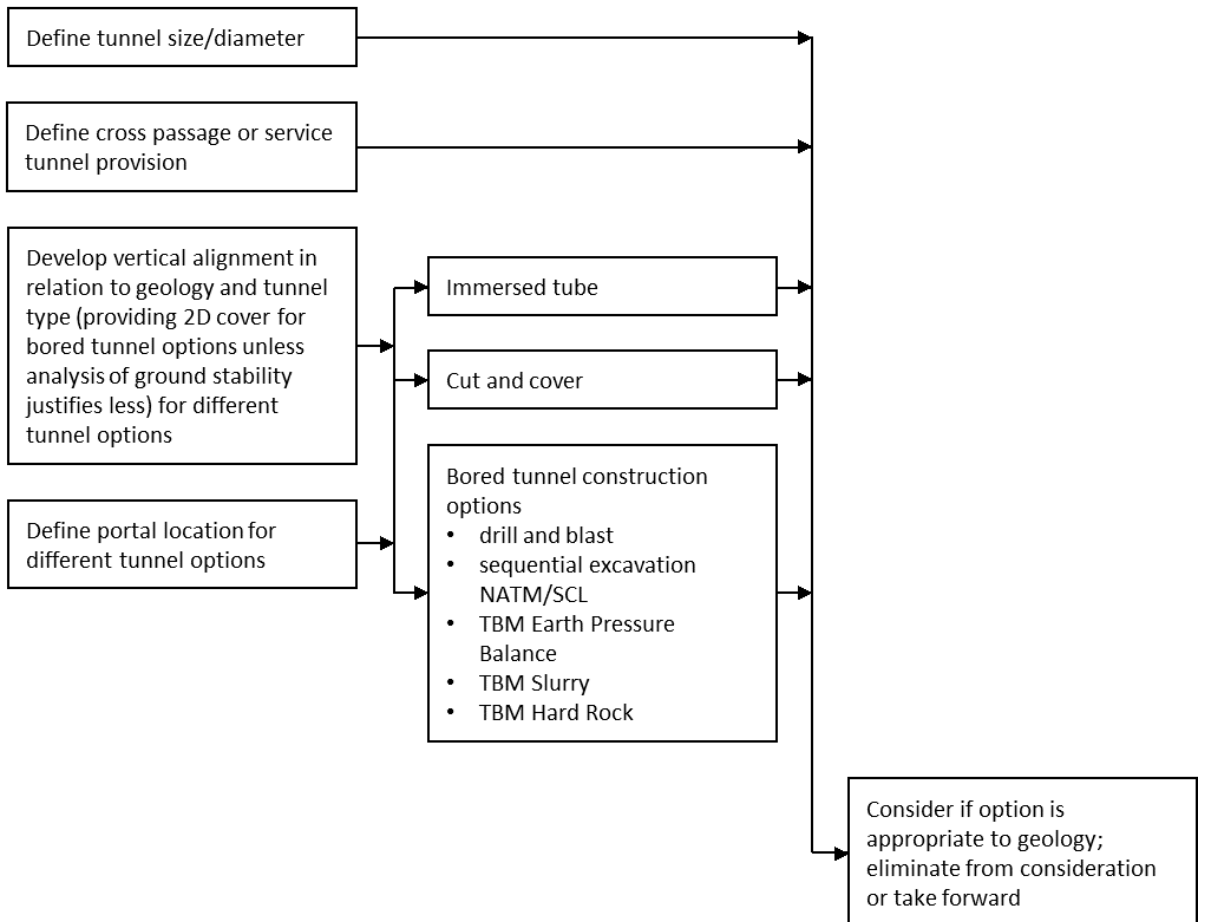

**Figure 2.30c Flowcharts of actions to develop tunnel options based on type of construction**

**c. Development of options**

**Option 1 – Cut and cover**

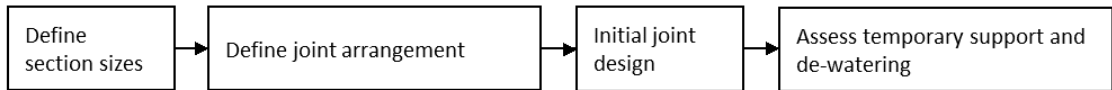

**Option 2 – Immersed tube**

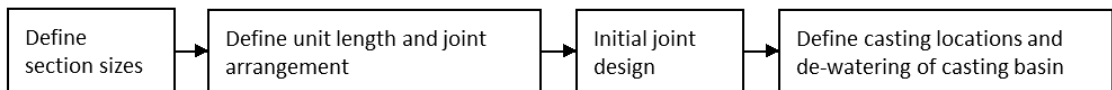

**Option 3 – Bored tunnel construction options**

**Option 3a – Drill and blast**

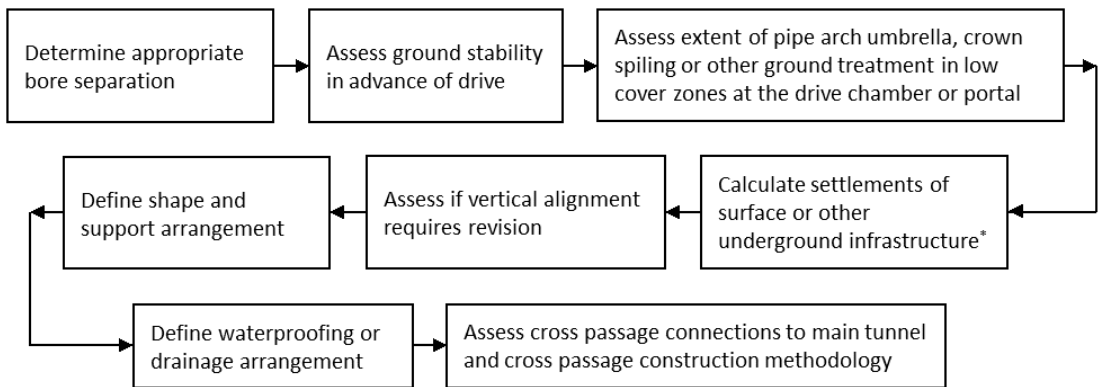

**Option 3b – Sequential excavation NATM/SCL**

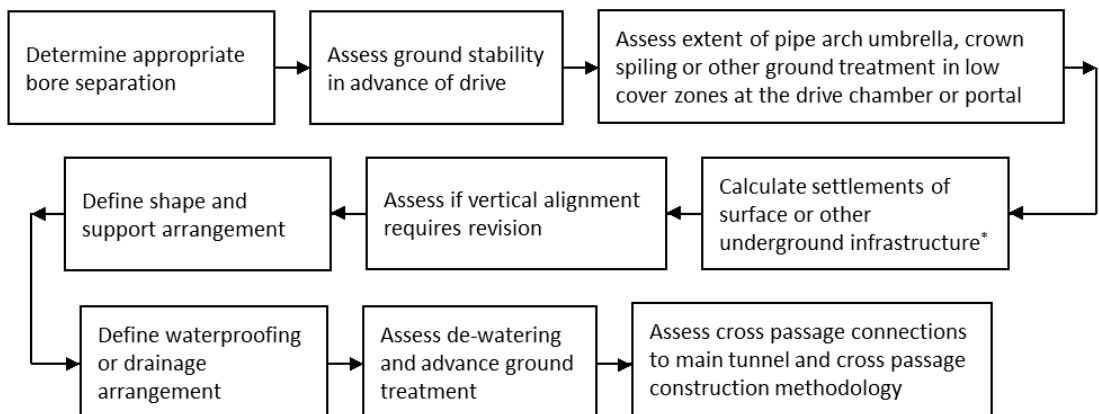
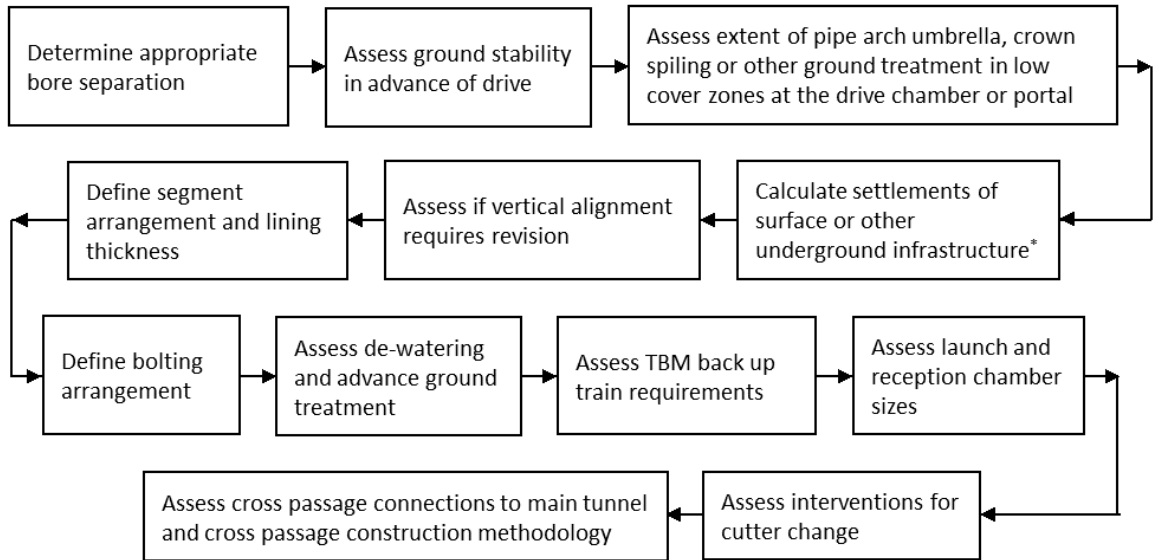
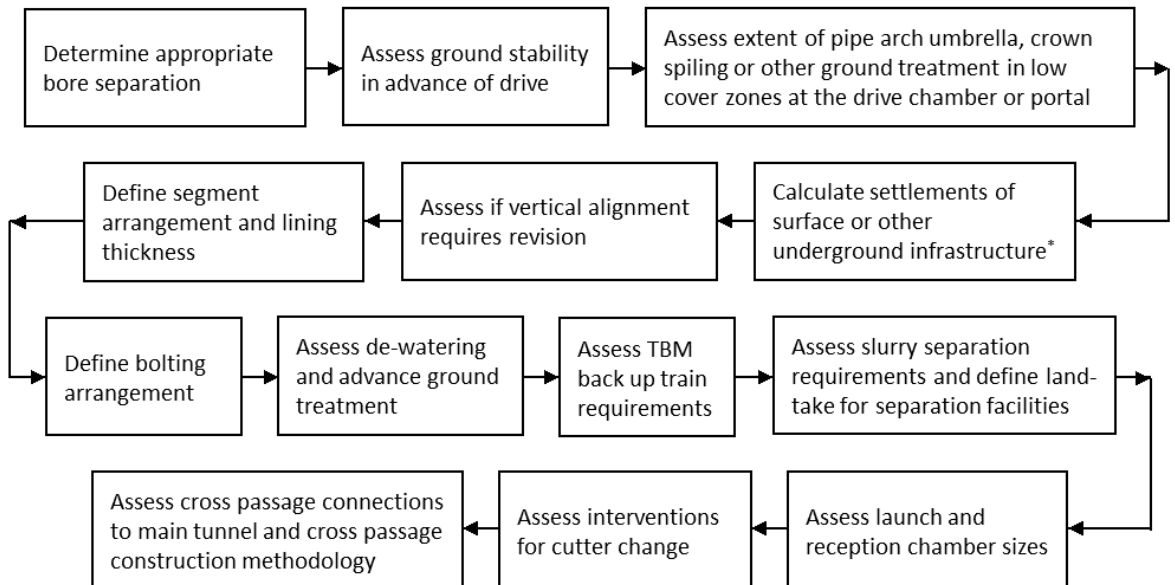

Figure 2.30d Flowcharts for types of tunnel boring machine for softer ground

Option 3c – TBM Earth Pressure Balance



Option 3d – TBM Slurry



**Figure 2.30e Flowchart for using a hard-rock tunnel boring machine**

Option 3e – TBM Hard Rock

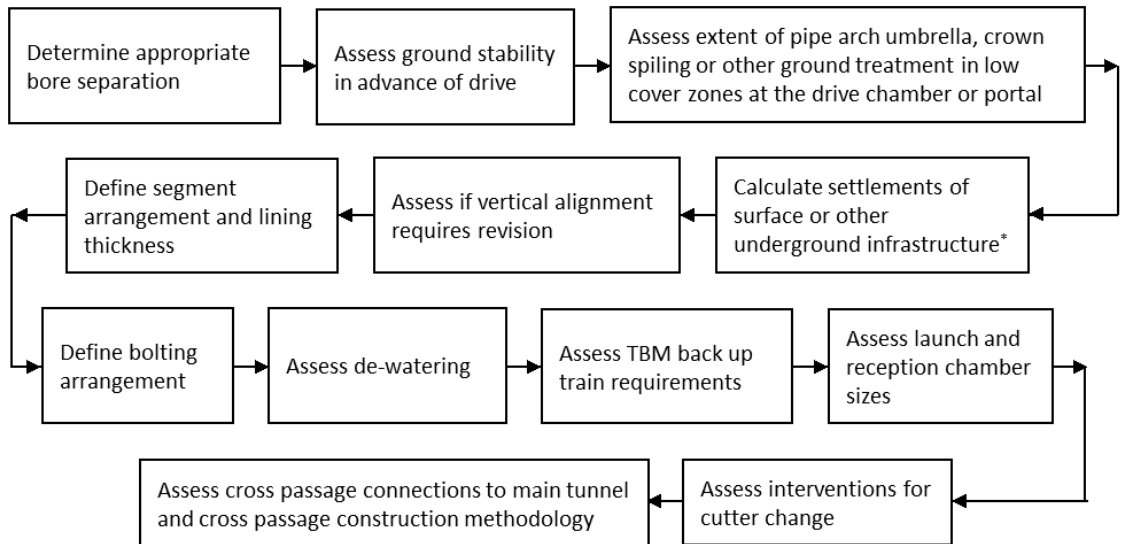

**Figure 2.30f Assessment of options to be applied to all tunnelling methods and tunnel structures**

**d. Assessment of options**

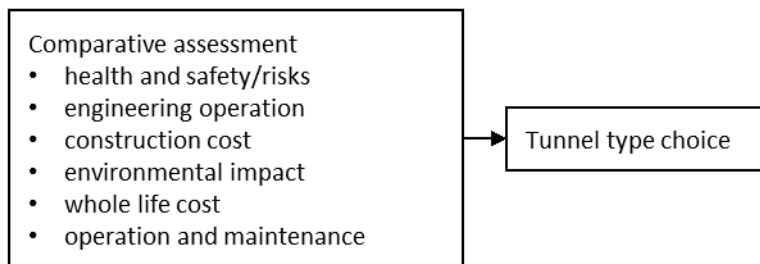

\*Based on volume loss of between 0.5% and 2.0% as appropriate to construction method and geology

### 3. Road tunnel safety

#### General

- 3.1 Operational safety facilities shall be provided in road tunnels to minimise risk to tunnel users and workers in normal day-to-day or emergency incident operating conditions.
- 3.2 Facilities to communicate with tunnel users in the event of disruptions to the normal traffic flow, such as maintenance, emergency incidents, lane/tunnel closures, diversions etc. shall be provided.
- 3.3 Illuminated escape signs shall be provided for use in addition to predefined tunnel operating procedures for responding to accidents, breakdowns or other emergencies and a means of closing the tunnel to traffic.

#### Tunnel safety facility provision

- 3.4 Facilities for operational safety shall be provided for each road tunnel according to its length, traffic conditions, the type of road involved (i.e. motorways or all-purpose trunk roads) and its importance with respect to the surrounding road network.
- 3.5 Information regarding the safe use of the tunnel by all users shall be developed and provided in a format agreed with the overseeing organisation.
- 3.6 Tunnel safety facility provisions shall be based on risk assessment of tunnel operational safety issues and required availability to traffic.

*NOTE 1 Section 2 Planning, safety and general design contains guidance on risk analysis and management.*

*NOTE 2 Factors contributing to the necessary level of tunnel safety provision include structural features affecting the tunnel layout and location, tunnel geometry, traffic loads and composition, communications, response to emergencies, including fire, emergency lighting and the role of mechanical ventilation (where provided) in the event of a fire.*

- 3.7 Road tunnel safety facilities shall be provided on the basis of risk assessment based on specific tunnel conditions and characteristics.

**Table 3.7 Typical safety provisions for each tunnel category**

Safety and fire prevention equipment		TUNNEL CATEGORY		
		AA/AB	C	D
Communication and alarm equipment	Emergency telephones	-	-	-
	Radio rebroadcast system	-	-	-
	Radio break-In system	x	x	x
	Public address system	-	x	x
	Vehicle/incident detection system	-	x	x
	General surveillance CCTV	-	x	x
Fire detection and extinguishing equipment	Automatic fire detection	-	x	x
	Portable fire extinguishers	-	-	-
	Pressurised fire hydrants	-	-	-
	Ventilation for smoke control	-	-	-
Lighting and signals	Normal lighting	-	-	-
	Emergency lighting	-	-	-
	Emergency exit signs	-	-	-
	Evacuation lighting	-	-	-
	Lane control and tunnel closure signs/signals	-	-	x
Stopping, turning and escape provisions	Emergency stopping lane	-	-	-
	Escape doors	-	-	-
	Turning bays	x	-	-
Drainage	Impounding sump	*	*	*
Where: (-)Typical safety provision. (x) If required by TOA. (*) Provision determined by local requirements.				

**NOTE 1** Table 3.7 provides a list of frequently used tunnel safety facilities and has been developed from PIARC publication "Classification of Tunnels, Existing Guidelines and Experiences, Recommendations, 1995 Ref[x.x].

**NOTE 2** Tunnel categories are described later in the Section.

3.7.1 Additional safety facilities may be required.

3.7.2 Separate criteria may apply to tunnels falling within the scope of the Road Tunnel Safety Regulations UKSI 2007/1520 [Ref 77.N] & The Road Tunnel Safety (Amendment) Regulations SI 2009 No 64, Annex B UKSI 2009/64 dup [Ref 60.N].

3.8 Each tunnel is to be addressed as a separate entity, and designs shall include the safety facility provision required for the specific characteristics of each individual tunnel.

**NOTE** At the stage when tunnel design and operational safety issues are being developed, a tabular presentation of facilities can provide a convenient starting point for the TDSCG to determine that

*systematic consideration is given to the specific safety issues at each site. It is also an effective means of conveying the key issues to non-specialists, particularly those employed in the general planning of projects that include tunnels, and provides a basis for establishing preliminary design requirements and cost estimates.*

- 3.9 Safety facility provisions shall be cost benefit assessed against available operational response to incidents, means of stopping traffic and closing lanes or tunnel bores; communications, surveillance, stand-by rapid response vehicle recovery facilities etc., and the consequence of traffic delays and pressure on the surrounding road network.
- 3.10 In matters relating to systems for communications and traffic control, the tunnel designs shall integrate with relevant systems already in place or planned on the surrounding network.
- 3.11 Finalised tunnel safety facility proposals shall be outlined within Approval in Principle documentation.
- 3.12 The design of safety facilities for each tunnel shall be based on the tunnel category derived from Figure 3.14.2 and the corresponding provisions given in Table 3.6.
- 3.13 The safety provisions given in Table 3.6 shall be developed and refined by risk assessments and consultation with the TDSCG and Emergency Services.
- 3.13.1 The risk assessment process should include ALARP decisions based on proportionate cost.
- 3.14 Tunnels shall be separated into categories AA, A, B, C, D and E according to length and AADT as shown in Figure 3.14.2.
- 3.15 Categories for AADT in excess of 100,000 vehicles per day shall be calculated by extrapolation of the Figure 3.14.2 graph.
- 3.15.1 Where the tunnel design year is not defined within the works information, it may be assumed to be 15 years from the date of tunnel opening.
- 3.15.2 AADT should be taken as the sum total of traffic in both directions through one tunnel bore.

Figure 3.15.2 Determination of tunnel category

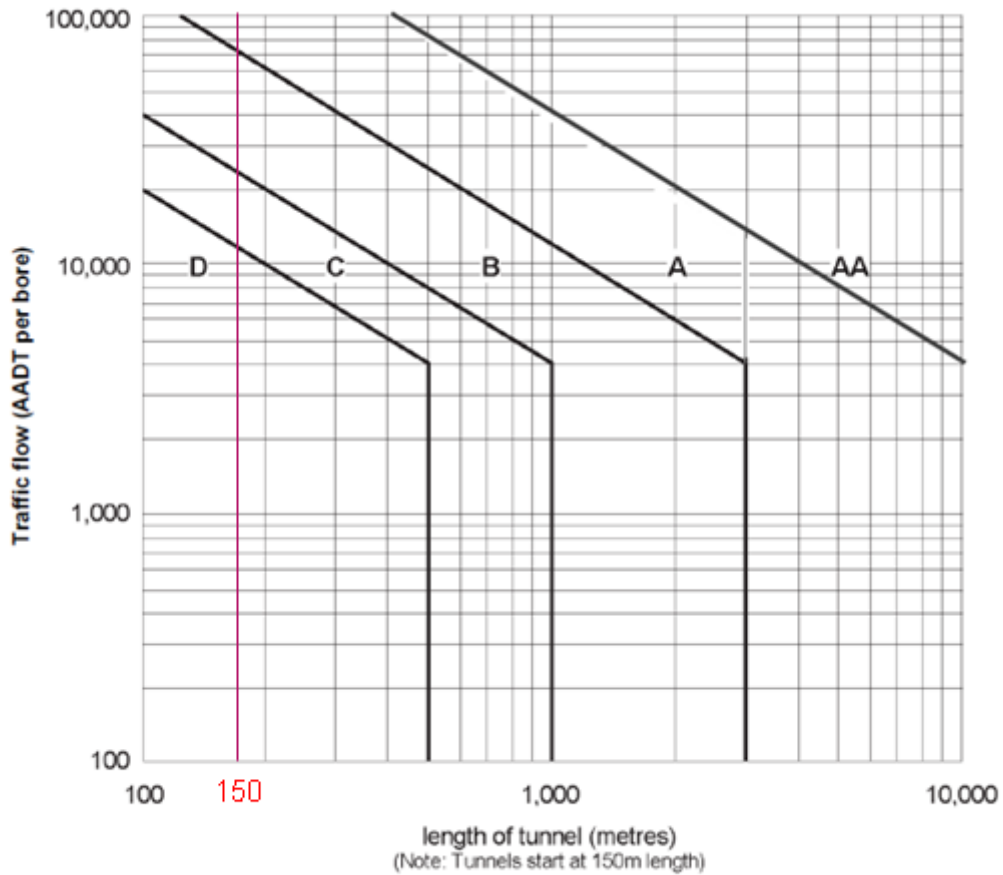

3.15.3 For the purposes of defining tunnel safety requirements, twin bore tunnels should be regarded as equivalent to two parallel single bore tunnels.

**Typical safety facilities, tunnel layout and structural features**

**General**

3.16 Provisions shall be included as outlined within this section if they are determined necessary for safe tunnel operation by operational risk assessment, emergency services or for compliance with the works information.

**Emergency panels**

3.17 Emergency panels (EP's) shall be provided at the tunnel portals, within lay-bys (if provided) and at 50m centres throughout the tunnel.

3.17.1 Supported by risk assessment, EP spacing may be extended to a maximum of 75m.

3.18 EP's shall be equipped with:

- 1) emergency roadside telephones;
- 2) portable fire extinguishers (in compliance with BS 5306-3 [Ref 30.N]).

3.19 Fire hose reels and fire hydrants shall be included in consultation with fire and rescue services.

3.20 Where hydrants are required for fire protection by FRS, they shall be provided at alternate EP's or as agreed with the TDSCG.

- 3.21 Where extended EP centres are proposed, hydrant locations at greater than 100m centres shall be subject to agreement with local fire and rescue services.
- 3.22 EP's shall be accommodated within the tunnel such that all tunnel users (including those with restricted mobility) can safely access and use them in compliance with the Equality Act UKPGA 2010/15 [Ref 24.N].

#### **Emergency stopping lanes**

- 3.23 Where provided, emergency stopping lanes shall be designed to allow stranded tunnel users safe access to emergency walkways and/or emergency panels as well as facilitating the safe removal of broken down vehicles by recovery services.

#### **Escape routes**

- 3.24 Safe means of emergency escape shall allow tunnel users to evacuate an affected tunnel bore safely in emergency incident conditions.
- 3.25 Emergency incident escape and incident access proposals for all design incidents shall be included within Approval in Principle documentation .
- 3.26 Emergency escape doors (cross-passages doors, inter-bore connecting emergency escape doors, door access to a dedicated emergency escape gallery, shall be located at intervals of up to 100m through the tunnel.
- 3.26.1 Emergency escape door intervals may be extended to a maximum interval of 150m where determined appropriate by a quantified risk analysis.
- 3.27 All emergency escape routes shall be equipped as described in Section 8.

*NOTE 1 Sections 2 and 8 contain additional guidance on tunnel fire safety provision.*

*NOTE 2 Section 4 contains additional guidance on tunnel emergency walkway provision.*

#### **Vehicle crossovers**

- 3.28 Vehicle crossovers on the approaches to twin bore tunnels to facilitate all tunnel operational and emergency service access shall be designed in compliance with CD 192 [Ref 74.N].

#### **Turning bays**

- 3.29 Where included, turning bays shall be sized to allow all permitted tunnel traffic and emergency services vehicles to turn around.
- 3.30 Where turning bays are proposed to be included, all designs shall be included in Approval in Principle documentation.

#### **Emergency services parking**

- 3.31 Where emergency services parking is determined as a requirement, designated rendezvous points for the marshalling of police and emergency vehicles and equipment when attending a tunnel incident, shall be included at one or more areas close to the tunnel portals.
- 3.32 Designated rendezvous point locations shall be conspicuously signed with a diagram 2712 'RVP' or 'FRP' sign in accordance with UKSI 2016/362 (TSRGD) [Ref 78.N].
- 3.32.1 Where required by emergency services, a premises information box should be provided.

#### **Drainage**

- 3.33 The design shall prevent standing water (or spilled liquid) accumulating on the road surface at any point through the tunnel.

3.34 Drainage sumps shall have sufficient volume and pumping capacity (where required) to address all expected ingress flow as outlined in Section 7.

3.35 Where a spillage impounding sump is to be provided it shall be sized and equipped as outlined in Section 7.

*NOTE Section 7 contains guidance on drainage sump requirements.*

#### **Detection of incidents**

3.36 Automatic tunnel monitoring systems shall alert tunnel operators to hazards, such as road traffic accidents, tunnel fire or spillage incidents, shed loads or debris on the carriageway, slow moving or stationary traffic, wrong direction traffic, presence of pedestrians, cyclists or animals within the tunnel etc.

*NOTE Automatic tunnel monitoring systems promote prompt implementation of incident response measures.*

3.37 General surveillance CCTV design shall include full coverage of all operational parts of the road tunnel and approaches, including emergency escape routes, in accordance with TD 131 [Ref 61.N].

### **Tunnel communications and emergency facilities**

#### **Communications**

3.38 Emergency roadside telephones (ERT's) shall be in accordance with TD 131 [Ref 61.N].

3.39 ERT's shall be intuitive to use and allow tunnel users to immediately communicate directly with the tunnel operators, police control centre or a central contact centre.

3.40 In-tunnel signage clearly signifying the locations of all emergency roadside telephones shall be provided.

*NOTE 1 Section 9 contains guidance on the provision of ERT's.*

*NOTE 2 UKSI 2016/362 (TSRGD) [Ref 78.N] outlines signage requirements.*

3.41 Equipment facilitating mobile phone usage within the tunnel environment shall be provided where determined by risk assessment and reasoning for non-provision is outlined within Approval in Principal documentation.

*NOTE Tunnel users can use personal mobile telephones to summon assistance in an emergency, in preference to the emergency roadside telephones.*

3.42 Radio re-broadcasting equipment shall facilitate emergency services and maintenance operators' in-tunnel communication.

3.43 Public address systems shall be capable of broadcasting live and recorded messages to the tunnel environment.

3.44 Public address systems shall be audible in all areas of the tunnel for all tunnel users and relevant installed systems under all operating conditions.

*NOTE Section 9 contains guidance on the design of Public address systems.*

3.45 Radio break-in systems shall inform, guide and assist tunnel users in tunnel incident conditions.

*NOTE Where radio break-in systems are to be installed, approval for use from UK communications regulator is required.*

#### **Traffic controls**

3.46 A comprehensive system of signs and signals shall be developed in consultation with the organisation with overall responsibility for authorising such installations on motorways and all-purpose trunk roads.

3.47 Traffic signs and signals shall be in compliance with UKSI 2016/362 (TSRGD) [Ref 78.N].

3.48 The tunnel traffic control systems shall be integrated with local networks and neighbouring traffic control systems.

#### **Tunnel emergency systems availability**

3.49 Facilities allowing the availability of systems, relating to emergency panels and tunnel emergency incident response, to be continuously monitored from the tunnel control centre, shall be included.

#### **Fire alarm & smoke control**

3.50 Facilities for raising an alarm, either by manual or automatic means, and responding to a fire shall be provided covering all areas of the tunnel, including the ancillary building(s).

3.51 Where an installed tunnel ventilation system is included, it shall provide air quality control in day-to-day and maintenance operation as well as to control the movement of smoke, hot gases, fumes etc. in tunnel emergency incident conditions.

*NOTE Facilities for controlling smoke by means of ventilation override and fixed fire-fighting systems (where relevant) are described in Sections 5 and 8 of this document.*

#### **Tunnel lighting**

3.52 Tunnel lighting shall be provided in compliance with the requirements outlined within Section 6.

#### **Mainspower failure and emergency lighting**

3.53 A secondary power source (mains or generator) shall be provided to allow the tunnel to continue operating safely in primary mains power failure conditions and in compliance with Section 11.

3.54 Uninterruptible power supply (UPS) shall have sufficient capacity and duration to power tunnel emergency lighting and all other systems required to permit safe evacuation and closure of the tunnel in the event of failure of the normal power supply.

3.55 Emergency tunnel lighting levels shall be in compliance with the requirements outlined within Section 11.

#### **Tunnel signs and signals**

3.56 Lane control signals and portal variable message signs shall be capable of notifying the closure of individual traffic lanes or full tunnel bore closures.

3.57 Where tunnel bore closures can be initiated, diversionary route signage shall be included on the tunnel approaches upstream of the relevant highway exits in compliance with UKSI 2016/362 (TSRGD) [Ref 78.N].

3.58 Illuminated signs on the road tunnel walls shall indicate in each direction the distance to the nearest emergency escape points of safety.

*NOTE Section 9 contains guidance on emergency exit signage.*

#### **Value engineering**

3.59 A value engineering exercise shall be undertaken to determine that all included safety equipment is required for the safe operation of the tunnel.

3.59.1 The assessment should be based on whether:

- 1) the investment represents a satisfactory balance between overall network safety, approach road safety and tunnel bore safety;
- 2) the safety objectives have been achieved in a manner representing the best value for money manner (allowing that prevention is more cost effective than post-incident management);

- 3) any measures provided for asset protection post-evacuation represent good value for money in the context of network disruption, repair costs and economic impact on the region, in the event of the asset becoming unavailable for a period of time.

## 4. Geometric design

### General

- 4.1 The geometric design of carriageways to include approach roads and the traffic space in relation to the structure within road tunnels, shall include the following:
- 1) ventilation (length and gradients);
  - 2) traffic movements (maintenance, emergencies);
  - 3) portals (provision for parking/turning emergency vehicles);
  - 4) operational safety (verge widths, lay-bys and long tunnels);
  - 5) traffic escort (marshalling facilities in portal areas);
  - 6) adjacent road network (disruption or queues due to tunnel closures);
  - 7) means of escape and emergency services intervention routes.
- 4.1.1 Design should make allowances for the special demands and conditions of approaching and driving through tunnels.
- 4.1.2 The initial geometric design of tunnels should be based on the design criteria and hourly traffic flows for comparable sections and classes of open road, to the physical characteristics of the tunnel profile and cross section, the design of the approach roads, the proximity of the tunnel portals to any surface junctions, the composition and speed of the traffic flow, construction costs, and the economic and safety benefits that ensue.
- 4.2 The required number of lanes shall be based on the capacity of the adjoining open road using TAG Unit A3 [Ref 81.N].
- 4.3 To limit distractions, the tunnel approach shall have the same geometric layout as the tunnel for a distance from the tunnel portal at least equal to the distance covered in 10 seconds by a vehicle travelling at the design speed.
- 4.4 The tunnel design speed shall be the same as the approach road design speed.
- 4.4.1 A relaxation of one design speed step may be used for determining Stopping Sight Distance (SSD) on approach and threshold zones where drivers are alerted by signing for a tunnel ahead.
- NOTE** *The zones are defined as:*
- 1) *approach zone: the length of approach road from the portal equal to 1.5 times the SSD;*
  - 2) *threshold zone: the length of tunnel from the portal equal to the SSD.*
- 4.5 Full Overtaking Sight Distance (FOSD) shall be verified as described in CD 109 [Ref 38.N].
- 4.6 The headroom used for checking SSD shall be either;
- 1) the maintained headroom plus the additional vertical clearance of 250mm as shown in Figures 4.12 and Table 4.12 in this document to give some protection to "soft" equipment, such as luminaires, from high vehicles carrying compressible loads or with loose ropes, flapping tarpaulins and similar that pass under the portal soffit; or
  - 2) the actual headroom less allowances for soffit-mounted equipment and resurfacing if this is greater.
- 4.6.1 Where the minimum SSD values are not achieved, either the tunnel headroom should be increased (which is not normally economical, particularly in bored tunnels), or the design speed and speed limit reduced.
- 4.6.2 Where the minimum SSD values are not achieved due to tight horizontal curved alignment, the tunnel may need to be made larger (which is not normally economical) or have a less horizontal curved road alignment and/or reduce the design speed.

4.7 Overtaking in a road tunnel, involving access to the lanes open to traffic travelling in the opposite direction shall not be permitted.

4.8 Gradients shall be limited to the open road desirable maximum gradients in CD 109 [Ref 38.N].

*NOTE For tunnels the penalties of steep gradients are more severe than on open roads and include higher ventilation costs, increased cleaning due to increased vehicle emissions including brake particulates and the buoyancy effect of hot smoke in the event of a fire. If the gradient/traffic flow and composition is sufficient to require a climbing lane the costs can be prohibitive.*

4.8.1 Where strategic alternative routes can be provided, it may be advantageous to prohibit heavy vehicles from steeply graded tunnels.

4.9 Carriageway crossfalls of 2.5% minimum shall be provided throughout the tunnel.

*NOTE 1 For tunnels, crossfall is required to drain water arising from routine wall washing, flushing away accidental spillage and any seepage.*

*NOTE 2 The provision of superelevation in a tunnel can have an adverse effect on the cross section and on the provision of service ducts under the road.*

4.9.1 The superelevation provides only small compensation for lateral acceleration and, if necessary, may be relaxed to the minimum crossfall of 2.5%.

4.9.2 Where a tunnel has a reverse curve it may not be possible to provide the minimum crossfall throughout (unless curvature is very large) to give drainage paths because of the combination of longitudinal gradients and crossfalls.

### **Tunnel cross section**

4.10 250mm additional clearances to those required by CD 109 [Ref 38.N], CD 127 [Ref 12.N] shall be provided to avoid damage to electrical, mechanical and communications operational equipment.

4.11 All equipment, including cabling, in a road tunnel shall be placed inside the areas for equipment and cladding shown in Figure 4.12.

4.12 In addition to the requirements shown in Figure 4.12 and Table 4.12, in deriving the minimum internal structural envelope, allowance shall be made for sight-lines, both SSD and visibility to signs and signals, equipment and construction tolerances, and verge width to reflect equality considerations.

**Figure 4.12 Tunnel cross sections**

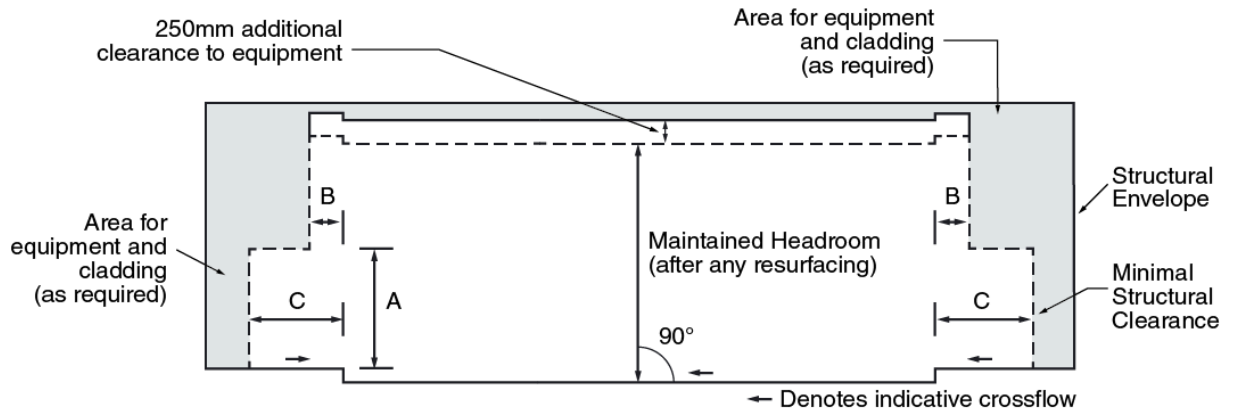

For dimensions A to C see Table 4.12

**Example Box profile**

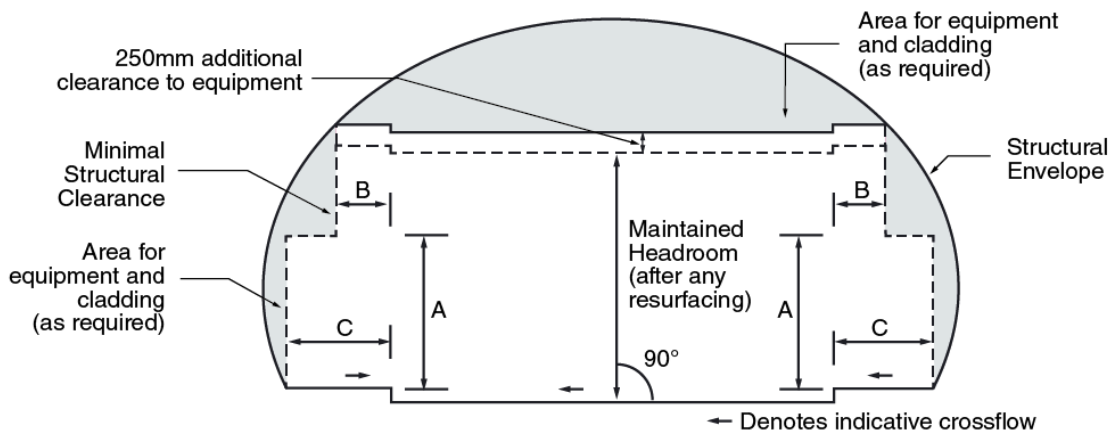

For dimensions A to C see Table 4.12

**Example Arch profile**

**Table 4.12 Minimum dimensions (See Figure 4.12)**

Dimension	Description	Box profile	Arch profile
A	Verge headroom	2300 mm	2300 mm
B	Width of verge with maintained headroom	600 mm	600 mm
C	Width of verge	1000 mm	1000 mm

4.13 In the design of verges reference shall be made to the guidance and recommendations in the Department for Transport publication Inclusive Mobility [Ref 40.N].

**Maintained headroom**

4.14 The maintained headroom, in Figure 4.12, shall be based on the same requirements of CD 127 [Ref 12.N], as for over-bridges on open roads.

4.14.1 The maintained headroom stated in CD 127 [Ref 12.N] may need to be compensated for on sag curves.

4.14.2 Any requirement to provide maintained headroom within structure free zones beyond the first 600mm of

the verges should be assessed based on the risk of damage to the structure and tunnel equipment.

- 4.14.3 The maintained headroom is the clearance to be preserved at all times. Any allowance for overlay should be based on a cost benefit analysis of overlaying rather than planing out and re-surfacing, including changes to kerb, verges, verge mounted equipment, doors and drainage inlets.

### **Traffic lane width**

- 4.15 Traffic lane widths in tunnels shall be in accordance with CD 127 [Ref 12.N].
- 4.15.1 The provision of carriageway hard strips or hard shoulders within a road tunnel should be subject to a cost benefit study based on the paved width of number of lanes, verge provisions and traffic flows, along with maintenance, operational and safety benefits.

### **Vehicle restraint systems**

- 4.16 Vehicle restraint systems requirements in tunnels and portals shall be assessed and specified in accordance with CD 377 [Ref 56.N].
- 4.16.1 A safety barrier leading to the tunnel portal should have the same alignment as the tunnel itself.
- 4.16.2 Where there is insufficient space to install safety fences and barriers at tunnel portals crash cushions (or similar devices) may be provided.
- 4.17 The lower 1500 mm of tunnel side walls shall be smooth, continuous and structurally resistant to impact from vehicles.
- 4.17.1 Finish to the roof of the tunnel should aid the installation of the fixings for the vent fans, lighting, cable trays etc.
- 4.17.2 Where verticality of the lower 1500 mm of wall is less than 5 degrees from vertical, then the walls can provide the same function as vertical concrete safety barriers, as used on the open road, and the provision of additional safety fencing may not be necessary.
- 4.17.3 At emergency cross passage doorways, open recesses, and other abrupt changes in cross section which present a hazard to traffic, the exposed edge should be chamfered horizontally, over a minimum height of 1500 mm, at an angle to the traffic direction, to mitigate to some extent the consequences of a vehicle impact.

**NOTE** *Doors or coverings can be designed to resist vehicle impacts.*

- 4.17.4 In the case of bi-directional tunnels, at cross passage openings, chamfered edges to the walls should be provided at both the approach and departure faces.

## 5. Ventilation requirements

### General

- 5.1 At the initial stages of design, an analysis shall be undertaken, to determine if tunnel user safety in day-to-day or emergency incident tunnel operation can be achieved by natural tunnel ventilation (a tunnel's natural geometric, traffic or environmental conditions) or if an installed tunnel ventilation system is required.
- 5.2 Where safe operation cannot be achieved by natural tunnel ventilation an installed mechanical tunnel ventilation system shall be included.

*NOTE Further information regarding ventilation system design fire magnitudes is outlined within Section 8.*

### Natural tunnel ventilation

- 5.3 Where it is proposed to use a natural tunnel ventilation strategy, the following shall be achieved for all external meteorological design conditions:
- 1) tunnel air quality and visibility is maintained at safe levels by means of traffic movement;
  - 2) tunnel users can evacuate the tunnel environment safely, in tunnel design fire incident conditions; and
  - 3) re-circulation of polluted air at portals is avoided (tunnel structural provision).
- 5.4 Tunnel created environmental conditions at the portals shall comply with EU 2008/50/EC [Ref 2.N].
- 5.4.1 APEA Guidance APEA Blue Book [Ref 2.I] should be considered.
- 5.5 For tunnel fire incident conditions in naturally ventilated road tunnels, analysis of the fire incident shall be undertaken to determine smoke stratification levels, duration of stratified layer stability and radiant heat from the smoke layer to the evacuation route below and that tenable conditions are maintained on the escape route(s) so that tunnel users can evacuate the affected bore safely.

### Mechanical tunnel ventilation

- 5.6 When determining which mechanical ventilation strategy to adopt, the following shall be taken into account:
- 1) structural implications for the tunnel created by the ventilation strategy and subsequent construction costs;
  - 2) ventilation system capital, installation, operating and maintenance costs;
  - 3) tunnel geometry & gradients;
  - 4) tunnel location & proximity to emergency services;
  - 5) potential tunnel fire incident location and magnitude;
  - 6) system monitoring & control;
  - 7) meteorological conditions at tunnel portals and ambient air movement through tunnels;
  - 8) emergency tunnel egress routes;
  - 9) traffic conditions and predicted vehicle emissions for opening year & design year;
  - 10) traffic operation (uni/bi-directional, tidal) / number of lanes;
  - 11) traffic density & speed of movement;
  - 12) traffic composition (type / age of vehicles), potential for hazardous loads;
  - 13) all pressure loss mechanisms (tunnel inlet, outlet, wall-shear, tunnel installed signage/cable trays/plant/instruments, shaft and plant room, vehicle blockage, vehicle drag etc.) including additional system resistance in tunnel fire conditions (fire plume drag, buoyancy loads, reduced density air effects, incomplete air mixing at the fire site, air temperature variation downstream of the incident site, tunnel obstruction created by the incident etc.);

- 14) other installed tunnel safety features;
  - 15) system noise levels within and adjacent to the tunnel environment / sound attenuation;
  - 16) environmental conditions at portals and ventilation shafts (including wind stagnation pressure at portals);
  - 17) contraflow option;
  - 18) types and proximity of neighbouring premises.
- 5.6.1 Regardless of the mechanical ventilation strategy adopted, the design should implement traffic-control procedures creating free-flowing traffic conditions.
- NOTE The self-ventilating effects of free flowing traffic through the tunnel can have operational cost benefits.*
- 5.7 The application of a longitudinal ventilation system in a bi-directionally operated road tunnel shall be justified by risk assessment.
- 5.8 The tunnel design fire magnitude and fire growth rate shall be determined by risk assessment.
- 5.9 The risk assessment shall include all applicable factors i.e. tunnel geometry, traffic usage (volume/composition/hazardous loads etc.), response times, safety provisions and available incident statistics etc. as well as incident likelihood, balanced against the consequences, such as economic costs, potential loss of life, risk of loss of tunnel structure and potential prolonged traffic disruption for repair works.
- NOTE Further guidance and requirements on vehicle fire loads are included in Section 8.*
- 5.10 The tunnel airflow rates required for all tunnel operating conditions (day-to-day traffic and contraflow/tidal-flow (where required), tunnel maintenance operations, tunnel design fire incident (or other tunnel emergency incidents at the worst case incident location), shall be determined.
- 5.11 The tunnel ventilation system shall be capable of achieving the determined duties for all tunnel and ventilation system operating conditions.
- 5.12 Where a tunnel ventilation system employing tunnel mounted jet fans is proposed, the design shall:
- 1) optimise separation between jet fan mounting locations (laterally and longitudinally) to maximise jet fan operating efficiency;
  - 2) prevent jet fan operating performance being impeded by signage or other tunnel equipment mounted upstream or downstream of the jet fan exit;
  - 3) include installation efficiencies relevant to the proposed mounting arrangement (soffit/wall separation, jet fan niches etc.);
  - 4) account for any throttling of the airflow due to proximity to soffit;
  - 5) include reverse operation jet fan thrust values (where different to forward operating thrust) for reverse jet fan operating conditions where required; and
  - 6) Include sufficient access for maintenance.
- 5.13 Where axial fans mounted outside the immediate tunnel environment are proposed, the installation arrangement (fans, ducting, dampers, louvres, sound attenuators etc.) shall minimise pressure losses through the system and maximise operating efficiency.
- 5.14 The tunnel ventilation design (in parallel with the structural design) shall minimise potential for re-circulation of exhausted pollutants/fumes/smoke/hot gases to the adjacent bore via either tunnel ventilation shafts, entry/exit portals or inter-connecting emergency escape routes, vehicular cross-connection.
- 5.15 Where tunnels are equipped with fixed fire fighting systems (FFFS), operation of either FFFS or tunnel ventilation systems shall not prevent ability of either systems from achieving its design duty.
- 5.16 The tunnel ventilation system shall be designed to address full design fire load conditions, regardless of the inclusion of a tunnel FFFS.

- NOTE** *Where a FFFS is proposed a specific risk assessment or experimental test results can be used to reduce the design fire load conditions in agreement with the Overseeing Organisation.*
- 5.17 To avoid adversely impacting evacuating tunnel users in incident conditions, the ventilation system shall not generate air-flows greater than 10m/s, averaged over time and across the tunnel width, in the lower 2m of the road tunnel, when operating at any of the proposed ventilation settings.
- 5.18 The design shall prescribe ventilation settings to be adopted by the operator for all operating conditions, design incidents and potential incident locations.
- 5.18.1 In tunnel fire incident conditions the prescribed emergency incident response setting should be implemented as quickly as possible in order to control the movement of smoke and hot gases and maximise tunnel tenability for evacuating tunnel users and emergency service responders accessing the incident.
- 5.18.2 At tunnels with manned monitoring facilities, the prescribed ventilation response settings should be available, to the tunnel monitors.
- NOTE** *It is typically the tunnel monitoring operative's responsibility to activate the relevant incident ventilation setting in response to any emergency incident condition encountered and to adjust ventilation settings at the request of responding emergency services.*

### **Smoke control panels**

- 5.19 Where determined as necessary following consultation with local fire and rescue services, smoke control panels (SCP) shall be provided outside the tunnel portals from where attending fire and rescue service personnel can take over manual control of the tunnel ventilation system.
- NOTE** *Further information regarding SCP provision and requirements are included in Section 8.*

### **Enclosed escape routes and cross-passages**

- 5.20 Enclosed escape routes (isolated from the tunnel bores) shall be designed to protect against the ingress of smoke or fumes from any incident within a connected tunnel bore.
- 5.20.1 Enclosed escape routes ventilation air may be drawn from the non-incident bore of a twin bore tunnel, provided that any risk of re-circulation of smoke or fumes into that bore has been reduced to an acceptably low level.
- 5.21 In cases where a dedicated emergency escape corridor is being ventilated with air from outside the tunnel via air ducts, the external air shall be sourced from a location that is not contaminated with smoke or fumes being exhausted from the incident bore.
- 5.22 Pressurised elements of emergency escape routes shall facilitate use by evacuees such that:
- a) the force to open an emergency door does not exceed the recommendations of BS EN 12217 [Ref 17.N]; and
  - b) air velocity in an escape route or cross-passage does not exceed 10 m/s up to 2m above floor level.

### **Day-to-day tunnel airflow requirements: calculation method**

- 5.23 Design traffic data (traffic composition, percentage heavy goods vehicles in different weight bands etc.) shall be determined from available traffic data or by prediction based upon the road type, location and surrounding industry etc.
- NOTE** *Up to date UK traffic composition data is available from the Department of Environment, Food & Rural Affairs (DEFRA).*
- 5.24 In determining the ventilation capacity necessary to maintain acceptable air quality standards within the road tunnel, the calculation methodology, pollutant design values and vehicle emissions factors (including non-exhaust particles) outlined within Vehicle Emissions and Air Demand for Ventilation PIARC R05 [Ref 50.N] shall be employed.

- NOTE 1** *PIARC Vehicle Emissions and Air Demand for Ventilation PIARC R05 [Ref 50.N] includes emission data for CO, NOX, and particulate matter including correction factors to reflect the influence of cold start and altitude. Guidance on the relationship between NOX and NO<sub>2</sub> is also given as are extinction coefficients for use in ventilation system design.*
- NOTE 2** *It is assumed that adequate dilution for unregulated pollutants can be provided for by ventilation system control which relates to regulated pollutants.*
- 5.25 Ambient external air quality levels shall be taken into account when assessing in-tunnel pollution levels and calculating tunnel airflows to be generated by the ventilation system.
- 5.26 Tunnel ventilation airflow requirements shall be designed for worst-case congested traffic and for free-flowing traffic conditions.
- 5.26.1 Airflow calculations should be undertaken for traffic speeds 0 km/h, 5 km/h and 10 km/h and, thereafter, speeds increasing in steps of 10 km/h up to the design speed limit to allow the maximum tunnel ventilation airflow duty and the worst-case tunnel portal and/or shaft emissions to be determined.

### **Tunnel fire incident ventilation design**

- 5.27 Where a longitudinal tunnel ventilation system is proposed, the required air velocity necessary to control the movement of smoke and hot gases in a design fire magnitude incident, such that a clear air environment is maintained on the upstream side of the incident site, shall be determined by computational simulation or by calculation.
- 5.28 The tunnel ventilation system shall be capable of achieving the required emergency ventilation duty for a design fire magnitude incident occurring at the worst case location within the tunnel (in terms of required ventilation thrust), allowing for the maximum potential in-tunnel vehicle density and adverse portal pressures (due to meteorological effects).
- 5.28.1 In determining the ventilation system requirements for the fire incident condition, the design calculations should include allowance for the following:
- 1) performance loss of fans operating in elevated temperature environment;
  - 2) fans unavailable due to routine maintenance;
  - 3) any fan(s) being unavailable for service due to fire proximity / fire damage/; and
  - 4) additional resistances to the ventilation system created by the fire incident e.g. fire plume drag, buoyancy loads, incomplete air mixing at the fire site, tunnel air velocity variations associated with air temperature variations downstream of the incident site (heat loss to the structure) and potential tunnel obstruction created by the incident.
- 5.29 Where longitudinal ventilation is used in bi-directional traffic conditions, potential incidents shall be planned for in advance and ventilation responses for each situation determined and outlined within the design.
- NOTE** *It might be the case that in bi-directional traffic, or congested tunnel traffic conditions, the most appropriate response is not to activate the ventilation system, for instances where analysis has determined that buoyant smoke layers can remain stable for a sufficient duration to allow safe evacuation by tunnel users passing below the smoke layer.*

### **Exposure limits for staff in tunnels**

- 5.30 The tunnel ventilation system setting which tunnel operators activate to maintain acceptable air quality standards for tunnel maintainers, contractors or other parties undertaking work within the tunnel environment shall be determined within the design.
- 5.31 Exposure limits for CO<sub>2</sub>, NO<sub>2</sub>, NO and particulates (ppm10 & ppm2.5) for maintenance staff and non-motorised users must be in compliance with HSE EH40 [Ref 86.N] and in EU Legislation 2017/164/EU [Ref 1.N].

### **Air quality monitoring and ventilation control**

- 5.32 All tunnel sensors and ventilation monitoring/control systems shall be compliant with the IEEE IEEE C37.1 [Ref 69.N].
- 5.33 All tunnel sensors and ventilation monitoring/control systems shall use non-proprietary or open source communications protocols.
- NOTE* *Guidance on SCADA systems and requirements are included in Section 10.*
- 5.34 The control system employed shall provide efficient ventilation operation and safeguard the installed fans from frequent switching.
- 5.35 Tunnel air quality (CO, NO, NO<sub>2</sub> etc.), visibility and air velocity monitoring instruments shall be provided within the tunnel and located such that a realistic measure of conditions throughout the tunnel can be recorded.
- 5.36 The installed monitoring instrumentation shall be provided in duty/stand-by arrangement at each location.
- 5.37 All monitoring instrumentation shall be located to be safely and readily accessible for the purposes of inspection, maintenance and replacement.
- 5.37.1 It should not be necessary to remove other equipment to access or remove the monitoring instrumentation.
- 5.38 The monitoring instruments, their enclosures and mountings shall be designed for operation within the road tunnel environment, enduring the tunnel atmospheric conditions and maintenance activities, such as tunnel washing operations, for a minimum of 20 years.
- 5.39 Ingress protection rating for the monitoring instruments shall be minimum IP66.
- 5.40 In day-to-day tunnel operation the ventilation system shall operate automatically, in the most efficient and effective way, in response to signals from the installed instruments.
- 5.41 Air quality within the tunnel and its surroundings shall be maintained within the exposure limits set by UK CAS 2019 [Ref 6.N] and EU ( 2008/50/EC [Ref 2.N]).
- 5.42 Where installed monitoring systems detect incident conditions such as a tunnel fire or spillage, or air quality/visibility levels deteriorating toward tunnel closure levels, an alert shall to be raised at the tunnel monitoring facility/control centre so incident response plans can be initiated rapidly.

### **Acceptable tunnel air quality (interior)**

- 5.43 In day-to-day operation the installed tunnel ventilation system shall be capable of maintaining a safe tunnel atmosphere for tunnel users.
- 5.44 Allowable pollutant and particulate concentration limits shall be determined based upon the most recent published data on their effects on humans and acceptable exposure limits.
- 5.45 The proposed values and the methodology by which the allowable pollutant and particulate concentration limits have been determined shall be outlined within Approval in Principle documentation.
- NOTE 1* *The following limiting pollutant and particulate (visibility) concentration values, summarised in Tables 5.45N1 & 5.45N2, are provided for guidance. The outlined values have been determined based upon review of relevant documents PIARC R05EN PIARC R05 [Ref 50.N], HSE HSE EH40 [Ref 86.N], BTS best practice guide NO: Best Practice Guide [Ref 14.I], Mott MacDonald Report 5 HSE NOX [Ref 9.I] and TRL's Report 1 TRL UPR/IE/31/06 [Ref 7.I].*

**Table 5.45N1a CO, NO and NO2 limits for road users within a tunnel**

Pollutant	Tunnel user exposure	Tunnel sensor limit	Workplace exposure limit
CO (Carbon monoxide) conservative values	Short-term limits: fifteen minutes, or less, average exposure	A: 100 ppm B: 50 ppm C: 35 ppm	100 ppm
NO (Nitric oxide)	Short-term limits: fifteen minutes, or less, average exposure	A: 37.5 ppm B: 18.8 ppm C: 7.5 ppm	15 ppm (not mandatory – for guidance only as not considered critical)
NO <sub>2</sub> (Nitrogen dioxide)	Short-term limits: fifteen minutes, or less, average exposure	A: 7.5 ppm B: 3.8 ppm C: 1.5 ppm	1 ppm
Where: 1) A = tunnels up to 500m in length, 2) B = tunnels between 500m and 1,000m in length, 3) C = tunnels between 1,000m and 2,500m in length.			

**Table 5.45N1b Visibility limits (haze from vehicle fumes, particulate matter etc.)**

Application	K - "Visibility Loss" at peak traffic (m-1)	
Fluid traffic	V <sub>max</sub> = 60 - 80 km/h	≤ 0.007
	V <sub>max</sub> ≥ 80 - 100 km/h	≤ 0.005
Congested traffic	≤ 0.009	
Tunnel to be closed	≥ 0.012	
Maintenance work, with tunnel traffic	≤ 0.003	
Where: 1) V = traffic speed, 2) K = extinction coefficient.		

**NOTE 2** Workplace exposure limits (WELs) are set with thresholds below which, on existing knowledge, there are thought to be no adverse effects on people. In the absence of more specific scientific data, the values have been conservatively adapted for road users within tunnels.

**NOTE 3** The tunnel sensor limit values allow for pollution concentration for in-vehicle tunnel users and time of exposure with respect to length of tunnel for congested traffic travelling at 10 km/h.

**NOTE 4** Table 5.45N1a includes allowance for in-vehicle exposure rather than tunnel roadside exposure. Supporting information is available in TRL's report 'Impact of Revised HSE NOX Standards on Road

*Tunnels TRL UPR/IE/113/07 [Ref 8.I] and TRL's Road Tunnel Air Pollution Monitoring TRL PR/SE/746/03 [Ref 15.I].*

- 5.46 Signals from the tunnel sensors shall be capable of automatically activating the installed tunnel ventilation system (where provided) in stages before measured pollution levels reach the limiting levels for any of monitored pollutants.

*NOTE Tunnel closure procedures are typically implemented if concentrations of any monitored pollutant breaches its maximum limiting level.*

## **External environmental conditions**

### **Meteorological**

- 5.47 The tunnel ventilation system shall deliver the required performance (within the tunnel and externally) for all operational settings when subjected to the worst combinations of design meteorological conditions i.e. wind speed & direction, humidity and extremes of temperature recorded for that area.
- 5.48 Meteorological conditions used in the tunnel ventilation system design shall be based on historic meteorological records for the tunnel site with an additional allowance for climate change projections applicable to the local area.
- 5.49 Sensors monitoring external ambient wind speed and direction shall be located at each of the tunnel portals and at any ventilation shafts.

### **Effects on ambient air quality**

- 5.50 Ambient air quality records for the tunnel site area shall be obtained at design stage and used in the tunnel air quality and portal emissions calculations as well as any subsequent assessment of the impact the operating tunnel ventilation system has had on its local environment.
- 5.51 Where existing ambient air quality records are not available an air quality survey in the area local to the tunnel site shall be commissioned.
- 5.52 The predicted effects of tunnel vehicle emissions being exhausted to the atmosphere at tunnel portals or exhaust shafts on the external ambient conditions and on buildings in the locality shall be analysed.
- 5.53 Polluted air being exhausted at tunnel exhaust shafts or portals must be compliant with the requirements of the EU Ambient Air Quality Directive 2008/50/EC [Ref 2.N] and the DEFRA Clean Air Strategy CAS 2019 [Ref 6.N].
- 5.54 Where it is found that operating the tunnel creates external air quality conditions in breach of legislative requirements at the portals or shafts, an alternative means of exhausting the polluted tunnel air shall be employed.
- 5.54.1 Where portal emissions have to be limited, the inclusion of ventilation shafts exhausting polluted tunnel air at high level can aid dilution and dispersal. High level shafts, subject to any planning consent, may be located either close to the portals or at intermediate locations along the length of the tunnel, depending on the form of ventilation adopted.
- 5.54.2 The visual impact of tunnel ventilation shafts on the local environment should contribute to determining suitable shaft locations.
- 5.54.3 As air supplied by tunnel ventilation systems is sourced from the external environment, the quality of the air supplied to the tunnel has a significant bearing on the quality of the air being exhausted to the environment at tunnel portals or ventilation shafts, in day-to-day tunnel operating conditions. Where ambient air quality records, or air quality survey results, show that the ambient air quality in the locality of the road tunnel is not within acceptable standards, it can be impossible to comply with ambient air quality standards in the vicinity of where the tunnel air is being exhausted. In such circumstances the issues should be highlighted and a proposed solution to be used in the tunnel design outlined within Approval in Principle documentation.

## Ventilation system safeguards and system reliability

### Reliability

- 5.55 The tunnel ventilation system design shall include provision such that:
- 1) the tunnel ventilation duty can be achieved (and tunnel users protected) in the event of a single failure of any individual system components, including installed fans and associated plant, power supplies and power cables as well as all monitoring and control system cables & equipment;
  - 2) the ventilation system can continue to maintain tunnel air quality within the limits specified in the event of a single grid supplied mains power supply failure; and
  - 3) maintenance work, both planned and unforeseen, is facilitated and disruptions to tunnel traffic flow for maintenance activities are kept to a minimum.
- 5.55.1 Alternate fans should be powered from separate power sources such that in the event of a failure of an individual supply, the fans connected to the healthy supply can remain operational.

### Jet fan redundancy

- 5.56 Jet fan redundancy shall be included within the ventilation design allowing for:
- 1) normal operation: jet fan unavailability due to routine maintenance or occasional failure; and
  - 2) tunnel fire incident: in addition to normal operation redundancy requirements, jet fans located close to the fire site unavailability due to temperature effects/fire damage (where calculated tunnel air temperatures are in excess of the fire rating of installed jet fans).
- 5.56.1 For design purposes the following redundancy levels may be used as indicative:
- 1) normal operation: 2 fans or 10% of the fans (to the next whole number), whichever is the greater; and
  - 2) tunnel fire conditions: jet fan unavailability due to fire incident proximity (where tunnel air temperatures exceed jet fan fire rating) can be calculated using the following, where X = distance in metres, M = fire magnitude in MW:
    - a) Upstream:  $X = (-0.0017M^2) + (0.45M) + 1.667$
    - b) Downstream:  $X = (-0.0067M^2) + (1.8M) + 6.667$

### Axial fan / centrifugal fan redundancy:

- 5.57 Ventilation designs involving axial or centrifugal fans mounted outside the tunnel environment shall include fan redundancy to allow for fan unavailability due to routine maintenance or occasional failure in normal operation.
- 5.58 Fans shall be installed in a duty/standby arrangement such that switching from one fan to another occurs automatically.
- NOTE Where more than one fan serves a particular duty, only one standby unit need be provided.*

## Ventilation fans

### Fan motors

- 5.59 Efficiency classes for fan motors (with conventional starters or with variable speed drives) must be in accordance with BS EN 60034-30-1 [Ref 62.N] and EC/640/2009 [Ref 19.N].

### Axial fans

- 5.60 Axial fan motors and motor components (switching, gearbox drives etc.) shall be mounted so that individual components are accessible for inspection and maintenance.
- 5.61 The fan design shall incorporate fan stall control measures for all fan duty settings.

**NOTE** *Axial flow fans, with high pitch angles, can suffer an aerodynamic stall characteristic which occurs at low flow/high pressure conditions.*

5.62 Axial fans shall normally be operated at their point of maximum efficiency.

#### **Jet fans**

5.63 Jet fans shall be provided with fail safe anti-vibration mountings to prevent the fans falling onto traffic in the event of the failure of a fixing.

5.63.1 Provision of safety chains, as secondary fastenings at jet fan mounting points, may be employed to prevent falling following primary mounting failure.

5.64 Vibration monitoring shall be provided for all installed jet fans and an alarm raised via SCADA when the recorded vibration exceeds manufacturer defined thresholds.

5.65 Motor winding temperature monitoring shall be included with a temperature sensor in each winding and an alarm raised at the monitoring location when the recorded temperature exceeds manufacturer defined thresholds.

5.66 Temperature and vibration monitoring shall be provided for each bearing (i.e. at each end of the motor) and an alarm raised at the monitoring location when the recorded temperature exceeds manufacturer defined thresholds.

5.67 Where motors are driven by soft starters or variable speed drivers, insulated bearings shall be provided.

5.68 To facilitate motors to be replaced for maintenance purposes, IP65 rated socket arrangement shall be included for each sensor and electrical supply to the fan.

5.69 The design of jet fan ventilation systems shall include the design of a mobile jet fan cradle arrangement allowing prompt jet fan/motor removal and installation.

5.70 Design materials shall be selected to avoid galvanic and other corrosion of any jet fan fixings.

5.71 Provision shall be included for any water entering a jet fan (during washing activities etc.) to drain out.

#### **Fan reversibility**

5.72 Where the normal tunnel operation design ventilation settings include reversal of tunnel airflow for any design operating condition, truly reversible (delivering the same fan thrust in either direction) jet fans shall be provided.

5.73 Where tunnel airflow reversal is an infrequent (exceptional circumstance) operating requirement, the use of standard jet fans operating in the reverse to normal direction shall be permitted if the required ventilation duty can be achieved with the reduced jet fan thrust performance available in the reverse operation mode.

5.74 Where large axial fans mounted in shafts are required to operate in the reverse to normal direction of operation, the axial fan shall be capable of delivering at least 70% of the normal direction airflow while operating in the reverse direction.

5.75 The ventilation control system design shall include tolerances such that fan reversals are kept to a minimum.

#### **Fan speed and reversal control**

5.76 Fans starters shall be selected and starting sequences designed to reduce starting currents and peak load demand on the power supply.

5.77 Multiple fans shall not be controlled from one starter, however groups of fans connected to a single control panel with individual switches to dedicated fan motor starters is permissible.

5.78 Where jet fan reversibility is required, motors shall be capable of undertaking 10 starts per hour, in either direction, with up to 1 start and 2 reversals in a minimum of 10 minutes.

- 5.79 Variable speed motor control shall be used to control fan output, rather than blade angle variation.
- 5.79.1 Where variable speed control by frequency converter is proposed, gearing should be matched with motor thermal characteristics and the control circuits to maximise the power factor.

#### **Fire rating of fans**

- 5.80 All fans as well as electrical, monitoring, control and structural components essential to the continued operation of ventilation fans (with potential exposure to elevated air temperatures in fire incident conditions) shall be capable of operating in smoke-laden air at a temperature of 250°C for 2 hours.
- 5.81 Tunnel fans shall be in accordance with part 3 of BS EN 12101-3 [Ref 66.N].

#### **Noise levels**

- 5.82 Ventilation system noise levels in a tunnel (including escape routes), particularly at times of emergency fan use, shall not interfere with the use of emergency communication systems and public address / voice alarm (PA/VA) audibility (where included).

*NOTE The design maximum noise level value is a primary requirement for PA/VA design.*

- 5.83 The maximum tunnel noise levels generated by the operating ventilation system must not expose tunnel users, maintainers/contractors or emergency incident responders to noise levels greater than acceptable within 'The Control of noise at work regulations' UKSI 2005/1643 [Ref 72.N].
- 5.84 The maximum noise level permissible in the tunnel environment with the ventilation system operating at its maximum setting, shall be determined by calculations.
- 5.85 The design shall include noise attenuation plant such that the calculated permissible maximum noise level is not breached for any operating condition.
- 5.85.1 A maximum permissible level of NR85 at any point in a plane 1.5m above the road surface has been a long accepted UK road tunnel requirement and may be adopted as a noise level requirement where it is in compliance with the relevant HSE control of noise regulations.
- 5.86 All required regulatory internal (tunnel and associated buildings) and external noise level impact assessments shall be undertaken as part of the design.
- 5.87 Fan buildings, ventilation shafts, extract fan outlets and ventilation plant, shall be located to minimise the impact of any fan noise breakout on local inhabitants or the general public.
- 5.88 The ambient noise levels must comply with environmental noise regulations and environmental protection regulations.

*NOTE The control of noise to the outside environment can depend on individual circumstances and the area background noise levels during fan operation. Where external ventilation building(s) are proposed, BS 7445-1 [Ref 15.N] and BS 8233 [Ref 37.N] provide guidance on noise reduction and sound insulation for buildings.*

#### **Tunnel ventilation design report**

- 5.89 The tunnel ventilation design shall include production of a detailed design report that can be reviewed where changing circumstances necessitate a review of the capabilities of a tunnel ventilation system after the initial design was carried out.
- 5.90 The tunnel ventilation design report, outlining the basis of design, methodology, modelling strategy, interpretation of results and sensitivity of results to key assumptions and simplifications, shall be appended to the operational and maintenance documentation.
- 5.91 Where a tunnel ventilation design employed computational and fluid dynamics software, a description of the modelling strategy shall include details of the computational mesh, boundary conditions, turbulence and heat transfer modelling assumptions, and the representation of the fire including the yield of soot and the toxicity of the products of combustion.

## 6. Lighting design

### General

- 6.1 Tunnel lighting shall be designed to BS 5489-2 [Ref 10.N].
- 6.1.1 Values for performance variables such as correlated colour temperature, which are given latitude within BS 5489-2 [Ref 10.N], should be proposed in the AIP.
- 6.2 Tunnel lighting shall be compliant for contraflow operation in a normally one-way bore when it is foreseen that this is necessary for maintenance activities or incident management.
- 6.3 The speed restriction that is to apply during contraflow operation shall be recorded in the operation and maintenance manual.
- 6.4 The design of external lighting on tunnel approaches shall be in accordance with BS 5489-1 [Ref 9.N] and TD 501 [Ref 58.N].
- 6.4.1 The lighting solution should reduce the overall energy consumption of daytime lighting through design and/or specification of:
- 1) all elements that directly affect access zone luminance;
  - 2) road surfacing and other surface finishes within the tunnel; and
  - 3) tunnel operation and maintenance procedures.
- NOTE 1 The quantity of installed lighting equipment and its energy consumption through its life is affected by several tunnel design choices, as described in Annex A of BS 5489-2 [Ref 10.N].*
- NOTE 2 BS 5489-2 [Ref 10.N] divides emergency lighting into two parts - 'standby lighting' and 'evacuation lighting' as follows*
- 1) *Standby lighting provides visibility for tunnel users to evacuate the tunnel in their vehicles in the event of failure of the power supply;*
  - 2) *Evacuation lighting is provided to guide tunnels users to evacuate the tunnel on foot after leaving their vehicles in emergency circumstances such as fire.*
- NOTE 3 Guidance for the design of evacuation lighting is address in Section 8.*
- 6.5 Counter-beam lighting shall not be used unless a documented risk assessment shows that all possible risks are as low as reasonably practicable (ALARP).
- 6.6 Light sources, control gear/drivers, optics, lighting arrangement and control/monitoring system shall be selected to optimise the following features to minimise whole life cost, environmental impact and/or operational impact:
- 1) optimum combination of switching and/or dimming individual luminaires;
  - 2) maintenance factor compensation;
  - 3) maximum energy efficiency;
  - 4) maximum life;
  - 5) lumen depreciation;
  - 6) cleaning requirements;
  - 7) instant restrike;
  - 8) compatibility with other tunnel systems;
  - 9) accessibility and ease of maintenance;
  - 10) disruption to tunnel operation for routine maintenance activities.
- 6.7 Daylight louvre or screen structures over the tunnel entrance shall not be installed unless a thorough, documented risk assessment shows that:

- 1) there is a significant whole life costs benefit;
- 2) there are no significant dis-benefits, such as difficult or frequent maintenance, problems due to extreme weather, especially accumulation of snow and ice, and impairment of tunnel ventilation performance.

6.8 The assessment of visual discomfort due to flicker frequency shall be in accordance with BS 5489-2 [Ref 10.N] over the range of expected traffic speeds.

6.9 The initial lighting design calculations shall use an overall lighting design maintenance factor of 0.70.

**NOTE** *Longer intervals between cleaning of luminaires and/or re-lamping can mean that more lighting is needed and energy consumption can be higher. It is important to agree the tunnel maintenance regime so that the optimum balance can be found between maintenance intervention (including tunnel washing), capital and operational (energy) costs.*

6.9.1 The initial overall lighting design maintenance factor of 0.70 should be refined once the data is available for a more accurate maintenance factor to be calculated.

6.9.2 Checks should be made on the performance of the tunnel lighting and the build-up of dirt on luminaires and tunnel surfaces.

6.9.3 The operation and maintenance manual should set out in detail what maintenance checks the tunnel lighting requires and at what time interval.

### **Standby lighting**

6.10 Standby lighting, for in the event of a power failure, shall be designed to BS 5489-2 [Ref 10.N] , BS EN 50172, BS 5266-8 [Ref 21.N].

6.10.1 Incorporation into the standby lighting design of an automatic standby lighting testing system may minimise the maintenance requirements and number of road / lane closures required to carry out the testing regimes outlined in BS EN 50172, BS 5266-8 [Ref 21.N].

6.10.2 The standby lighting design may utilise the interior zone lighting system for the purpose of providing standby lighting.

6.11 Standby lighting shall be supplied from an uninterruptible power supply (UPS) system.

6.12 The standby lighting UPS system shall have a two-hour battery autonomy at full-load.

**NOTE** *Section 11 contains requirements and guidance on the design of UPS systems.*

6.13 Where the interior zone lighting system is utilised to achieve the required standby lighting illuminance levels, standby lighting circuits shall be controlled to achieve the night-time illuminance levels.

6.13.1 Where a safety integrity level (SIL) has been defined for the standby lighting, the design of the lighting control system should be in accordance with BS EN 61508-2 [Ref 35.N].

### **Tunnel lighting luminaires**

6.14 Luminaires shall be in accordance with BS EN 60598 (All parts) [Ref 46.N].

6.15 Luminaires shall have proven corrosion protection against the combined effects of vehicle pollution, dust and chemicals used in tunnel cleansing, together with road salts thrown up by traffic turbulence.

6.15.1 To minimise the risk of corrosion, luminaires and their associated supports and fixings should be designed to be self-draining to avoid the accumulation of moisture to eliminate direct contact between dissimilar metals.

6.16 All luminaire glazing in the tunnel shall be of the same type of glass, to prevent future maintenance errors.

6.16.1 Where toughened glass is required for some luminaires (for example to withstand elevated operating temperatures), all tunnel lighting should be fitted with toughened glass to eliminate the risk of incorrect replacement.

- 6.16.2 An impact rating of at least IK09 should be used, in accordance with BS EN 62262 [Ref 13.N].
- 6.17 Where discharge lamps are used they shall incorporate electronic control gear designed to switch off in the event that the lamp does not function properly, to avoid lamp recycling and the risk of permanent damage to the control gear.
- 6.18 Luminaires shall be designed to eliminate photobiological risks in normal use and during maintenance activities.
- NOTE** *Installations employing high-efficiency LEDs with enhanced levels of light towards the blue end of the visible spectrum can be particularly damaging to eyesight.*

### Location of luminaires

- 6.19 Luminaires shall be located so as to permit unobstructed access for cleaning, re-lamping and replacement.
- 6.19.1 The selected location can have a significant impact on light distribution within the tunnel and should be determined at an early stage.
- NOTE 1** *For many two-lane tunnel interior zones a single central line of luminaires can provide the required luminance. This is the most efficient means of lighting the carriageway evenly. However, access to luminaires can require complete closure of the tunnel bore since both lanes will be obstructed.*
- NOTE 2** *Mounting luminaires on either side of the carriageway offers the possibility of maintenance access, if safety considerations permit, to one row of lighting whilst, permitting traffic flow in the remaining lanes.*

### Environmental conditions

- 6.20 All luminaire and equipment enclosures, support steelwork and fixings within the tunnel environment shall be designed to meet category C5 of BS EN ISO 9223 [Ref 11.N] for the design life given.
- 6.21 All equipment, fittings and any other components of the permanent installation within the tunnel and linked areas affected by the tunnel environment shall have an ingress protection rating of at least IP66, as defined in BS EN 60529 [Ref 14.N].
- 6.22 Luminaires shall have been tested to withstand the potential water jet velocities expected within the tunnel environment. These velocities may be greater than those specified in BS EN 60529 [Ref 14.N].

### Road surface reflectance

- 6.23 The average luminance of the tunnel walls up to a height of 2m shall be in accordance with BS 5489-2 [Ref 10.N].
- NOTE 1** *The quality of the reflective interior wall or lining finishes together with the lighting design performance strongly influence drivers' comfort, safety and sense of well-being when passing through a tunnel.*
- NOTE 2** *The choice of wall finish can depend on the form of tunnel construction. It can range from plain concrete with an applied surface coating to purpose made secondary linings.*
- NOTE 3** *Road surface reflectance can vary according to the materials used and the state of wear. Typical average reflective values are 0.05 for porous asphalt, 0.07 for standard asphalt and 0.3 for plain concrete. The dependence of reflectivity on the composition of the road surface is discussed in The CIE/PIARC joint technical report 'Road Surfaces and Lighting' CIE 66:1984 [Ref 11.I] and the method of calculation of the effect on luminance in CIE 140:2002 [Ref 17.I].*

### Tunnel lighting control and monitoring system

- 6.24 The tunnel lighting shall be controlled by an automatic tunnel lighting control system.
- 6.25 The automatic tunnel lighting control system shall regulate all levels of the lighting in daytime to match the minimum lighting level requirements of BS 5489-2 [Ref 10.N] avoiding unnecessarily high lighting levels, ignoring short term variations in external lighting conditions during the daytime caused by passing clouds.

- 6.26 The automatic tunnel lighting control system shall monitor the current and historical status of every lamp or LED assembly.
- NOTE Some control systems offer the possibility of switching out a failed luminaire and adjusting the control of other luminaires to compensate.*
- 6.27 The tunnel lighting control system shall be either:
- 1) a proprietary package with integrated communication with the plant monitoring and control system;
  - 2) an integral part of the plant monitoring and control system.
- 6.27.1 Tunnel lighting control system design should incorporate an automatic standby lighting testing system to minimise the maintenance requirements and number of road / lane closures required to carry out the testing regimes outlined in BS EN 50172, BS 5266-8 [Ref 21.N].
- 6.27.2 The tunnel lighting control system should assess the required light level against the actual light level at a maximum of 3 minute intervals, minimum 15 seconds, and the required adjustment of light level transmitted from the control system to the roadside within 7.5 seconds."
- 6.28 Access zone luminance photometers shall be used to provide the necessary input data for correct daytime operation, in accordance with BS 5489-2 [Ref 10.N].
- 6.29 Three access zone luminance photometers shall be used for each portal, all operating in duty mode, arranged so that if one photometer reads significantly different to the others, or fails completely, an alarm can be raised and the other photometers can continue in normal operation so that there is a majority of readings that can be assumed to be providing a reliable measurement.
- 6.30 Periodic calibration or self-calibration of the units, as recommended, shall be provided.
- 6.31 The tunnel lighting control system shall incorporate an alarm to be raised through the control system, in case of photometer failure.
- 6.32 Where the tunnel lighting control system also controls the standby lighting, the tunnel lighting control system shall be designed to Part 8 of BS 5266 [All Parts] [Ref 23.N].
- 6.33 Where a safety integrity level (SIL) has been defined for the standby lighting, the tunnel lighting control system design shall be to BS EN 61508-2 [Ref 35.N].
- 6.33.1 Tunnel lighting control system should be capable of outputting an indication of when the number of luminaire failures do not permit the tunnel minimum operating requirements to be met.

### **Whole life costs**

- 6.34 The lighting solution shall be selected with the lowest whole life cost and environmental impact without compromising the safety of tunnel users or maintenance personnel.
- 6.34.1 Estimates of the following costs should be factored into the whole life costs:
- 1) initial capital expenditure costs;
  - 2) cleaning and maintenance costs;
  - 3) energy costs;
  - 4) replacement costs;
  - 5) testing and obsolescence.
- 6.34.2 Estimates for initial capital expenditure should incorporate not only the cost of the luminaires but also the associated costs of supporting steelwork, lighting controls, cabling and LV distribution.
- 6.34.3 The cost of replacing either the entire lighting system, or any component of the system, should be included in the cost estimate if the manufacturer's design life of that element is less than 25 years.
- 6.35 Tunnels shall be washed periodically to maintain the wall reflectivity to the level adopted in the design.

- NOTE 1 The continued reflectivity of the tunnel surfaces depends on their state of cleanliness.*
- NOTE 2 The period between cleaning operations can vary according to tunnel usage, season, and geographical location of the tunnel and the actual design of the tunnel.*
- 6.35.1 The cost of maintaining and cleaning the tunnel walls and luminaires should be set against the additional cost of lighting the tunnel to the required standard without cleaning.
- 6.35.2 The design maintenance factor should be 0.7, unless a detailed knowledge of lamp and luminaire depreciation factors in relation to planned maintenance procedures is available and a more accurate maintenance factor can be calculated.
- NOTE 1 The long term permanent deterioration of luminaires and wall finishes can also be taken into account.*
- NOTE 2 For luminaires and control gear enclosures intended to be maintained in-situ, the means of access to the interior for replacement of lamps and/or control gear can have an impact on maintenance costs. End-opening luminaires are easier to seal against the ingress of moisture but normally require complex and expensive mounting brackets and access is generally more complicated. Front-opening luminaires, offering improved access with simpler mounting arrangements, are preferred but care needs to be taken to ensure that the considerably longer gaskets provide a reliable seal at all times to maintain the design IP rating throughout the life of the luminaire. Tool-less access to lamps and control gear will provide for extra efficiency during maintenance operations.*
- 6.35.3 Cleaning and maintenance costs should incorporate the cost of replacement of system components where the manufacturer's mean time between failures (MTBF) figures dictate, this is required.
- 6.35.4 When calculating annual energy costs the following should be stated:
- 1) estimated running hours for each stage/dimming level;
  - 2) assumed electricity charge rate for year of opening;
  - 3) assumed electricity price inflation, from Business, Energy and Industrial Strategy (BEIS);
  - 4) discount rate.

## 7. Drainage system design

### General

- 7.1 The drainage system shall be designed to overseeing organisation's drainage requirements and the tunnel-specific factors described in this Section.
- 7.2 Where there is low point within the tunnel, drainage sumps shall be provided to collect any water from inside the tunnel.
- NOTE 1 Unless the vertical alignment of the road through a tunnel is a crest curve, it is normally necessary for a road tunnel to be provided with drainage sumps and pumping equipment to collect water from the road surface and discharge it safely.*
- NOTE 2 Where approach roads run downhill towards one or both tunnel portals it is normal to intercept storm water flowing down the approach roads to prevent it from entering the tunnel. For such cases the catchment areas can be extensive and consequently interception facilities can often be large.*
- 7.3 Where there is a sump at the portals it shall be sized to receive water from predicted ground water seepage, tunnel washing and fire fighting, as well as possible spillages from vehicles.
- 7.4 In areas subject to snowfall, allowance shall be made when sizing a sump for melt water from snow and ice brought into a relatively warm tunnel by vehicles. .
- 7.5 Automatic controls shall be provided to regulate the number of discharge pumps operating according to the water level in the sump.
- 7.5.1 The rate of pumping water out of a sump may not need to be the same as the rate of inflow provided that the sump has the required storage capacity, and the sump design needs to be coordinated with that of the pumping equipment to achieve an optimum solution.
- 7.6 Tunnel sumps must be designed to comply with the Dangerous substances and explosive atmospheres regulations UKSI 2002/2776 [Ref 73.N].
- 7.7 Tunnel sumps shall be equipped with ventilation and sensors to detect a build-up of common hydrocarbons and initiate automatic protective measures to prevent an explosive atmosphere developing.
- 7.7.1 Spillages of petrol and oil, in quantity, give rise to an explosive atmosphere, creating a major safety risk in the sump. Measures should include flooding the sump with foam or inert gas to prevent ignition, shutting down pumps and sump ventilation fans to confine the hazard until it can be dealt with, and also to prevent any electrical equipment in the vicinity from igniting the explosive atmosphere.
- 7.8 The complete drainage system shall prevent the propagation of fire or hazardous liquids along, and between, the tunnel bores.
- NOTE The design of a drainage system to channel inflows of water and spillages into one or more sumps, can depend on the length, depth, structure and form of tunnels.*

### Drainage systems

- 7.9 A tunnel drainage system shall be an integral part of a local road drainage system, or be designed as a self-contained facility to collect both ground water and surface water which drain from the tunnel roadways via road gullies or other drainage collection systems and longitudinal drains.
- NOTE Tunnel drainage normally discharges into one or more main sumps and includes facilities to contain road tanker spillages and tunnel wash down water, which is likely to be heavily polluted, prior to safe disposal.*
- 7.10 The tunnel drainage system shall prevent ponding of water against tunnel walls or kerbs.
- 7.10.1 Provision should be made for cross falls in conjunction with gullies at regular intervals or other drainage collection systems to remove surface water and avoid ponding longitudinally and against tunnel walls.

- 7.10.2 All manhole and inspection chamber covers, should be located away from the carriageway so that maintenance and repair operations can be carried out without the need for a lane or bore closure.
- NOTE* *Manhole covers include those for access to sumps, pump chambers, valve pits etc.*
- 7.10.3 Where it is not possible to locate all manhole and inspection chamber covers away from the carriageway, they should be positioned away from wheel tracks, since there is great potential for disruption to tunnel operation in the event of access covers failing or coming loose, presenting a hazard to traffic which needs to be dealt with immediately.
- 7.10.4 Secured or lockable covers should be provided for manhole and inspection chamber covers if required by the outcome of a risk assessment.
- 7.11 Gullies shall be installed at not greater than 20-m intervals to limit the potential flow width of combustible liquids.
- NOTE 1* *The minimum gradient for cross-falls is given in Section 4.*
- NOTE 2* *Guidance and advice for the design of gully spacing can be found in CD 526 [Ref 68.N].*
- 7.12 Access arrangements to all sumps and impounding sumps shall be agreed with the Fire and Rescue Service (FRS).
- NOTE* *Pump stations and sumps are normally sited at the lowest point of a sag curve in the tunnel, and near the portals.*
- 7.13 Control rooms or other buildings shall be located away from open sumps and closed impounding sumps, to avoid the risk of fire or explosion.
- 7.14 Where it is not possible to locate control rooms and other buildings away from open sumps and closed impounding sumps, safety precautions based on an assessment of the risks shall be incorporated into the design of such buildings.
- 7.14.1 Pump stations, sumps and separators/interceptors should be sited where they have a minimum effect on the operation of the tunnel, particularly where regular access for their maintenance is required.
- 7.14.2 Depending on design constraints, drainage sumps should be located outside the tunnel rather than under it and in the carriageway.
- 7.15 Pumps shall be sized for the volume of water to be discharged.
- 7.15.1 The working volume for the sump should be between high and low level limits with allowance for surge and residual water cover where submersible pumps are used.
- NOTE 1* *The sizing of sumps and separators is largely an iterative process in conjunction with the pump capacity and maximum inflow rate. Constraints on available power, size of pumping main, allowable discharge rate and the size of sump that can be accommodated all contribute to deciding the final sump volume and pump capacity.*
- NOTE 2* *Large pumps which only operate for short periods increase the cost of energy supply disproportionately because of their increased starting and running current demands.*
- 7.15.2 As a general rule, the number of pump starts per hour should not exceed 12.
- 7.15.3 The number of pump starts per hour should be taken into account when determining the size of pumps/sumps and control level.
- 7.16 Tunnel structure drainage inspection chambers shall be provided at a maximum spacing of 50 m for ease of inspection and rodding.
- 7.16.1 Tunnel structure drainage pipes should be sized to make allowance for blockages.
- 7.16.2 Provisions should be made to allow for tunnel structure drains to be flushed regularly.
- NOTE* *Tunnel structure drains often become blocked by substances such as calcium compounds leaching out of concrete, groundwater salts, silt and construction site debris.*

**Effluent standards: consultation with authorities**

7.17 Constraints on quality and quantity of tunnel discharge monitoring regimes and testing drained liquids, shall be agreed with the local water authority, environmental and public health authorities together with any requirements for a trade effluent agreement.

*NOTE 1 Highway authorities usually have a statutory right, subject to the requirements of the local water authority for discharge to sewers or the relevant environmental protection agency, for discharges to watercourses or similar stretches of open water.*

*NOTE 2 Water from tunnel wall washing, fire fighting and washing down following a spillage is likely to be significantly polluted and potentially harmful to the environment. Only unpolluted drainage water is normally discharged into a surface water sewer or watercourse.*

7.18 Petroleum products must not be discharged into a public sewer as it is an offence under 'Section 111 Restrictions on use of public sewers, Water Industry Act 1991' UKPGA 1991/56 [Ref 85.N].

*NOTE All water authorities insist on the separation, and separate disposal under special arrangements, of any petrol, oil or grease that can be spilt in a tunnel, before the drainage water is discharged.*

7.18.1 Discharge should cease if the salinity of the drainage water exceeds a certain figure or, if the acidity or alkalinity are outside a certain range. The precise restrictions can depend on the place of disposal agreed.

**Inflows into the tunnel**

7.19 The tunnel drainage system shall be designed for the following inflows:

- 1) ingress of ground water and the drainage of the tunnel structure;
- 2) precipitation and runoff;
- 3) tunnel wall washing;
- 4) water from the use of fire hydrants and fixed fire fighting systems;
- 5) wash down following spillages of dangerous goods within the tunnel.

**Precipitation and runoff**

7.20 Precipitation and runoff shall be calculated in accordance with CD 522 [Ref 18.N].

**Wall washing**

7.21 The quantity of water from wall washing shall be calculated, or a rate of 5 l/m<sup>2</sup> of wall area over the period of cleaning used if there is no information available to make a better assessment.

**Fire fighting water**

7.22 The drainage system shall be sized to accept the maximum flow of water from any fixed fire-fighting system in addition to the maximum flow of fire water that can be delivered by the fire hydrant system (see Section 8).

7.23 Where a fire main can be vulnerable to damage from a traffic incident, the duty of the drainage pumping system shall include for the potential outflow from a broken pipe based on its pressure/flow calculations.

**Wash-down water**

7.24 The quantity of wash down water shall be based on the proposed method to be used which may rely on use of the fire main or stand-alone equipment and tankers brought in to the tunnel.

**Sumps, separators and pumping stations**

7.25 Each drainage sump, or interconnected series of sumps, shall be of sufficient capacity to contain the volume of drainage water.

- 7.26 Each drainage sump, or interconnected series of sumps shall have the capacity of at least 50m<sup>3</sup> (capacity of the sump or sumtotal ps) to retain any spillage of flammable or other hazardous liquids, up to the maximum capacity of one full road tanker.
- 7.26.1 Water storage capacity should be provided to contain any inflow in excess of the maximum pumping rate.
- NOTE* Where large sumps can be justified, they offer the opportunity to minimise the size of pumps.
- 7.27 Sump structural depths shall be calculated to allow space above the highest water level for formation of a fire suppressant foam blanket and to accommodate a floating skimmer pump or suction head, if provided.
- 7.28 The overall structural depth shall be sufficient for pumps to work effectively without risk of cavitation and for correct operation of level detection equipment.
- 7.28.1 The general arrangement of the sump should be designed for the following:
- 1) for ease of cleaning and to minimise the risk of grit deposition;
  - 2) to minimise any requirement for manned access to the sump for maintenance purposes; and
  - 3) to minimise any turbulence around the pumping plant, arising from high inflow rates, and which can impair the performance of the pumps.
- 7.29 A forced ventilation system shall be provided for any closed sumps within the tunnel to provide a safe atmosphere for personnel working in the void.
- NOTE* A forced ventilation system can dilute any potentially dangerous atmosphere, including that due to accidental spillage on the carriageway, and remove any fire extinguishing gases.
- 7.29.1 Where possible, sumps outside the tunnel should be naturally ventilated.
- 7.30 A combustible gas detection system shall be provided to detect any flammable vapour in the sump.
- 7.31 The combustible gas detection system sensing shall be arranged in two stages corresponding to low and high concentrations of hydrocarbon gases.
- 7.31.1 The design of sumps should include measures to prevent structural damage due to explosion and its transmission where there is an adjacent interconnecting sump.
- 7.32 Separators shall be specified in accordance with BS EN 858-1 [Ref 65.N].
- 7.33 Separators shall be designed for ease of cleaning and be ventilated to prevent the accumulation of dangerous gases.
- 7.34 Separators shall be designed to minimise the risk of oil or other hydrocarbon substances, trapped in the separator, from being flushed through under high flow conditions.
- 7.34.1 Interceptors/separators should be of sufficient size to allow separation of the pollutants, particularly where their operation depends upon reduced velocity across the unit.
- 7.35 Sumps shall be classified as hazardous areas in accordance with BS EN 60079-10-1 [Ref 28.N].
- 7.36 All pumps and electrical equipment located in sumps areas shall have the standard of protection appropriate to the zone, in accordance with BS EN 60079-10-1 [Ref 28.N].
- 7.37 The areas around access hatches, covers and ventilation outlets shall be in accordance APEA publication APEA Blue Book [Ref 2.I].
- NOTE* The APEA publication APEA Blue Book [Ref 2.I] includes design criteria, as follows:
- 1) around access hatches, zone 2 extending horizontally for a radius of 3 m from the edges of the manhole in all directions at 1.25 m height, increasing to 4.25 m radius at ground level; and
  - 2) around ventilation pipe outlets, zone 1 over a radius of 3 m in all directions from the open end of the vent pipe and zone 2 vertically below the zone 1 area and down to ground level.

### Impounding sump

- 7.38 Wherever one or more sumps are provided within the confines of a tunnel, one or more closed impounding sumps shall be provided in a safe location to receive and impound safely any hazardous liquids that flow into the tunnel sump.
- 7.39 All impounding sumps shall be provided with a safe means of inspecting and sampling the contents, and provision for disposing of the contents either by means of an equipped road tanker or, if agreed with the relevant authority, by pumping into the public foul sewerage system.
- 7.39.1 Where evacuation of the impounding sump by road tanker is proposed, a suitable off-road parking area should be provided adjacent to the discharge point for use by tanker lorries.
- 7.40 The drainage system shall be designed to continue to operate even while a hazardous liquid is being held, pending disposal.
- 7.41 Removal of oil and similar lighter-than water hydrocarbons shall also be catered to.
- 7.42 The method of detection, containment and disposal of hazardous spillages shall be agreed with the Fire and Rescue Service (FRS), the water authority and the relevant environmental protection agency.
- 7.42.1 The Fire and Rescue Service may require a pipework connection for FRS hoses via a fire main connection box to allow FRS to pump foam into the sump if necessary.
- 7.43 The design and selection of impounding sumps shall be based on one of the following two approaches:
- 1) All liquids flowing into the tunnel sump under normal operations are assumed to be contaminated to some degree, but not hazardous, and suitable for pumping out into a sewer or watercourse. In the event of maintenance cleaning or a potentially hazardous or environmentally harmful spillage, a diverter valve could be operated to direct the spillage and any subsequent wash-down water into the impounding sump. This method requires rapid action to be taken in the event of an actual or suspected spillage to capture the liquid before it is discharged;
  - 2) All liquids flowing into the tunnel sump under normal operation are assumed to be potentially hazardous and are pumped directly into the impounding sump. During tunnel washing, hydrant testing or similar maintenance operations producing large quantities of water that can be discharged into a foul sewer, a bypass valve could be operated to enable this to be done. This method means that no action needs to be taken to capture a spillage, but has the disadvantage that any normal flows, including seepage of groundwater into the tunnel, can also be pumped into the impounding sump and require removal and disposal.
- 7.44 Impounding sumps shall continuously report the level of liquid in the sump, the available working volume to accept a spillage, and the presence of a flammable or oxygen depleted atmosphere to the monitoring station.
- 7.45 Ventilation and fire protection equipment shall be provided for impounding sumps as for all other closed sumps.

### Pumping plant

- 7.46 The pumping plant shall be designed for:
- 1) the maximum expected inflow to the sump;
  - 2) the average normal expected inflow to the sump, design constraints imposed by the tunnel's structural form;
  - 3) maximum discharge limitations;
  - 4) discharge system parameters; and
  - 5) the size of the sump.
- 7.46.1 System/duty curves should include for several options of pipe size, in order that minimum carrying velocity and acceptable power requirements can be achieved.

**NOTE** *The maximum rate at which water can be pumped out can be determined by the local water authority's consent to discharge, but this can be considerably greater than the expected rate under average conditions. Two or three pumps are often adopted, which with all in operation is adequate to pump at the maximum rate, but individually is sufficient to handle the average rate. Pumping rates can also be varied by the use of variable speed drives.*

- 7.47 The duty of standby pumps shall not be included in the pump capacity calculations.
- 7.48 Pump operation shall be rostered to ensure that pumps share duty and standby operations evenly.
- 7.49 Where pumps have to deal with hydrocarbon liquid spillage they shall be capable of pumping it without risk of damage to the pump seals or ignition of the hazardous liquid.
- 7.50 Electrical connectors, rated for use in wet and hazardous atmospheres, shall be provided so that entry into the sump is not required for the connection or disconnection of the pump.
- 7.51 Submersible type pumps shall be removed in total when inspection, repair or overhaul is required.
- 7.52 Full functionality of the pumping system shall be maintained whilst one pump is removed or has failed.
- 7.53 All plant and metallic pipework shall be electrically bonded to ensure that metalwork is maintained at the same potential.
- 7.53.1 Bonding should be designed so that items such as valves and pumps that can need to be removed for maintenance or inspection can be removed without disrupting the continuity of the bonding system.
- 7.54 Motor control gear, cables and transformers shall be located in a separate non-hazardous area away from the sump and above any relevant flood level.
- 7.55 Where level controls are required they shall provide the relevant resolution and accuracy of measurements required and allow for the effects of turbulence and ripples on the water surface.

**NOTE** *Float switches can be the cheaper option and with proven reliability, but are unsuitable for very shallow sumps such as those provided in immersed tube tunnel sections. Level detectors for a wide, shallow sump need to detect much smaller changes in level than those in a narrow, deep sump, and will be much more susceptible to false readings caused by surface effects. Ultrasonics and radio frequency devices have the advantage of not requiring contact with the water.*

- 7.55.1 Sludge pumps may be necessary to remove deposits of solid matter in the invert of the sump and thus avoid the need for periodic cleaning by manual labour, in a confined space.
- 7.55.2 A reflux (or non-return valve) and an isolating valve should be provided adjacent to each pump.
- 7.55.3 The isolating valve for the sump should be located downstream of the reflux valve to enable maintenance to be carried out on the latter, as well as the pump.
- 7.55.4 Isolating valves for the sump should be situated in an accessible place such that they can be maintained without requiring manned access to the sump.
- 7.55.5 Pipework for connection to a bowser vehicle to permit spillages in the sump to be emptied independently of the main pumps or discharge pipework should be provided.

### **Discharge pipework**

- 7.56 Pressurised pipework, shall be designed to cater for thrust forces at changes in direction and gradients.
- 7.56.1 Pipework should be designed to avoid sharp changes in direction, to minimise friction losses and prevent erosion where abrasive suspensions can be expected to be carried.
- 7.57 Pipe fittings shall include air release valves and drain down points.
- 7.58 Materials shall be selected to avoid the risk of toxic fumes being generated in the event of a fire.

**NOTE** *The choice of pipe materials and protective treatments can depend upon whether the pipework is buried, cast in, or in an open situation. Other factors can be the expected contaminants in the water, costs and ease of installation and maintenance.*

## Safety

- 7.59 The normal operation of the sump extractor fans shall be on an automatic timed basis for 15 minutes per hour (based on a minimum of four air changes per hour when running continuously).
- 7.60 Ducting shall be provided for the supply and exhaust air to the sump.
- 7.61 Flame traps shall be incorporated to the sumps ducting, where necessary.
- 7.61.1 Bifurcated duty and stand-by extraction fans should be provided in sump areas.
- 7.62 In order not to prematurely expel gases used for fire protection in the sump, the automatic fan system shall be interconnected with the fire prevention system's heat detectors so that the fan(s) are switched off upon detection of a rise in temperature, within the sump.
- 7.63 The gas detectors located in the sump shall switch off the fans in the event that a combustible gas, or oxygen deficiency, is detected.
- 7.64 To expel gas, a manual override for use by the FRS or maintenance personnel shall be provided to allow the fans to be operated continuously from the pump control panel.
- 7.64.1 Where gas is vented into the tunnel, this should only occur in conjunction with the operation of the main tunnel ventilation system.
- 7.64.2 Sumps should be emptied before venting, as forced ventilation of a sump containing volatile fuel can generate excessive quantities of combustible vapour.
- 7.65 Where electrical equipment is not fully protected, a minimum design criterion of 1 part of sump gas to 50 parts of tunnel air shall be adopted.
- 7.66 Provision for detection of gas at low and high concentrations shall include for an alarm to be raised at the monitoring station, and also be displayed on the pump control panel.
- 7.66.1 The alarm (high) condition should initiate automatic operation of a fire extinguishing system, if fitted, to render the sump inert.
- 7.67 The sampling from one of the gas detection system detectors shall take place just above water level in the sump.
- NOTE Gas sampling just above water level in the sump can be achieved by attaching the sampling tube to a raft or float that can rise or fall with the water level.*
- 7.68 The fire extinguishing system shall be initiated automatically upon detection by heat detectors, of a rise in temperature due to a fire in the sump.
- 7.69 It shall be possible to manually operate the fire extinguishing system from a local fire control panel.
- 7.70 Spillage of hazardous or other substances which do not give off combustible gases, but which could be undesirable to pump into local water systems shall be identified by the monitoring and surveillance systems.
- NOTE Detection of substances that reduce the amount of oxygen in the atmosphere, can be achieved by oxygen deficiency detectors arranged to set alarms when oxygen falls below a preset value.*
- 7.71 On detection of a hazardous substance entering a sump, the detection system shall switch off the plant to allow manual operation and control.
- 7.72 All detector sensors within the sump shall be duplicated.
- 7.73 Internal detectors such as pellistors shall be capable of being easily replaced, without requiring manned access to the sump.
- NOTE Internal detectors need to be easy to replace as they generally have a short life.*
- 7.74 Sensors within the sump shall be protected from degradation..

**Fire precautions**

- 7.75 Sump ventilation air supply and exhaust ducts, where connected into the tunnel atmosphere, shall be provided with flame traps.
- 7.76 To limit flame passage through the drains, in the event of a fuel spillage and fire, U-bends shall be incorporated, where there is access for cleaning the drain, at the inlets to the sump and at the carriageway gully pots or traps.
- 7.76.1 Where there is no access for cleaning the drain, equivalent fire-proof drainage systems may be used to limit flame passage through the drains.
- NOTE For the fire protection requirements of all drainage sumps, refer to Section 8.*

## 8. Fire engineering

### General

- 8.1 This section provides technical criteria that shall be applied for road tunnel fire safety assessments as well as for plant and safety facilities.
- 8.2 The technical criteria shall be provided as both passive and active fire protection for tunnel users and this section includes requirements for the evaluation of design fire magnitudes.
- 8.3 Design fire magnitudes shall be used in the design of a tunnel ventilation system and for the design of a tunnel structure passive fire protection system.

**NOTE** *Fires in tunnels are particularly hazardous to life because of the following:*

- 1) *potential concentration of fumes and poisonous gases;*
- 2) *temperatures and heat radiation that can reach 1200°C and above;*
- 3) *reduced visibility;*
- 4) *the possibility of panic among tunnel users;*
- 5) *the difficulties which can be experienced by fire fighters working in an enclosed space.*

### Management of fire risk

- 8.4 The level of tunnel fire and life safety provision to be included to achieve tunnel user safety shall be determined by regularly reviewed risk assessment.
- 8.4.1 It may be necessary to evaluate the level of risk of loss of use of the tunnel, due to damage from a serious fire, in terms of the societal and economic impact on the surrounding area.
- 8.5 The design shall include provision of facilities for communications, traffic surveillance and control, tunnel ventilation where deemed necessary and drainage systems, tunnel layout for safety, emergency lighting and pre-planned and tested firefighting procedures to allow effective firefighting in response to emergencies.

### Safe evacuation & structural damage limitation

- 8.6 In tunnel fire incident conditions an installed tunnel ventilation system, where provided, shall create an environment within the tunnel and all dedicated escape routes that allows:
- 1) tunnel users to evacuate the incident bore safely; and
  - 2) fire and rescue services personnel safe access to the incident site.
- 8.7 A structural fire protection system, shall be provided to reduce damage caused to the tunnel structure, in the event of a fire.

**NOTE** *The extent of potential structural damage can be dependent on both the fire load and the fire duration, the latter being determined by the capacity of the drainage and ventilation systems within the tunnel, the quantity of combustible material involved in the fire and the firefighting provisions available.*

- 8.8 A fixed firefighting system (FFFS) such as deluge or water mist systems, where provided, shall be suitable for use in road tunnels and be effective in reducing the potential magnitude and duration of a tunnel fire.

**NOTE** *Reducing the potential magnitude and duration of a tunnel fire can assist in tunnel user evacuation and emergency service access as well as limiting potential structural damage and reinstatement time.*

- 8.9 In tunnel fire incident conditions mechanical ventilation, passive structural fire protection and fixed firefighting systems, where they are included, shall collectively achieve:
- 1) safe tunnel user evacuation conditions;
  - 2) safe conditions for emergency service personnel to access the incident site;

- 3) prevent/delay onset of structural damage/failure;
- 4) minimise potential structural damage, consequently minimising the duration and cost associated with reinstatement works including M&E assets and cabling and tunnel closure.

### Environmental issues

8.10 The design shall include an environmental impact assessment of possible emergency incidents, including fires and toxic spills, within the tunnel.

8.10.1 An environmental impact assessment should include:

- 1) effective dispersion of tunnel fire incident smoke and products of combustion as well as potentially harmful vapours or gases released in tunnel spillage incidents;
- 2) containment and/or disposal of water, foam or chemicals used for firefighting, including active fire suppression systems where installed.

### Tunnel passive fire protection

8.11 Passive fire protection shall be provided where deemed necessary by risk assessment.

8.12 Where installed, passive fire protection shall be capable of, during the evacuation phase:

- 1) safeguarding the structural integrity of the tunnel by protecting the concrete, reinforcement steel, pre-stressed steel etc. from extreme temperatures that can cause failure;
- 2) improving spalling resistance to protect tunnel users and firefighters from falling spalling material or equipment;
- 3) protecting power and communications cabling;
- 4) protecting mechanical components within the tunnel, particularly the effects of high temperatures on the integrity of fixings and supports for heavy or suspended items of equipment such as jet fans; and
- 5) limiting structural damage caused by the fire and minimising time and cost of any reinstatement works.

### Tunnel structure

8.13 An analysis of the effects a design magnitude fire, as determined by risk assessment, can have on the tunnel structure, including associated ducts and shafts, shall be undertaken and all structurally critical elements identified.

8.14 Fire/heat protection shall be included in the design for all structurally critical elements.

8.14.1 Additional fire protection layers to structures, may not be required if analysis determines that fire incident damage cannot cause failure of the structure.

8.15 All exposed structural steel-work in the tunnel shall be provided with fire protection in accordance with BS EN 1993-1-2 [Ref 26.N] to reduce the risk of collapse.

### Cables & equipment

8.16 Passive fire protection measures shall be implemented so that all systems, cabling and equipment carrying out life-safety functions are capable of carrying out their designated function under the design fire conditions, during the evacuation phase.

*NOTE The requirements for performance of cables in fire conditions is addressed in Section 11.*

8.16.1 Passive fire protection may be a barrier of thermally insulating material designed to limit the temperature rise to which equipment or cables can be subjected, or inherent fire resistance of the equipment or cables themselves.

- 8.17 All longitudinal power, control and communications cables shall be enclosed in cable ducts beneath the verge or in service tunnels/sub-tunnels.
- 8.18 Cable ducts shall either be a trough type with close fitting covers or, be totally enclosed circular ducts either cast within the structure or fully enclosed within containment, constructed from fire protective material.
- 8.19 The ducts shall be designed to:
- 1) Protect the enclosed cables from heat degradation when subjected to a constant surface temperature of 400°C for a minimum period of two hours with access covers in place;
  - 2) Prevent the unrestricted spread of fire or combustion products where ducts enter chambers or draw pits.
- 8.20 Equipment terminating chambers and cable entry into equipment mounted into verge ducts shall have a minimum two hours resistance to design fire conditions.
- 8.21 Design shall include provision for prevention of combustible gases permeating un-ventilated ducts, cable chambers etc.

### **Secondary cladding**

- 8.22 Tunnel structures provided with a separate secondary cladding finish secured to a support framework off of the main structure, shall include fire stops within the void at 30 m intervals.
- 8.23 Cladding shall be non-combustible and made from material that prevents toxic gases, or smoke being generated in the event of a tunnel fire.

### **Design fire loading for structural fire protection**

#### **Vehicle fire**

- 8.24 The potential tunnel fire magnitude for which structural fire protection is provided shall be determined by risk assessment based upon:
- 1) tunnel traffic volumes;
  - 2) traffic composition;
  - 3) vehicle fuel types (petrol/diesel/liquid petroleum gas/other fuel technologies);
  - 4) potential cargo loads;
  - 5) road type;
  - 6) tunnel location;
  - 7) all additional fire safety facilities to be included;
  - 8) the potential for multiple vehicle or hazardous vehicle incidents to occur; and
  - 9) tunnel type.
- 8.24.1 The fire loads from vehicles/combustible contents, and the associated fire growth conditions from which the structure should be protected are given in Table 8.24.1.

**Table 8.24.1 Fire loads & growth rates**

Peak Heat Release Rate (HRR) in MW		Example road vehicles	Fire growth curve (at surface of structure)	
Risk to life		5	1-2 cars	ISO 834
		10	Small van, 2-3 cars	ISO 834
		20	Big van, public bus, multiple vehicles	ISO 834
		30	Bus, empty HGV	ISO 834
	Risk to structure	50	Truck with combustible load	ISO 834
		70	HGV with combustible load (approx. 4t)	HC
		100	HGV (average)	HC
		150	HGV with easily combustible load (approx. 10 t)	RWS
		200 or higher	Petrol tanker, multiple HGV, limited by oxygen.	RWS

**NOTE 1** The fire magnitude values given in the table are typical and there can be variation in fire load between different vehicles within each classification.

**NOTE 2** Table 8.24.1 is taken from "Design fires in tunnels" Ingason 2006 [Ref 6.1] which presents the main results from the UPTUN research project and a UPTUN Work Party 2 (WP2) proposal for design fires.

8.24.2 The following linear fire growth rates recommended by UPTUN – WP2 may be applied in defining the design fire loading for structural fire protection, however, these represent extreme case (rapid) fire growth conditions:

- 1) Peak HRR of fire  $\leq 30\text{MW} = 10 \text{ MW/min}$ ;
- 2) Peak HRR of fire  $> 30\text{MW} = 20 \text{ MW/min}$ .

**NOTE 1** UPTUN – WP2 also outline less onerous fire growth rates derived from a review of full-scale fire test data as advice for determining ventilation system design fire.

**NOTE 2** The duration of a fire can be determined by the amount of available combustible material ( $E_{tot}$ ), where 100% fuel consumption (80% combustion efficiency) is assumed.

**NOTE 3** The amount of fuel evaluated for each study can depend on the type of vehicles, vehicle loads and traffic patterns with stationary traffic having a large influence on the amount and availability of combustible material.

**NOTE 4** Incidents involving hazardous goods vehicles can result in the spillage of hydrocarbon fuel, either in its gaseous or its liquid form and leakage of liquid hydrocarbons, typically petrol, can result in pool fires upon ignition.

**NOTE 5** The consequences of a release of liquefied petroleum gas (LPG), due to its high volatility, is different to those of a petrol spill. The combustion events associated with gaseous releases from LPG vehicles

*are, in general, more intense and potentially including jet fire, fireball and vapour cloud explosion effects in addition to pool fires.*

8.25 Calculation of design fire duration shall take into account the effect of drainage in reducing the potential duration of a liquid fuel spill fire.

*NOTE 1 The exact leakage rate from a damaged tanker is not predictable and the spill rate required to produce a maximum fire intensity in excess of 100 MW can be higher when drainage is effective.*

*NOTE 2 The effect of drainage can be to reduce the duration of a fire but not to reduce the maximum intensity.*

8.26 When the design fire magnitude and duration have been established, the fire temperature profile along the tunnel, and subsequent heat transfer to the tunnel structure (and concrete and reinforcement steel temperatures) shall be determined.

8.27 The design fire magnitude/duration along with fire temperature linear profile and subsequent heat transfer to the tunnel structure shall be used to determine the extent of passive structural fire protection to be provided.

8.27.1 Where risk assessment determines that protection against tunnel fires involving HGV's is to be included, a minimum design fire load of 100MW should be used.

*NOTE The final choice of fire load for which structural fire protection is to be provided, depends on a cost-benefit analysis of increased fire protection balanced against potential structural reinstatement, social and economic costs, impact on air quality etc., following a tunnel fire incident.*

## **Passive fire protection system**

### **Design requirements**

8.28 Passive fire protection shall be designed to protect a concrete tunnel structure by limiting the temperature of the concrete surface interfacing with the passive fire protection and limiting the temperature of the reinforcement nearest to the interface surface under the design fire conditions.

8.29 Where the tunnel structure has movement joints, the fire protection system shall be detailed to accommodate articulation and movement to prevent the risk of cracks occurring in the fire protection.

8.30 Joint detail within the fire protection system shall be such that it prevents flames going through the gap and affecting the structure.

8.31 The passive fire protection system design shall include inspection panels allowing inspection and maintenance access to bearings, drainage channels or any other tunnel elements as required.

8.32 Where recesses and cut-outs are formed in tunnel walls, and the fire protection stops around them, the edge detail of the fire protection shall be such that it is not vulnerable to mechanical damage.

8.33 Fire protection in areas of impact with moving vehicles shall be provided mechanical protection.

8.34 Where seepage of water through a tunnel structure that cannot be effectively sealed is a possibility, positive drainage provision shall be made so that the performance of the fire protection system is not affected for the duration of its design life.

*NOTE Without a positive drainage system the passive fire protection material can potentially absorb water, undergo change in properties and increase its self-weight, resulting in the overloading and possible failure of the fixings.*

8.35 The design of sprayed and board fire protection systems and their fixings shall allow for vehicle induced air pressure fluctuations as well as the effects of high pressure jet washing using detergents to clean the tunnel.

*NOTE The movement of vehicles in a tunnel can create rapidly changing positive and negative pressure loads.*

8.36 The fire protection system shall be suitable to be painted or receive an appropriate coating, to achieve the reflectance level to meet the requirements for the lighting design.

- 8.36.1 Board fire protection systems including cut holes and edges, should be appropriately coated, to prevent rapid deterioration by water ingress.

### Active fire protection requirements

- 8.37 Active fire protection systems shall be sub-divided into those that are designed subject to a peak heat release rate, e.g. ventilation and fire suppression, and those that are independent of fire size, e.g. fire hydrants, fire extinguishers etc.

### Design fire magnitude selection for ventilation

- 8.38 A tunnel fire incident risk assessment shall be undertaken based upon predicted tunnel traffic volumes and composition, applying historic traffic incident data for adjacent sections of open road (assuming the same category of road and similar traffic flows to the tunnel), or criteria based on the level of risk at a range of comparable existing tunnels with similar traffic regimes.

*NOTE The design fire scenario appropriate for tunnel ventilation design can be different from that adopted for passive fire protection of the tunnel structure and equipment. The tunnel ventilation system design priority is safe tunnel evacuation, whereas for passive fire protection it is to limit damage to the structure (preventing structural failure) and as such minimising repair time and cost.*

- 8.39 The tunnel fire incident risk assessment shall include the potential for multiple vehicle or hazardous vehicle incidents to occur.

- 8.39.1 Where historical fire frequency data is used it should be adjusted to reflect any underlying differences in safety provision.

- 8.39.2 Fire frequencies used in the tunnel fire incident risk assessment may be estimated from personal injury accident rates, and estimates derived for the ratio of serious fires to injury accidents.

*NOTE The fire frequency (fires/year) is given by the product of traffic flow (vehicle-kilometres per year), accident rate (accidents per vehicle-kilometre) and fire/accident ratio.*

- 8.40 The tunnel fire incident risk assessment shall determine a predicted frequency of tunnel fires for a range of fire incident types ranging from motorcars to fully laden HGV's and fuel tankers.

- 8.41 The tunnel ventilation design fire magnitude shall be based upon the findings of the tunnel fire incident risk assessment and the installed safety facilities at the road tunnel.

- 8.41.1 In tunnel design fire conditions operation of the correspondingly sized tunnel ventilation system at its incident condition setting should create conditions whereby tunnel users can evacuate the tunnel safely, assuming rapid awareness of the incident occurrence and prompt activation of the ventilation response.

- 8.41.2 The design should allow for the time period between fire incident ignition and detection and the subsequent initiation of the planned incident response(s).

- 8.41.3 Effective use of automatic incident detection equipment should minimise the time period between fire incident ignition and detection and the subsequent initiation of the planned incident response(s).

*NOTE 1 A review of data from full-scale fire tests, designed to simulate a range of vehicle fire types, has established that a typical fire is likely to grow relatively slowly to between 1 & 2 MW in the first 4 to 6 minutes from ignition, after which it can grow more rapidly at between 5 & 15 MW/min until it is limited either by availability of fuel or oxygen.*

*NOTE 2 The rate of growth can be affected significantly by the prevailing airflow (either natural or ventilated) through the tunnel at the time.*

### Water-based fixed firefighting systems

- 8.42 A fixed fire fighting system (FFFS) such as a deluge or water mist system shall be included where it has been determined that an installed mechanical ventilation system alone is unable to maintain a tenable environment on emergency escape routes allowing the safe evacuation of tunnel users.

- 8.42.1 Costs should be assessed taking into account closures for FFFS maintenance and any reduced closures due to FFFS use, following a fire.
- 8.42.2 FFFS may be considered as a compensating feature for an existing ventilation system not capable of addressing the expected fire scenarios.
- 8.42.3 The case for installing in high risk areas only, should also be looked at.
- 8.43 Fixed fire fighting systems (FFFS) shall be suitable for use in road tunnels.
- 8.44 FFFS shall be capable of:
- 1) fire suppression - reduction of the heat release rate over the design duration of discharge;
  - 2) fire control - stopping or significantly slowing the growth of a fire within a stated period of time so that the peak heat release rate is significantly lower than it can be without use of the fixed firefighting system;
  - 3) volume cooling - substantial cooling of the products of combustion without directly affecting the heat release rate; and
  - 4) surface cooling - direct cooling of specified structural components, fittings or equipment without directly affecting the heat release rate.
- 8.45 FFFS performance criteria shall address the following:
- 1) the rate of growth and potential peak heat release rate of the design fire;
  - 2) the likely times to detect and confirm a fire and to activate the fixed firefighting system;
  - 3) the shielding effect of vehicle bodies and other obstructions;
  - 4) the range of potential air velocities in the tunnel; and
  - 5) tenability requirements for safe evacuation and firefighting activities.
- 8.46 The length of time for which the FFFS is required to operate shall not be less than one hour from activation.
- 8.47 Operation of a FFFS in parallel with an installed mechanical ventilation system shall be proven not to prevent either system from achieving its design duty.
- 8.48 Acceptance criteria shall be selected to be demonstrable practically either by:
- 1) full scale fire tests on a mock-up of a section of the tunnel and fixed firefighting system; or,
  - 2) use of computational fluid dynamic modelling to simulate the performance of the fixed firefighting system, validated and calibrated against actual test data for a comparable system.
- 8.49 Where chemicals or additives are used in a fixed firefighting system, they shall be in compliance with the requirements of LA 113 [Ref 57.N].

### **Emergency panels in tunnels**

- 8.50 Emergency panels shall be manufactured from a corrosion resistant grade of stainless steel suitable for use in the road tunnel environment, folded and seam welded, to provide a minimum of IP66 ingress protection.

*NOTE* A typical emergency panel layout is given in Figure 8.50N for guidance.

Figure 8.50N Typical emergency panel layout

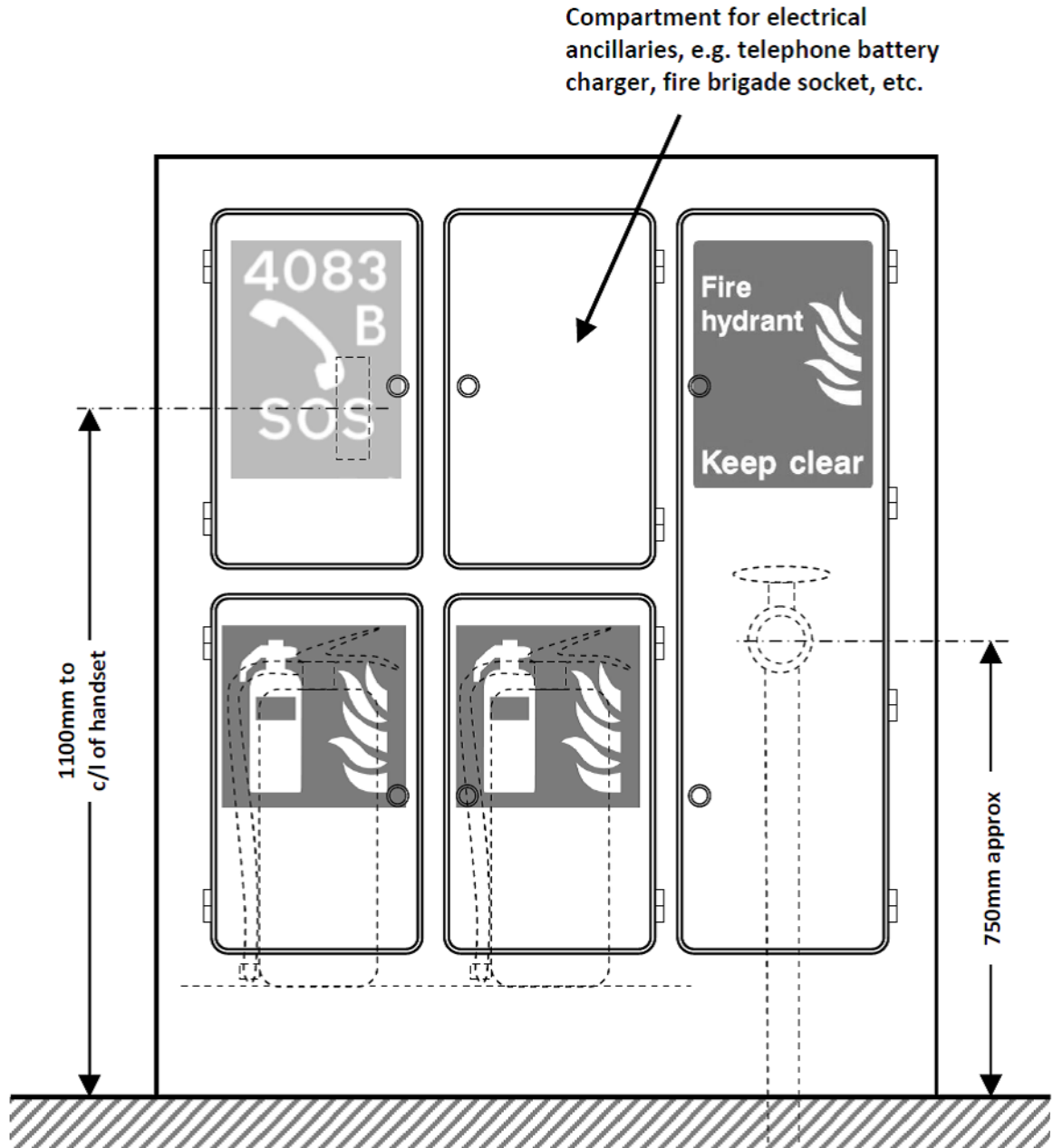

8.51 Panel signing and labelling shall be in accordance with ISO 7010.

8.52 Emergency panels shall be positioned in accordance with Section 3.

8.53 Emergency panels shall include:

- 1) two portable fire extinguishers for class A, B & C fires in dedicated compartments;
- 2) an emergency telephone connected directly to the police or tunnel/ traffic control centre;
- 3) socket outlets, see Section 11;
- 4) permanently illuminated emergency signs; and
- 5) a clearly visible number to assist with identifying location in respect to an incident.

8.53.1 FRS should be consulted on the need for socket outlets.

- 8.54 Road user accessible equipment within the EP shall be located in accordance with published DfT guidance, Inclusive Mobility Inclusive Mobility [Ref 40.N].
- 8.55 Emergency panel socket outlets shall be on UPS where required and agreed by fire and rescue service to power tools.
- 8.55.1 Emergency panels (EPs) may be amalgamated with electrical distribution panels to form emergency/distribution panels (EDPs).
- 8.55.2 An EP can have an EDP, but they should be differentiated as one poses a hazard and the other presents facilities to aid during incidents.
- 8.56 The electrical distribution section of an EDP shall be segregated in accordance with See Section 11.
- 8.57 Emergency panels shall be safely accessible by all road tunnel users, including wheelchair users.
- 8.58 Doors to fire extinguisher compartments shall include monitoring provision, to give an alarm signal to the police or tunnel/traffic control centre when a door is opened or a fire extinguisher is removed.
- 8.59 Life safety systems shall be designed in accordance with the requirements of BS EN 61508-2 [Ref 35.N].

### **Fire extinguishers**

- 8.60 Portable fire extinguisher types shall be in accordance with BS EN 3-10 [Ref 52.N], fire rating 21A, either:
- 1) 3-kg dry-powder, stored pressure type, with a pressure gauge, and coloured red with a blue label; or
  - 2) 9-litre AFFF (aqueous film forming foam) electrically tested, complete with CO<sub>2</sub> charge container and coloured red with an off-white label.

### **Hose reels**

- 8.61 Hose reels shall not be provided unless deemed necessary following consultation with the fire and rescue service and other stakeholders.
- 8.62 Where provided, hoses shall have maximum sectional lengths of 30 m with 19 mm internal diameter..
- NOTE Assuming that emergency panels are located at 50 m centres, sectional lengths of 30 m hose can enable discharges from adjacent hoses to overlap.*

- 8.63 Water flow rate and pressure shall be in accordance with BS EN 671-1 [Ref 34.N].
- 8.63.1 Hose reel water supply may be from the tunnel fire main.
- 8.63.2 Hose reels supplied from the tunnel fire main may need pressure reducing valves.
- 8.64 Fire hose reels shall be protected from freezing in winter.
- 8.65 Hose reels shall normally be of the swinging arm pattern.
- 8.65.1 Where physical limitations in the tunnel prevent the use of a swinging arm pattern hose reel, a fixed pattern, with a fair-lead, may be used.
- 8.66 The hose reel isolating valve shall not be accessible to the public.
- 8.66.1 The hose reel isolating valve should be left in the "on" position at all times.
- 8.67 Drawing the hose off the reel shall automatically start the flow of water into the hose.
- 8.68 The hose nozzle valve shall control the water jet.

### **Public emergency roadside telephones**

- 8.69 Emergency roadside telephone provision shall be in accordance with the requirements outlined in Section 9.

## Communications

8.70 Emergency services communications systems shall be in accordance with the requirements outlined in Section 9.

## Smoke control panels

8.71 The requirement for the provision of smoke control panels at tunnels with installed mechanical ventilation systems, shall be determined in consultation with local fire and rescue services.

8.71.1 The panel should be intuitive and self explanatory, for operation without error by an operator with no training and under time pressures.

8.72 The facilities available for control at the smoke control panel shall be determined through discussion with the emergency services.

8.73 The smoke control panel design and format shall be determined through discussion with the emergency services.

8.74 Where provided, smoke control panels shall in safely accessible locations outside both portals of each tunnel bore.

8.75 The smoke control panel layout shall be suitable for use by fire service personnel who are not familiar with the tunnel or its facilities.

8.75.1 The equipment to be contained in these panels should be discussed and agreed with the local fire authority.

**NOTE** *Smoke control panels can typically include:*

- 1) *basic controls for local override of the tunnel ventilation and tunnel lighting systems;*
- 2) *a facility to assist identifying the location of the fire;*
- 3) *a telephone linked to the tunnel emergency roadside telephone system, with the facility to communicate with the tunnel operator and other smoke control panels on the system;*
- 4) *a microphone and controls for broadcasting messages over the tunnel public address system, where provided; and*
- 5) *tunnel emergency plans and information for use by attending fire fighters.*

8.76 Where smoke control panels are provided, a hierarchy of ventilation system control priority shall be established within the tunnel control system to prevent conflicting ventilation settings being initiated from different SCP's or tunnel control stations.

## Fire main and hydrants

8.77 A minimum of one fire fighting supply main shall be provided for each one way bore of a twin-bore tunnel.

8.78 One fire main shall be provided on each side of a single-bore two way tunnel.

8.79 Fire mains shall be in accordance with local water authority, and fire and rescue service requirements.

8.80 Each end of the fire main system shall be supplied from an independent water source and be fitted with isolating valves and a metering system capable of detecting flow leaks and raising an alarm, when not in operation.

8.80.1 Pumps may be required on fire mains where available water pressure can drop below minimum fire service requirements.

8.81 Where a reliable fire main water supply is not available, one or more break tanks and pumps shall be provided to deliver the required fire hydrant flow rate and pressure.

8.82 Where water meters are installed on supply mains (for routine tunnel water requirements) they shall not prevent fire service flow rates and pressure requirements being achieved at hydrants and hose reels.

- 8.82.1 Where remote monitoring of water usage rates is required, the water metering facilities should be compatible with tunnel monitoring systems.
- 8.83 Hydrants in the tunnel shall be horizontal, bib-nosed or oblique pattern landing valves in accordance with BS 5041-1 [Ref 31.N], branched off of the fire main and located at approximately 750 mm above the verge.
- 8.84 Hydrants shall be provided near the portals and at alternate emergency panels throughout the tunnel at nominal 100-m intervals, and exceptionally no more than 150-m intervals.
- NOTE Guidance on fire hydrant spacing can be found in Section 2.*
- 8.85 Fire hydrant spacing and locations shall be as agreed with the fire and rescue service.
- 8.86 Where fire hydrants are not incorporated into emergency panel cabinets, they shall be placed in individual hydrant cabinets.
- 8.87 Where fire hydrants are required outside, in the tunnel approaches, they shall be to BS EN 14339 [Ref 82.N] and located in the verge.
- 8.88 The required water flow rate, the minimum operating pressure and the maximum design working test pressure of the hose and hydrant system, and the capacity of break tanks (where required) shall be in accordance with the requirements of the local water authority and fire and rescue service.
- 8.89 The fire main shall be capable of delivering a minimum total flow of 1500 litres/minute with up to three hydrants in use simultaneously.
- 8.90 Where a break tank is, or break tanks are, provided, the working capacity shall be at least sufficient for one hour's operation at the determined flow rate.
- 8.91 Hydrants shall be suitable for use with hoses in accordance with BS EN 694 [Ref 32.N].
- 8.92 Fire main pipe sizes shall range between 100 mm to 200 mm diameter, with selection based on available water supply pressures, fire main system pressure losses and fire service required flow rates and pressure at the hydrants.
- 8.93 Pipe couplings used with steel pipes shall be of a type that eliminates the need for pipe anchoring.
- 8.94 Ductile iron pipe shall be provided with spigot and socket joints.
- 8.95 Ductile iron pipe provided with spigot and socket joints shall be anchored at changes in direction and gradients.
- 8.96 Fire mains shall be protected against freezing in order that a supply of water for firefighting purposes is always available.
- 8.96.1 Frost protection should include thermal insulation of the main throughout the tunnel with trace heating 50 m in from each portal and at branches to the hydrants.
- 8.96.2 Outside the tunnel, no thermal protection may be necessary where the main is buried in ground at a depth of one metre or more.
- 8.96.3 When selecting the type of thermal insulation, the design should assess mechanical durability, rot and vermin protection.
- 8.96.4 The selected thermal insulation material should not give off toxic fumes if subject to fire.
- 8.96.5 Dry mains should be avoided where possible, as the time delay while the fire main charges can be unacceptable in emergency response conditions.
- 8.97 Corrosion protection shall be provided for all fire main pipes, joints, valves and pipeline equipment, with the addition of a polyethylene tubular film protective sleeving where the pipework and pipeline equipment is buried in the ground.
- 8.98 Section isolating valves shall be installed along the fire main within the tunnel for installation and maintenance purposes, at a minimum quarter distances along the fire main length.

8.99 Automatic air release valves shall be provided at locations best suited to release air accumulated within them fire main.

*NOTE Typically automatic air release valves are located at high points on a fire main.*

8.100 Drain down valves shall be provided to allow the fire main to be drained for maintenance or repair.

*NOTE Typically drain down valves are located at low points on a fire main and are connected to the tunnel drainage system.*

### **Automatic fire detection**

8.101 Where determined necessary by risk assessment, tunnel bores shall be provided with an automatic fire detection system, proven to be suitable for use in road tunnels, to give the tunnel operator the earliest possible warning of an occurrence of a fire in the tunnel.

8.102 The installed fire detection system shall accurately identify the location of a fire while minimising the time lapse between fire ignition and an alert being raised.

8.103 Automatic fire detection systems shall be designed to minimise the opportunity for false alarms to occur.

8.103.1 To avoid unnecessary closures all fire incident alerts should be reviewed and confirmed by a tunnel monitoring operative prior to the fire incident response plan being initiated.

8.104 An automatic fire detection alert received at the tunnel control centre shall cause CCTV or incident detection recording facilities to automatically activate so that a record of the alert condition can be stored for a short period before and then after the alarm.

*NOTE In a tunnel fire situation, the CCTV or incident detection recording can be replayed to permit the source of the smoke to be identified, even if the view of the location is subsequently obscured.*

### **Emergency doors and cross-passages**

8.105 Cross-passages shall be provided as outlined in Section 3, to assist in the safe evacuation of road users and to allow firefighting personnel access to the incident site.

*NOTE A typical cross-connecting door layout is shown in Figure 8.103N.*

Figure 8.105N Example of cross-connecting doors

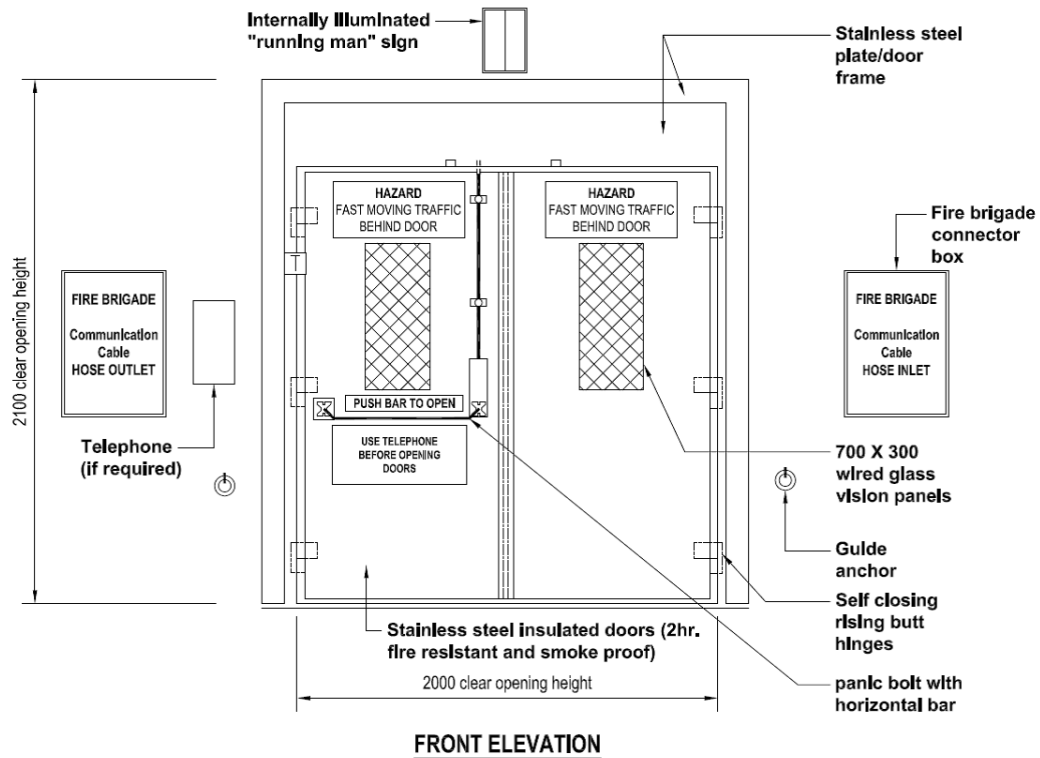
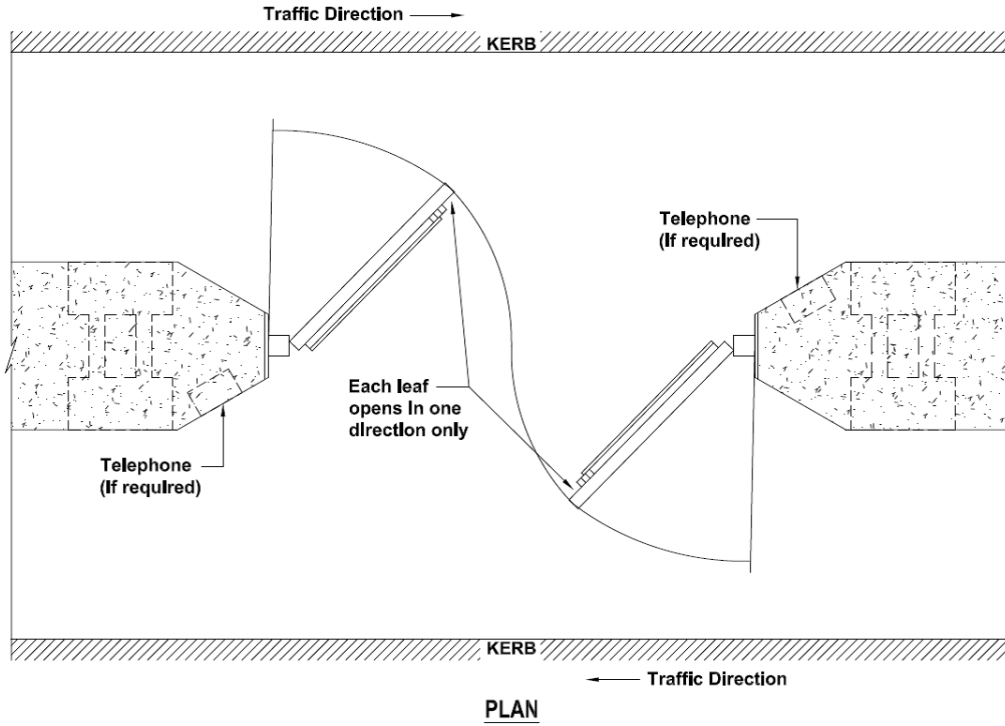

8.106 Cross passages shall be fitted with double-swing, self-closing emergency doors.

8.107 Emergency doors shall be a minimum of 914 mm wide.

- 8.108 Any passage or stairway associated with emergency doors shall have an unobstructed width of at least 1.12 m.
- 8.109 Emergency doors shall be constructed of a corrosion resistant grade of stainless steel suitable for use in the road tunnel environment and fitted with wired-glass vision panels to enable users to be aware of the traffic conditions on the opposite side.
- 8.110 The complete emergency door assembly including doors, frames and fittings shall be made from materials capable of 2-hour fire resistance.
- 8.111 Emergency doors shall fit such that smoke does not pass when closed.
- 8.112 Emergency door panic bars and release mechanisms shall be in accordance with BS EN 1125 [Ref 4.N].
- 8.113 Inter-bore fire hose connection pipes and communications ducts shall be provided at each cross passage door where required following consultation with local fire and rescue services.
- 8.114 The inter-bore fire hose connection pipes and communications ducts at each cross passage door shall be accommodated in cabinets constructed from corrosion-resistant stainless steel suitable for use in the road tunnel environment.
- 8.114.1 A cabinet used to accommodate the inter-bore fire hose connection pipes and communication ducts should be located on either side of the cross-passage door.
- 8.114.2 The inter-bore fire hose and communications pipe connections should be arranged so that they are effective from either carriageway with the female outlet always to the left when passing through the cross-passage doors.
- NOTE** *A cabinet used to accommodate the inter-bore fire hose connection pipes and communication ducts typically includes the following:*
- 1) *fire service compliant fire hose connections at each end of a fire hose connection pipe through the wall;*
  - 2) *male and female connectors on either side of the connection pipe;*
  - 3) *a hand control valve incorporated in the female coupling;*
  - 4) *siting of the inlet and outlet adjacent to the cross-passage door jambs, 200 mm to 600 mm to the side, and between 800 mm to 1000 mm from the verge;*
  - 5) *the inlet and outlet side conspicuously labelled (bi-lingual in Wales) "FIRE HOSE INLET" and "FIRE HOSE OUTLET"; and*
  - 6) *a 50-mm diameter communications cable duct.*
- 8.115 The following shall be provided in consultation with local fire and rescue services:
- 1) *recessed connections for breathing apparatus (BA) communications cable, (standards for these connections to be agreed with the fire and rescue service concerned to allow compatibility of equipment); and*
  - 2) *steel ring-bolts approximately 80 to 100 mm in diameter for use as BA guide line anchorage points, one on each side of the door in each bore and at locations along the tunnel walls agreed with the fire and rescue service(s), at a height of one metre above the verge.*
- 8.116 Emergency doors shall be designed to be clearly identifiable by all tunnel users at all times, and if necessary be guided towards them.
- NOTE 1** *Frequent tunnel users can note their existence and locations during their normal day-to-day use of the tunnel.*
- NOTE 2** *The attention of tunnel users can be drawn to the location of emergency doors by the use of conspicuous colour schemes or by the activation of additional static or dynamic lighting and/or sound beacons under evacuation conditions in accordance with BS EN 16276 [Ref 27.N].*

- 8.117 Cross passage door identification proposals shall be outlined within Approval in Principle documentation.
- 8.118 Each emergency door shall be identified by unique reference number clearly visible by CCTV (not shown in Figure 8.105N) to assist with determining its location in incident conditions.
- 8.119 The design of the doors shall be co-ordinated with tunnel operating procedures, emergency incident planning and other safety systems to minimise the risk of people using cross-passages and emerging into the path of moving vehicles in the unaffected bore.
- 8.119.1 Where deemed necessary, emergency doors may be controlled, that is, normally locked until traffic has been stopped and it is safe for evacuees to pass through.
- 8.119.2 Where emergency doors are controlled, an additional emergency telephone should be located adjacent to each controlled door to enable tunnel users reaching the door to request assistance. .
- 8.120 Opening of an emergency door shall cause an alarm to be raised at the tunnel control centre.
- 8.121 Emergency door monitoring equipment shall be of a type that does not give false signals when doors are subject to wind movement due to passing traffic.
- NOTE** *Tunnel fire incident response planning often includes closing of the road tunnel to traffic in each direction of operation, (that is each bore of a twin-bore tunnel), as a primary response action in order to maximise the safety of tunnel users accessing inter-bore emergency doors.*

### **Emergency exit signage ('wayfinding signs')**

- 8.122 On all uncontrolled escape routes and exits permanently illuminated signing shall be provided to indicate the way out of the tunnel in the event of an emergency.
- 8.123 Emergency exit signage lighting shall be maintained for a minimum period of 2 hours in the event of failure of the normal power supply.
- 8.124 Emergency signs shall be in accordance with BS 5499-4 [Ref 63.N] and BS EN 1838 [Ref 44.N].
- 8.125 Emergency exit door signage shall be located centrally above every emergency exit door and be visible through 180° horizontally to indicate the location of the door.
- 8.126 Emergency exit door signage projecting from the wall shall be mounted at a height to the underside of not less than 2.3 metres.
- 8.127 Emergency exit wall signage shall be located at intervals of not more than 25 metres along the walls on both sides of the carriageway, to indicate the distance to the nearest exit in either direction in yards.
- 8.128 The front faces of the emergency exit wall signs shall be flush with the surface of the wall finishes.
- 8.129 Emergency exit wall signs shall be as shown in UKSI 2016/362 (TSRGD) [Ref 78.N].
- 8.130 Emergency exit wall signs shall be mounted at a height of between 1.0 and 1.5 metres to the centreline.
- 8.131 Symbol heights used for emergency exit signs shall be determined according to the maximum viewing distance, using the method described in BS EN 1838 [Ref 44.N].
- 8.132 The mean luminance of the white contrast sections of internally illuminated signs shall be 100 cd/m<sup>2</sup>.
- 8.133 Externally illuminated signs shall be lit to a minimum vertical illuminance of 10 lux.
- 8.134 On controlled escape routes and exits, variable message signs or secret-until-lit signs shall be used.
- 8.135 Controlled escape routes and exits signs shall only be activated when it has been verified that the route is available and safe to be used but in all other respects are as defined above for uncontrolled escape routes.
- 8.136 When dynamic emergency exit lighting is to be utilised the emergency exit lighting control system shall be designed in accordance with the procedures outlined in BS EN 50172 [Ref 22.N]/ BS EN 50172, BS 5266-8 [Ref 21.N] and BS EN 61508-2 [Ref 35.N].

## Evacuation lighting

- 8.137 In all Trans-European road network tunnels, evacuation lighting must be provided to mark the location and direction of available escape routes, in accordance with the Road Tunnel Safety Regulations UKSI 2007/1520 [Ref 77.N].
- 8.138 Evacuation lighting provision shall be in accordance with the principles given in BS EN 16276 [Ref 27.N].
- 8.139 Additional lighting shall be provided to highlight the locations of emergency exit doors (if available for use).
- 8.140 Power for emergency lighting shall be derived from a maintained emergency supply with a minimum duration of 2 hours in the event of failure of the normal power supply.
- 8.141 Facilities shall be incorporated within all evacuation lighting to allow monitoring of the status of each lighting circuit by the plant monitoring and control system, either directly or via an evacuation lighting control system.
- 8.142 Where evacuation lighting is not permanently lit it shall be illuminated by the control system upon entering an "incident mode" or following a failure of the control system.
- 8.143 The evacuation lighting control system shall be designed in accordance with the procedures outlined in BS EN 50172 [Ref 22.N] BS EN 50172, BS 5266-8 [Ref 21.N] and BS EN 61508-2 [Ref 35.N].

## Service buildings and plant rooms

### General

- 8.144 All buildings and ancillary structures shall be zoned and provided with one or more fire alarm systems in accordance with BS EN 54 [All parts] [Ref 29.N].
- 8.145 Where service buildings and plant rooms or areas are not manned, automatic fire detectors shall be provided and monitored remotely, both for immediate detection and location of the fire and for fault detection.
- 8.146 Means of escape and fire extinguishing equipment and systems shall be provided in buildings and structures in accordance with relevant fire safety regulations and local fire authority requirements.
- 8.147 Where provided, portable fire extinguishers shall be located in accordance with BS 5306-3 [Ref 30.N].

### Fixed gas discharge extinguisher systems

- 8.148 Fixed fire fighting protection shall be installed to all plant areas containing electrical switchgear, communications and control equipment, and generator plant.
- 8.149 Fixed fire fighting systems shall be provided in accordance with BS EN 12094 [All parts] [Ref 33.N].
- 8.149.1 Fixed fire protection options should be evaluated at the design stage, considering performance, environmental and health issues, availability and fire authority approvals.
- 8.150 An electro-mechanical lock-off to prevent the automatic release of CO<sub>2</sub> by automatic sensing units shall be provided in all areas protected by total flooding CO<sub>2</sub> systems that are to be occupied even for short periods.
- 8.151 Rooms protected by gaseous extinguishers shall be completely sealed to sustain room pressures compatible with the extinguishing system.
- 8.151.1 The extinguisher system design should be co-ordinated with the structural and architectural design to so that the room and all relevant doors, windows, dampers, and similar opening enclosures are capable of withstanding and containing any elevated pressure due to release of the extinguishant.
- 8.152 Top-up facilities shall be provided for the interim period of repair if a room leakage path occurs.
- 8.153 Rooms protected by fixed firefighting discharge extinguisher systems shall be equipped with ventilation equipment to clear the extinguishant and products of combustion before the room is re-entered.

- 8.154 Activation of any fixed gas discharge extinguishing systems shall cause an alert to be raised at the tunnel control centre.

### **Tunnel drainage sumps**

- 8.155 Fixed fire fighting protection shall be installed to all drainage sumps within the confines of a tunnel or having a direct connection to the tunnel carriageway drainage system.
- 8.156 Fixed fire fighting systems shall be capable of preventing any risk of ignition or explosion resulting from the presence of flammable liquid or vapour.
- 8.157 Fixed fire fighting systems shall be capable of extinguishing a fire in the sump if it occurs.
- 8.158 Sumps shall be provided with detectors for heat, hydrocarbon gas and oxygen deficiency to initiate protective action in the event of a hazardous spillage.

*NOTE Liquids spilt on the road surface can, on occasions, give rise to an explosive and/or flammable atmosphere in a sump.*

- 8.159 All electrical equipment within a sump shall be ATEX Directive 2014/34/EU and the CE marking compliant of a type specifically designed for use in an explosive or flammable environment.

*NOTE Section 7, provides guidance on tunnel spillage conditions and sump related equipment.*

- 8.160 Fire fighting systems shall be capable of automatic discharge following detection of a combustible gas, heat, or similar hazard or be capable of remote manual discharge.
- 8.161 Where an automatic foam system is proposed the foam shall be compatible with any foam used by the associated fire and rescue service.
- 8.162 Where an automatic foam system is proposed a dry inlet shall be provided for the remote application of additional foam to top up the foam blanket by the fire and rescue service. .
- 8.163 Where an oxygen depletion system is proposed it shall reduce the concentration of oxygen within the sump to below the minimum level that can support combustion using either direct removal of the oxygen from the sump atmosphere or by the injection of nitrogen or other inert gas, to dilute the overall oxygen content.
- 8.164 All gas bottles supporting drainage sump firefighting systems shall be located so as to be readily accessible for inspection, maintenance, repair, exchange, refilling or topping up of contents, with minimal impact on tunnel operation.

## 9. Traffic control, communications and information systems

### General

- 9.1 Traffic control and information systems shall be designed to meet the design and authorisation criteria for the normal day-to-day or emergency incident operating conditions.
- NOTE Reference to tunnels includes the approach and exit roads coming within the limits of the operating regime for the tunnel that have been jointly agreed between the design organisation and authorities responsible for traffic control, maintenance and operation requirement.*
- 9.2 The provision of traffic control, communications and information systems and competent staff to operate them, shall form part of the safety measures required for the tunnel.
- 9.3 The traffic, communications and information systems shall be based on the infrastructure, operation, users and vehicles.
- 9.4 Signs, signals, incident detection systems, barriers and all other traffic monitoring and control equipment associated with a tunnel shall be monitored and controlled through systems with SIL determined in accordance with General design part of this Section.
- NOTE For existing tunnels, control of signs, signals, incident detection systems, barriers and all other traffic monitoring and control equipment has typically been achieved via the tunnel SCADA system without compliance with BS EN 61508 [All Parts] [Ref 36.N].*
- 9.5 Tunnel monitoring and control shall take place from a remote traffic control centre (TCC), not inside the tunnel or within radius of the portals.
- 9.6 A local human/machine interface (HMI) shall be provided in the tunnel service building for local control of signs and signals.
- 9.6.1 The local HMI may be used during maintenance activities.
- 9.6.2 The local HMI may be used if the TCC is unavailable.
- 9.7 Facilities for traffic management and tunnel communication shall be integrated with the operation of systems installed to monitor and control the tunnel environment.
- NOTE 1 Integrating facilities for traffic management and tunnel communications is to achieve appropriate levels of safety over the full range of operating conditions.*
- NOTE 2 Monitoring of traffic and other activities is achieved by a range of manual and automated systems which can include visual observation, closed circuit television (CCTV) viewed on monitors, automatic incident detection, vehicle detection through loops or various forms of above ground detection and verbal communication via emergency telephones, maintenance radio or cellular radio.*
- 9.8 When hazards arise, variable signalling used to control traffic shall display authorised warnings to slow or redirect traffic or warn of lane closures.
- NOTE Traffic is controlled by a combination of variable message signs (VMS), matrix signals and portal/lane control signs, according to specific needs.*
- 9.9 System design shall be related to the layout of the tunnel and its safety facilities, e.g. emergency points and escape routes.
- 9.10 Equipment shall be located outside the traffic gauge.
- 9.11 Locations of equipment shall be selected in order to minimise the mean time to repair that equipment.
- 9.12 All systems shall have remote fault diagnostics facility.
- ### Connection to remote traffic control centres
- 9.13 Tunnel traffic control, communications and information systems shall be designed for connection to a centralised remote monitoring and control centre.

*NOTE* Connection to a centralised remote monitoring and control centre is conventionally achieved via the tunnel SCADA system.

9.14 The tunnel traffic control, communications and information systems shall transmit data to the TCC.

9.14.1 The transmitted data can create actions and may require operator intervention.

9.14.2 Remote HMIs for tunnel operation and maintenance may be connected to the tunnel systems via the external network.

### General design

9.15 Equipment shall be designed to achieve a mean time between failures that is aligned with maintaining minimum operating requirements and the route availability target.

*NOTE* Road tunnels present a hostile environment for equipment, with dust, vehicle pollution, corrosive substances and wind pressure from passing vehicles amongst other factors.

9.16 All systems used in the detection and response to incidents and emergencies shall be treated as life safety systems.

9.17 All life safety systems shall have their associated risks assessed and equipment designed in accordance with BS EN 61508-2 [Ref 35.N].

9.18 Tunnel monitoring, control and communication systems shall be designed based on a risk assessment.

9.19 Tunnel monitoring, control and communications systems shall be designed and functions integrated to appear from the control room operator's perspective to operate as a single system through a single HMI.

*NOTE* HMI equipment working in main and standby modes is often to ensure operational availability.

9.20 The electrical power supply systems shall be designed with fault resilience to ensure that no failure mode, or combination of failures, result in loss of power to life-safety systems.

9.21 The TCC shall be ergonomically designed to enable:

- 1) efficient operation of the tunnel during day-to-day operations;
- 2) efficient operation of the tunnel in the event of an incident; and
- 3) incorporation of best human factor practice, to minimise errors by operators.

9.22 The communications equipment room(s) at the TCC shall be laid out such that maintenance staff can access the equipment, without undue delay, restriction or inconvenience, for routine maintenance and repair work.

9.23 All cables shall be terminated on a labelled distribution frame secured against unauthorised access.

9.24 The equipment room environmental conditions shall be controlled to ensure correct equipment performance.

*NOTE 1* Vibration, humidity or temperature extremes can affect performance.

*NOTE 2* Environmental parameters in the equipment room(s) that need to be controlled include temperature, humidity and dust.

9.25 The equipment room(s) shall be secured against unauthorised access.

9.25.1 For some tunnels, additional equipment rooms and/or equipment cabinets, located outside the tunnel may be necessary.

9.26 Additional equipment rooms shall be designed according to their locations to withstand the more hostile environment for cabinets near or within tunnels.

9.27 Where control equipment is located within the tunnel it shall be co-located in a fire-protected location segregated from other services.

**NOTE** *It is common practice to provide additional compartments for this purpose within emergency panels (EP) or electrical distribution panels (EDP).*

9.28 The design of cabinets shall include segregation between different systems for reasons of:

- 1) fire integrity;
- 2) electrical safety during maintenance;
- 3) operating resilience; and
- 4) security.

9.29 For cabinets a local, secure power supply isolation facility for maintenance purposes shall be provided.

9.30 Facilities shall be provided for power and communications cabling to all signalling, from power supply points and the main communication cabinets.

### **Communications infrastructure and cabling**

9.31 Communications shall be included as a part of the traffic, communications and information systems.

9.31.1 As communications provision evolves, suitable alternative means of communication may emerge.

**NOTE** *Highway tunnel systems connect between the tunnel service building (TSB) and the TCC via the highly resilient network system (HRNS) can be based as far as possible on the local national roads telecommunications services network.*

9.32 Additional network capacity, shall be provided to allow for future expansion.

9.33 The network capacity shall allow for at least 25% unused cores or fibres in all network cables.

9.34 At least one spare duct of the same size as those used for network cable installation shall be provided.

9.35 At least one spare tray of the same size as those used for network cable installation shall be provided.

**NOTE** *Communications between central equipment in the TSB and tunnel monitoring, control and communication devices can be either by copper or fibre cables and can utilise data networks carrying other services or using wireless communications.*

9.35.1 In tunnels less than 1 km in length cables may be run straight through ducts to the equipment within the tunnel (such as for telephones and cameras).

9.36 In tunnels greater than 1 km in length, cables shall be run to one or more cabinets, where the cables are terminated and distributed to the adjacent areas.

9.37 Routes for multipair copper and associated communications power cables in a tunnel shall be designed to eliminate any risk of interference from:

- 1) power cables; and
- 2) other M&E equipment in the tunnel.

9.38 Communications cables shall be segregated from electricity supply cables, other than those supply cables associated solely with the communications system, to avoid the risk of mechanical damage and electrical interference.

### **Emergency telephone system**

9.39 Emergency telephones shall be provided for tunnel users to communicate with the TCC in an emergency such as a vehicle breakdown or fire.

9.40 Emergency telephones shall be provided in the following situations:

- 1) within each emergency panel;
- 2) adjacent to controlled emergency doors;
- 3) in smoke control panels;

- 4) for new tunnels, externally near the portal and inside at intervals not exceeding 150 m and, for dual carriageway roads, accessible from either carriageway; and
- 5) for existing tunnels, externally near the portal and inside at intervals not exceeding 250 m and, for dual carriageway roads, accessible from either carriageway.

- 9.41 Emergency telephones shall be installed so that they can be accessed safely.
- 9.42 Additional emergency telephones shall be provided in adjacent lay-bys or locations where stationery vehicles, large loads or hazardous loads require special attention such as recovery, inspection or escort.
- 9.43 Access to emergency telephones for public use must be assessed under the Equality Act UKPGA 2010/15 [Ref 24.N].
- 9.44 Signs within the tunnel shall be provided to allow road users to locate an emergency telephone.
- 9.45 Emergency telephones shall be designed in accordance with DMRB document TD 131 [Ref 61.N].
- 9.45.1 The telephones should suit the hearing and visually impaired.
- 9.46 Alternate emergency telephones within the tunnel control area shall be served from network connection points in alternate directions.

*NOTE Network connection points reduce the probability that adjacent emergency telephones can be faulty due to shared equipment or cables.*

### **Radio rebroadcast systems**

- 9.47 Tunnels shall be provided with means of maintaining radio communication for emergency services and maintenance staff.
- 9.48 Radio communication for emergency services and maintenance staff shall provide both data and speech connectivity.
- 9.48.1 Radio rebroadcast systems should be provided, to ensure radio coverage within the tunnel.
- 9.48.2 Radio transmission systems within a tunnel may need approval of the Office of Communications (OFCOM) and an appropriate licence.

*NOTE 1 The RTSR UKSI 2007/1520 [Ref 77.N] mandates a radio rebroadcast system for emergency services in certain tunnels.*

*NOTE 2 Most tunnels are equipped with a common radio transmission service provided by airwave using terrestrial trunked radio (TETRA) equipment for use by emergency services.*

*NOTE 3 The airwave radio service using TETRA is scheduled to be replaced by the emergency services network (ESN).*

- 9.49 The tunnel traffic system design shall include provision for the infrastructure equipment for the ESN as part of any radio rebroadcast system.

- 9.50 Where public service radio rebroadcast is provided a radio 'break-in' facility shall be provided.

### **Public address voice alarm systems (PAVA)**

- 9.51 The quality and volume of the PAVA system shall be such that announcements are audible and intelligible at ambient sound levels.
- 9.51.1 Use of the PAVA system should be integrated with use of any emergency messages broadcast via radio break-in systems in the tunnel.
- 9.51.2 In order to achieve acceptable intelligibility, the public address system should be capable of producing at least 6 dBA more sound power level than the background noise.

- 9.52 The levels of ambient background noise under which the PAVA system is required to be intelligible shall be measured as an LA10 over a 24-hour period on at least one occasion and published for the benefit of the sound system (electro-acoustic) design.
- 9.53 The ambient sound level shall be measured in a bore of the tunnel.
- 9.54 The ambient sound measurement in the bore of the tunnel shall include a period when it is full with stationary vehicles with their engines running and with the ventilation system running on full power.
- NOTE To achieve acceptable test ambient noise test conditions, the period of measurement can be planned to include times when it has been historically proven that peak conditions could be expected to exist.*
- 9.55 The sound system (electroacoustic) design shall be based on the details of the tunnel geometry and finishes of primary surfaces.
- NOTE Knowledge of the primary surfaces allows the prediction, via acoustic modelling, of various electro-acoustic designs to determine which is the optimum solution.*
- 9.55.1 For a new tunnel, the levels of ambient sound may be estimated by taking measurements of ambient sound in a comparable tunnel and extrapolating.
- 9.56 PAVA systems shall be equipped to:
- 1) broadcast either pre-recorded or live messages; and
  - 2) record and time-stamp details of all messages broadcast.
- 9.57 A suite of messages that covers the most likely emergency scenarios shall be made available either on cue cards for live messages, or pre-recorded.
- NOTE In an emergency situation, it can be difficult for a tunnel control operator under pressure to deliver clear and concise messages, or, continually repeat them.*
- 9.58 The public address system shall be designed to achieve a speech transmission index (STI) of 0.5 or better, in accordance with BS EN IEC 60268-16 [Ref 67.N].
- 9.59 In some reverberant tunnels an STI of 0.5 can be difficult to achieve and in such instances an acceptable level of intelligibility shall be assessed subjectively by a listening panel representative of tunnel users.
- NOTE 1 General information and guidance on the recommended content of emergency messages can be found in the PIARC Technical Report R17 [Ref 39.N].*
- NOTE 2 Subjective assessment of STI is dependent on message complexity.*
- 9.59.1 Concise messages may need to be used in some instances to achieve the required STI of 0.5, as recognised in BS EN IEC 60268-16 [Ref 67.N].
- 9.60 At least one microphone for live messages shall be provided at the TCC.
- 9.60.1 Slave microphones may be provided, for use by the Fire and Rescue Service (FRS) in the tunnel smoke control panels.
- 9.61 Active or passive noise-cancelling microphones shall be used in tunnel smoke control panels.
- 9.62 Tunnel smoke control panels shall be located so that the microphone faces away from the carriageway.
- 9.63 The tunnel PAVA system shall permit announcements to be made independently to the following areas:
- 1) each tunnel bore and associated public areas;
  - 2) external areas at each end of the tunnel; and
  - 3) non-public areas.
- 9.63.1 Public address zones may be provided for technical or operational reasons.
- 9.63.2 Where specific public address zones are utilised during normal operations and emergencies the effects of sound bleed outside the selected zone should be mitigated in the system design.

## Signs and signals

- 9.64 Signs and signals shall be provided to actively direct and/or advise road users.
- 9.64.1 The VMS, portal/lane control signals and motorway matrix's displayed legend and any associated red or amber lamps should be legible to drivers in the lanes to which the message is directed, for a minimum period of 4 seconds.
- 9.64.2 The calculation of legibility, assuming driver eye height of 1.2 m, should be in accordance with Annex N of BS EN 12966 2014+A1:2018 [Ref 83.N].
- 9.64.3 The permitted beam width of such signs, signals and lamps should be in accordance with UKSI 2016/362 (TSRGD) [Ref 78.N].
- NOTE* Conventional motorway and trunk road communication systems, such as NMCS2, are deemed to be advisory, and are therefore neither designed nor maintained as safety critical or safety related systems.

## Variable message signing

- 9.65 Variable message signs shall be provided as required by the tunnel risk assessment.
- NOTE 1* Variable message signs (VMS) could be used to provide traffic management instructions for predictable situations which affect traffic flow, to sign diversionary routes and to improve compliance with other signals.
- NOTE 2* VMS consist of either:
- 1) Fixed text message signs (FTMS), which include hidden message signs and rotating prism signs. They can display a limited number of predefined messages or a blank face. They can be used to display any sign in the UKSI 2016/362 (TSRGD) [Ref 78.N] and can change the information on direction signs; or
  - 2) Enhanced message signs (EMS), which have a matrix of light emitting elements that can display a wide variety of messages in a limited range of colours.
- NOTE 3* VMS displays can be appropriate where it is necessary to regulate traffic in the event of routine maintenance or emergency tunnel closures.
- 9.65.1 FTMS and EMS may be used to enhance signalling during emergencies.
- 9.66 VMS shall be controlled and monitored from the TCC.
- 9.67 Where VMS units are required to have flashing amber lanterns, they shall be synchronised between VMS units viewable from one location.
- 9.68 Where there are matrix type signals, within 100 m viewable at the same time, VMS flashing amber lanterns shall be synchronised between VMS units and the matrix signals.

## Portal/lane control signals

- 9.69 Static advice signs shall be provided to describe to drivers what portal/lane control signals mean.
- 9.70 Control signals sited in the tunnel shall be located centrally over each lane.
- NOTE* Where required, traffic light signals can be an alternative to lane portal signals.
- 9.71 Control signals shall be visible over a range of 500 m through the tunnel.
- 9.72 Control signals and equipment shall not encroach beyond the equipment gauge.
- 9.72.1 Matrix type signals should be considered initially, to provide the capability to display new legends without the need to replace hardware.
- NOTE* Details of Matrix type control signals are given in Schedule 10 of the UKSI 2016/362 (TSRGD) [Ref 78.N].

- 9.73 Where contraflow is to be operated, signals shall be mounted at the entrance and exit of each bore along with traffic detectors.
- 9.73.1 Lane control signals within the tunnel should be mounted back to back.
- 9.74 Provisions for signs and signals shall be according to the type of tunnel.
- 9.75 All tunnels shall be equipped with portal/lane control signals to enforce closures.
- 9.76 Portal/lane control signals shall be capable of displaying lane closed (red cross) and lane open (green arrow) to separately control traffic in each running lane.
- NOTE To reduce visual clutter in the tunnel and improve the driving experience, it is permitted to not display the green arrow on portal/ lane control signals during normal operation, showing a blank face instead is acceptable.*
- 9.77 Portal/lane control signals shall be locally hardware interlocked to ensure that lane open arrows cannot be displayed simultaneously on both forward and rearward faces.
- 9.77.1 VMS may be provided at the tunnel portals to provide the road user with additional information explaining the reason for any closure.
- NOTE Such VMS can have messages such as: 'tunnel closed' with relevant text; 'accident', 'fire', 'traffic fumes' etc. to attempt to improve driver compliance with control signals.*
- 9.78 Two-way tunnels and all dual carriageway and motorway tunnels shall have lane control signals mounted centrally above the running lanes within the tunnel.
- 9.79 For all tunnels, gantry mounted signs and signals shall be provided in advance of the tunnel, before the last traffic divergence point for an alternative route.
- NOTE Gantry mounted signs and signals can be used to warn approaching drivers that the tunnel is restricted or closed and provide the opportunity to use a signed alternative route.*
- 9.79.1 Alternative solutions should be developed for tunnels without the provision of gantries.
- 9.80 All VMS signs and signals shall be interlocked by hardware, software or a combination of both to prevent displaying conflicting information.
- 9.81 Portal/lane control signals shall be isolatable to be as far as possible external from the tunnel envelope i.e. not in the cross passages or at the sign itself.
- NOTE Where a fault develops, a portal/lane control signal which is isolatable can be taken out of service without undue impact on operation of the tunnel.*

### **Motorway matrix signals**

- 9.82 Motorway tunnels shall be provided with VMS:
- 1) where overhead lane signalling is required to be used for contraflow; and
  - 2) where the approaches to tunnels are subject to restricted access.
- 9.83 The provision of signals on motorways shall apply to tunnels and their approach roads.
- 9.84 The indicator legends and their flashing lanterns shall be legible at 300 m and 500 m, respectively.
- NOTE Alignments of tunnels and their approach roads can differ from open motorways.*
- 9.85 Signals shall be sited to be visible over a range of 500 m through the tunnel.

### **Tunnel closures systems**

- 9.86 Signs and signals provided for enforcing tunnel closure shall take account of the road type and signed speed limit.
- NOTE Operational experience indicates road users show better rates of compliance with RAG signals than wigwags.*

- 9.86.1 Stop signals should be located close to the tunnel entrance portal to limit the number of vehicles between the signal and the portal that continues to enter the tunnel in an emergency closure.
- 9.86.2 To minimise the numbers of vehicles stopped on the tunnel approach, additional VMS should be installed on roads approaching the tunnel, to direct traffic onto alternative routes.
- 9.86.3 The portal signalling should be supplemented with upstream signs or signals or signals that communicate to road users the need to stop ahead, and to expect stopped vehicles ahead.
- NOTE 1 Road users are anxious about being the first to come to a halt on a high-speed road where no junction is signed or expected.*
- NOTE 2 Wherever physical barriers such as rising arm barriers are installed, they can be deployed to prevent vehicles from entering a tunnel during a closure.*
- NOTE 3 The use of signals alone to enforce tunnel closure allows the risk of road users choosing to ignore the instruction and continuing into the tunnel, with the consequent risk of danger to themselves or others.*
- 9.86.4 The design of physical barriers should include the following:
- 1) means of ensuring that all approaching traffic has stopped and the road between the stop signals and the barrier is clear before operating the barrier;
  - 2) safeguards to prevent unintentional operation of the barrier in either state;
  - 3) provision for local manual operation by the emergency services to allow their vehicles to enter; and
  - 4) provision to ensure that vehicles and pedestrians can always exit the tunnel safely.

### **Illuminated lane markers**

- 9.87 Where identified by the risk assessment process described in this section, internally illuminated lane markers shall be provided.
- 9.87.1 It may be desirable to install internally illuminated lane markers to supplement, or replace, the normal reflective lane delineation studs, for enhanced visibility and guidance to drivers.

### **Automatic incident detection systems**

- 9.88 Automatic incident detection systems shall be fitted in any tunnel with a control centre to which the RTSR applies in accordance with the RTSR UKSI 2007/1520 [Ref 77.N] .
- NOTE Automatic incident detection systems use a range of technologies to detect abnormal traffic movements.*
- 9.89 All tunnels with a control centre shall be fitted with an automatic incident detection system for detecting the following events:
- 1) slow-moving traffic (less than 20 mph);
  - 2) traffic queues;
  - 3) individual stopped vehicles;
  - 4) vehicles travelling in the wrong direction;
  - 5) pedestrians; and/or
  - 6) debris in the carriageway.
- 9.90 An automatic incident detection system shall have the facility to raise an alarm when an event is detected, and to immediately replay a stored CCTV scene of the incident covering the period from 15 seconds before the detection to 60 seconds after incident end.
- 9.91 Systems selected for installation shall be based on the operational performance in terms of:
- 1) detection rate;

- 2) detection time;
- 3) false alarm rate; and
- 4) whole life costs.

- 9.91.1 All events captured by the automatic incident detection system, whether false alarms or genuine, should be stored automatically for subsequent retrieval and analysis.
- 9.92 The automatic incident detection system shall detect a minimum of 80% of incidents (as measured over a minimum of 10 consecutive real-life events in the same tunnel) that happened within the maximum detection time.
- 9.93 The automatic incident detection system shall have minimum of 98% system and service availability.
- 9.94 The automatic incident detection system shall have a maximum four minute detection time (as measured over a minimum of 10 consecutive real-life events in the same tunnel).
- 9.95 The automatic incident detection system shall have a false alarm rate of less than 1 per 8 hours (as measured over 30 days).
- 9.96 The automatic detection incident system shall cover the entire tunnel length and, at intervals of 100 m.
- 9.97 Where contraflow is used during maintenance operations, the incident detection system shall operate for both directions.

### **Closed-circuit television (CCTV)**

- 9.98 CCTV shall be fitted in any tunnel with a control centre.
- 9.99 CCTV shall be installed to provide coverage at the following locations:
- 1) inside the tunnel;
  - 2) outside of each portal; and
  - 3) on the approaches/exits.
- NOTE* *Vegetation growth at the portals and approaches can obscure the coverage.*
- 9.100 CCTV shall be mounted above the traffic envelope.
- 9.101 The CCTV system shall provide 100% coverage of public areas to a height of at least 3 m such that a person occupies at least 10% of the screen height.
- 9.102 The CCTV shall be able to read a number plate in any public area.
- 9.103 Potential invasion of privacy shall be mitigated at all cameras sites. .
- 9.104 All cameras shall be provided with pan, tilt and zoom (PTZ) and weatherproof housings.
- NOTE* *The cleaning frequency of camera lenses can depend on the level of soiling.*
- 9.104.1 Cameras should be provided with wash wipe facilities.
- 9.104.2 Camera wash bottles should be located so that they can be accessed during tunnel maintenance.
- 9.104.3 Camera wash bottles should hold sufficient washer fluid to clean the camera lens between maintenance cycles.
- 9.105 Provision shall be made for all local camera cabling and cable junction boxes.
- 9.106 Local camera cabling and cable junction boxes shall be housed in emergency panels.
- 9.107 The CCTV system shall interface with the following:
- 1) other tunnel systems;
  - 2) TCC; and
  - 3) other CCTV systems which the administration authority may operate.

- 9.108 CCTV monitors shall be provided to enable the tunnel operators to observe each CCTV camera view.
- 9.108.1 The provision of monitors that can sequentially scan the cameras on a regular basis may be used.
- 9.109 The CCTV system shall have minimum 99% system availability.
- 9.110 The CCTV system shall have minimum 98% service availability.

### **Traffic monitoring and vehicle detection**

- 9.111 Where the tunnel risk assessment determines that traffic monitoring and detection equipment is required, it shall be provided.
- 9.112 Where traffic monitoring and vehicle detection equipment is required it shall provide:
- 1) a continuous count of the number of vehicles per hour in each lane;
  - 2) classification of counted vehicles in speed bands; and
  - 3) classification of vehicles by type, i.e. by number of axles and/or by length and/or weight.
- 9.113 The performance requirements in terms of availability and accuracy shall be as specified by the tunnel risk assessment.
- 9.114 Vehicle detection loops shall not be provided within the tunnel.
- 9.115 Where above road vehicle detection systems (infra-red, laser, microwave, CCTV image processing etc.) are used, they shall not interfere with the operation of any other tunnel system.
- NOTE 1* *Infra-red, laser, microwave and CCTV image processing vehicle detection systems are gantry mounted, they do not involve disruptions to the carriageway surface.*
- NOTE 2* *Video-based systems exist that can read hazchem plates and record the passage of vehicles carrying dangerous goods.*
- NOTE 3* *Video-based systems can be used to segregate such vehicles in order to escort them through the tunnel or reroute them.*

### **Over-height vehicle detection**

- 9.116 An overheight vehicle detection and warning system shall be provided for tunnels whose maintained headroom does not comply with Section 4 of this document.
- 9.117 The location of the detection equipment shall be sufficiently in advance of the tunnel to enable a minimum of two warning signs or messages to be displayed to drivers, in order to allow them to stop at a designated location or divert before they reach the tunnel portal.
- 9.118 The location shall:
- 1) be clearly signed;
  - 2) provide a parking location clear of the running lanes of suitable size for an HGV;
  - 3) have an emergency telephone with direct connection to the TCC; and
  - 4) have provision to either:
    - a) enable the over-height vehicle to be escorted off the carriageway; or
    - b) enable the over-height vehicle to be escorted through a suitable bore if one exists.
- 9.119 Systems selected for installation shall be based on the operational performance in terms of the following:
- 1) detection rate;
  - 2) detection time;
  - 3) false alarm rate; and
  - 4) whole life costs.

- 9.120 The overheight vehicle detection and warning system shall have minimum 99% system availability.
- 9.121 The overheight vehicle detection and warning system shall have minimum 98% service availability.
- 9.122 The overheight vehicle detection and warning system shall have not less than 95% detection of overheight vehicles.
- 9.123 The overheight vehicle detection and warning system shall have not more than a 1% false alarm rate for vehicles less than 1 m under the target height.
- 9.124 The overheight vehicle detection and warning system shall have not more than a 0.01% false alarm rate for vehicles more than 1 m under or above the target height.
- 9.125 The overheight vehicle detection and warning system shall have not more than a ten second detection time.

### **Speed enforcement**

- 9.126 An assessment shall be carried out to determine the risk of speed non-compliance and the likely effect of such non-compliance.
- 9.127 Where the assessment determines the likely effect of speed non-compliance is unacceptable, measures shall be taken to reduce the risk to an acceptable level.
- 9.127.1 A measure to reduce the risk of speed non-compliance may be the use of speed enforcement cameras.
- NOTE The use of speed enforcement cameras and variable speed limits in tunnels has been demonstrated to achieve a significant reduction in speed-related accidents while also improving throughput.*
- 9.127.2 Single-point cameras should not be used to enforce speed limits within a tunnel.
- NOTE Single point cameras create a hazard associated with vehicles suddenly slowing when a camera is seen by the driver.*
- 9.127.3 A distributed average speed system that measures the time taken for a vehicle to pass between two successive live cameras should be used to enforce speed limits within a tunnel.
- 9.127.4 Distributed average speed camera systems may allow cameras to be located outside the tunnel where access for maintenance can be easier.

## 10. Plant monitoring and control

### General requirements

10.1 The plant monitoring and control system (PM&CS) architecture shall be determined by the following factors:

- 1) safety requirements;
- 2) system complexity;
- 3) required reliability, fault resilience and/or availability;
- 4) other tunnel systems present e.g. traffic control, traffic monitoring, etc.;
- 5) requirements for communications with remote control centres; and
- 6) other local requirements.

10.1.1 The PM&CS should consist of the following elements:

- 1) field instrumentation and equipment;
- 2) outstations containing either distributed control programmable logic controllers (PLC) or remote input/output (I/O) modules communicating with the central PLCs;
- 3) central PLCs;
- 4) supervisory, control and data acquisition (SCADA) servers; and
- 5) operator's and maintainer workstations or human / machine interfaces (HMI).

### Safety integrity level

10.2 One of the first stages of the design process shall be to determine the appropriate safety integrity level (SIL) for the various life safety functions.

*NOTE The process for design development of systems with a SIL requirement is outlined in BS EN 61508 [All Parts] [Ref 36.N].*

10.3 A SIL determination report shall be published based upon the findings of a hazard identification process.

*NOTE Hazards to be identified are those that present a risk of harm to tunnel users, operational and maintenance staff or the environment introduced by the presence and operation of the tunnel.*

10.3.1 The hazard identification process should involve input from relevant stakeholders, including members of the tunnel design and safety consultation group (TDSCG).

10.4 Assessment of the reliability of all parts of the PM&CS system shall include assessment of the reliability of all associated systems upon which they depend for their correct operation, such as uninterruptible power supplies and heating, ventilation and air conditioning (HVAC) plant.

10.5 Where a SIL is applied to the PM&CS a SIL verification report shall be produced prior to project completion, by an independent third party, demonstrating adherence to BS EN 61508-2 [Ref 35.N].

### System architecture

10.6 The PM&CS equipment shall be designed for a minimum 20-year service life.

10.7 To prevent system faults from causing a deterioration of the monitoring or control functionality, the PM&CS system shall be designed with a high level of fault resilience, reliability and availability, formulated as part of the overall tunnel availability target and in line with the requirements derived from the SIL determination report.

10.8 The PM&CS design shall demonstrate that non-safety functions cannot adversely affect safety functions under both normal operating conditions and component failure modes.

- 10.9 Hazard analysis and risk assessments shall be undertaken in line with current or proposed emergency operating procedures.
- 10.10 The PM&CS equipment shall be modular in fashion to permit the cost-effective replacement of failed components and to permit possible future upgrades and enhancements without the requirement to replace the system in its entirety.
- 10.11 The PM&CS equipment shall be formed from commercially off-the-shelf (COTS) industry-grade products.
- 10.12 The PM&CS equipment shall be designed for ease of access to equipment for maintenance purposes.
- 10.13 The PM&CS equipment shall be designed to allow first line replacement of most components in the event of failure.
- 10.14 The PM&CS equipment shall be designed to operate unattended and with minimal maintenance.
- 10.15 The PM&CS equipment shall be designed to allow most of the servicing requirements to be fulfilled by a preventative maintenance regime.
- 10.16 The PM&CS equipment shall be compliant with the IEC standards for PLC & SCADA equipment, and non-proprietary or open source communications protocols.
- 10.17 The PM&CS equipment shall not incorporate custom or bespoke components, software or systems.
- 10.18 Timestamps shall be made consistent throughout the PM&CS enabling events to be compared in time across all tunnel sub-systems.
- 10.19 The PM&CS time reference source shall be synchronised with the National Physical Laboratory time signal (also known as the MSF Radio Time Signal).

### Communications networks

- 10.20 The SCADA and PLC networks shall be electrically and functionally resilient from each other unless it can be demonstrated that no SCADA system failure modes can adversely affect the PLC communications network operation, or vice versa.
- 10.21 Secure, fault-tolerant and reliable transmission of all data between the operator, plant, equipment rooms, control offices, maintenance depots and all other locations associated with the tunnel shall be provided.
- 10.22 The communications network shall be designed to be resilient against any single cable break.
- 10.22.1 The communications network should be designed to be resilient against any foreseeable hardware failure modes.
- 10.23 The level of resilience and redundancy shall be dictated by the system safety and availability requirements.

*NOTE The determination of required system resilience is particularly important in relation to life safety systems requiring rapid detection of, and response to, incidents.*

- 10.24 All systems shall be provided with effective security measures, including the integration of physical, personnel and cyber security.

*NOTE Recommendations for security measures are published by the Centre for the Protection of National Infrastructure (CPNI) and the National Cyber Security Centre (NCSC).*

### Fault tolerance

- 10.25 The PM&CS design process shall include a failure mode effects and criticality analysis (FMECA) to identify common points of failure with the system.
- 10.26 Where common points of failure in the PM&CS design are identified these shall be eliminated.

- 10.27 All systems and control items shall be designed such that any failure in the instrumentation or control system can cause all associated plant and equipment to go into, or remain in, a safe state.
- 10.28 Determination of what is considered the safe state for a system shall be carried out in consultation with the TDSCG.

### Design life

- 10.29 PM&CS equipment shall be designed for a minimum 20-year service life.
- 10.29.1 The assumption of a design life should not mean that the equipment is no longer fit for purpose at the end of that period.

*NOTE 1 Design life is the minimum period for which the equipment is expected to remain functional, to its design specification, under the anticipated conditions of use and the proposed maintenance regime.*

*NOTE 2 The intention of the minimum 20-year design life requirement is to maximise the service life and plan for obsolescence as far as is reasonably practicable in an environment in which it is impossible to predict what technological, commercial or economic factors might make hardware or software obsolete earlier.*

### Environmental conditions

- 10.30 All equipment enclosures, support steelwork and fixings within the tunnel environment shall be designed to meet category C5 of BS EN ISO 9223 [Ref 11.N] for the design life given.
- 10.31 All plant, equipment, fittings and any other component of the permanent installation within the tunnel and linked areas affected by the tunnel environment shall have an ingress protection rating of at least IP66 as described in BS EN 60529 [Ref 14.N].
- 10.32 All plant, equipment, fittings and any other component of the permanent installation within the tunnel and linked areas shall be tested to withstand the potential water jet velocities expected within the tunnel environment.
- 10.32.1 Water jet velocities within the tunnel may be greater than those specified in BS EN 60529 [Ref 14.N].
- 10.33 Equipment located in areas determined as hazardous by the Dangerous Substances and Explosive Atmospheres Regulations ( UKSI 2002/2776 [Ref 73.N]) report must be ATEX 2014/34/EU [Ref 75.N] approved as required for the application and environment.

### SCADA functional requirements

- 10.34 The SCADA system shall provide the tunnel operator with access to the operational status of all items of tunnel equipment.
- 10.35 The SCADA system shall alert the operator to any circumstances requiring action.
- 10.36 Alarm signals shall be generated by designated events or failures, determined as part of the design process.
- 10.37 Alarm signals shall be graded according to the urgency of the response required by the tunnel emergency plan.
- 10.38 Workstations to receive the output data and signals shall be provided locally at the tunnel and at remote locations.
- NOTE Workstations can be programmed with mimic displays to provide complete or partial control and monitoring facilities.*
- 10.38.1 Workstations may be designed and equipped to cover any number of tunnels from a single location.
- 10.39 Software amendments and updates shall only be carried out following a robust change control process.
- 10.40 Off-line testing shall be carried out before amending the on-line system software or firmware.

*NOTE Control thresholds and setpoints for plant and equipment can be adjusted on line.*

- 10.41 User access control measures shall be provided to prevent unauthorised access to critical areas and processes of the SCADA system.
- 10.42 The following system operating modes shall be provided as part of the SCADA system:
- 1) automatic control;
  - 2) SCADA manual control;
  - 3) incident control; and
  - 4) local manual control.
- 10.43 The PM&CS shall normally operate in automatic control mode.
- 10.44 In the event of a communications failure between SCADA and PLCs, the PLCs shall continue functioning independently, using either the latest remote information, or default values.
- 10.44.1 SCADA manual control mode should allow the PLC system to accept high level commands, via the SCADA system, over-riding the automatic operation for selected plant items.
- 10.44.2 SCADA manual control should be the responsibility of the operator.
- 10.44.3 Upon entering SCADA manual control mode, a suitably worded banner should be present on all SCADA screens.
- 10.44.4 Incident control mode should allow certain operational parameters to be altered by the PM&CS during an incident response e.g. fan MCC instructed to ignore fan vibration or winding temperature alarms, time delays between fan starts reduced from comfortable to minimum.
- 10.45 Upon entering incident control mode, a suitably worded banner shall be present on all SCADA screens.
- 10.46 A local manual control mode shall be made available for specifically identified equipment, based upon push-buttons and lamps, or human/machine interfaces (HMIs), located on, or adjacent to, the equipment control panels.
- NOTE** *A local manual control mode is only normally for maintenance.*
- 10.47 It shall be possible to operate the tunnel safety critical systems in local manual control mode following a total failure of the SCADA system.
- 10.48 Upon entering local manual control mode, a suitably worded indication shall be present on all SCADA workstation screens.
- SCADA hardware requirements**
- 10.49 The SCADA system shall consist of duty / standby SCADA servers together with watchdog link, interface equipment and supporting hardware.
- 10.50 Both SCADA servers shall continuously monitor plant status information from the PLC's, but only the duty server be capable of sending instructions.
- 10.51 Both SCADA servers shall be connected to secure non-volatile backup storage devices.
- 10.52 The SCADA software shall be capable of scheduling automatic transfers of alarm logs to the non-volatile backup storage devices.
- 10.53 The SCADA system shall have at least two operator workstations, located as determined by operational requirements.
- 10.54 Each operator workstation shall be equipped to receive alarm and alert messages and to provide monitoring and control facilities.
- 10.55 The SCADA system shall include one or more workstations, suitably located for use during maintenance activities and/or emergencies.
- 10.56 The SCADA system shall be capable of producing, storing and forwarding logs and reports.

- 10.57 The SCADA system shall store all alarms and events for at least 12 months, archived thereafter for legal/contractual compliance.
- 10.58 Procedures for the handling, storage and downloading of fault, alarm and event data shall be in accordance with local project requirements.
- 10.58.1 Long term storage of fault, alarm and event data on the SCADA servers should be for a period agreed with the OO.
- 10.58.2 A software search engine should be provided to assist in assessment and analysis of fault records.

### **SCADA software requirements**

- 10.59 The SCADA development platform shall be certified by a suitably competent independent third party to demonstrate achievement of the SIL defined in the SIL determination report.
- 10.60 The SCADA application software shall be developed in accordance with BS EN ISO 9241 [All Parts] [Ref 25.N], where appropriate with BS EN 61508-2 [Ref 35.N], and in consultation with the tunnel operation and maintenance organisations.
- 10.61 Programming changes to the SCADA application software shall only be allowed to be made to the standby SCADA server in an off-line mode.
- 10.61.1 Once changes to the SCADA application software have been completed, fully tested and documented, the standby SCADA server may be made the duty server and the new updated programme copied to the now standby SCADA server.
- 10.62 All SCADA run time software licenses shall be novated to the Overseeing Organisation upon handover of the system.
- 10.63 All workstations shall automatically revert to the lowest access level after a predetermined time of inactivity.
- 10.64 It shall not be possible to directly access the PLC application program from any operator or maintainer workstation.

### **SCADA operator interface**

- 10.65 The operator interfaces shall be designed to provide the following functions:
- 1) alarms and indications that the operator needs to see;
  - 2) alarms and indications that the maintainer needs to see;
  - 3) minimisation of information overload of the operator during an incident;
  - 4) presentation of this information to the operator clearly, including appropriate symbols, colours, animations, etc.;
  - 5) commonality of presentation with other systems the operator can use or interface with; and
  - 6) help screens to assist operator decision-making and to provide prompts during an incident.
- 10.65.1 Wherever possible, safety related user interfaces should be developed in consultation with the operational staff who can use the system.
- 10.65.2 The development of safety related user interfaces may be in the form of prototyping and feedback sessions covering the development and use of the HMI ensuring that the design benefits from the experience of the tunnel operational team.

### **SCADA user groups**

- 10.66 Provision shall be made for the following base set of user groups:
- 1) software engineer – access to all SCADA operating functions, updating of software;
  - 2) tunnel manager – addition and amendments of users, backups, defining control parameter availability, etc.;

- 3) tunnel operator – view-only and use for day-to-day operational and emergency response requirements. No changing of control parameters or initiation of control functions;
- 4) tunnel maintainer – changing of a defined subset of control parameters and initiation of defined control functions; and
- 5) observer – view only.

**SCADA alarms, data logging & reports**

10.67 Presentation of alarm signals shall be to BS EN 62682 [Ref 48.N] in consultation, with the tunnel operators and the maintenance organisation.

10.68 During the design process the initiating cause of each alarm type shall be published and a competent group established to classify the category of each alarm, based upon an assessment of the safety and operational impacts.

10.68.1 A scoring matrix, similar to that shown below, should be used to determine each alarm category.

**Table 10.68.1 Example of risk scoring matrix for alarm categories**

	Effect	Category
Safety risk if no action taken	Fatalities	Critical
	Major injuries	High
	Multiple minor injuries	Medium
	Few minor injuries	Low
Operational impact if no action taken	Major delay	Critical
	Moderate delay	High
	Minor delay	Medium
	No delay	Low

10.68.2 The response time for each alarm category should be established.

10.68.3 Other events and records, including as plant switching events, operator login and subsequent actions, and the entry and exit of personnel attending the services building, should be logged.

*NOTE Although these require no action, they provide an historical record useful for fault and post-incident investigation.*

10.69 The SCADA software shall allow alarms received to be acknowledged in any order.

10.69.1 Presentation of alarm data to the operators should be designed to assist identification of the principal event and, suppress subsidiary alarms.

*NOTE It is not unusual for events such as power supply failure or loss of data communications to result in large numbers of consequential failure alarms as individual items of equipment are affected.*

10.70 All fault, alarm and event messages received from the monitoring equipment shall be stored on the SCADA servers for at least three months and then backed up for future reference and analysis, in accordance with the Overseeing Organisation's record retention policy.

10.71 The SCADA system shall be capable of producing site-specific printed reports on demand to aid operation, maintenance, planning, monitoring.

10.71.1 Typical reports may contain the following:

- 1) daily log of events;
- 2) daily fault log;
- 3) daily log of outstanding faults;
- 4) monthly log of events;
- 5) monthly fault log;
- 6) energy usage of selected systems;
- 7) plant running hours;
- 8) air quality versus time;
- 9) traffic counts versus time (if available);
- 10) lighting and ventilation fan stages versus time; and
- 11) weather data (e.g. wind speed, temperature, daylight luminescence).

### PLC functional requirements

10.72 The PLC's shall monitor the normal operating status, alarm conditions and process variables available from all systems and equipment associated with the tunnel including, where installed, the following:

- 1) electrical power supply and distribution system;
- 2) standby or back-up power supply equipment;
- 3) tunnel lighting control system;
- 4) tunnel ventilation system including tunnel environmental sensors;
- 5) tunnel drainage pumping system including any sump environmental sensors, fire suppression systems and sump ventilation systems;
- 6) tunnel fire safety systems; emergency doors and emergency panels;
- 7) traffic monitoring systems including CCTV, incident detection, etc.;
- 8) traffic control systems including approach road and tunnel road signs, signals and barriers;
- 9) tunnel communications systems; and
- 10) building services installations within the local tunnel structures, including fire and intruder alarm systems.

**NOTE** *Because of the high number of potential data points presented by the tunnel lighting system, it is often necessary to limit the level of information required to be transmitted to the PM&CS.*

10.73 Except when under emergency and maintenance conditions, automatic operation of tunnel plant shall be in response to control signals from the various monitors and detectors in the tunnel.

10.74 The PLCs shall facilitate operator control, via the SCADA system, of the following tunnel sub-systems:

- 1) override of the automatic lighting levels in the tunnel;
- 2) override of the tunnel ventilation system;
- 3) override of the drainage pumping plant, sump ventilation and fire suppression systems;
- 4) control of the approach road and tunnel road signs, signals, barriers and any other traffic control equipment; and,
- 5) access control to tunnel service buildings, plant rooms and secure compounds.

10.75 The PLCs shall monitor the energy consumption at the following points in the electrical distribution system:

- 1) all outgoing feeds from the LV switchboard(s); and
- 2) all outgoing feeds from the UPS switchboard(s).

### PLC outstations

- 10.76 PLC outstations shall be strategically located throughout the tunnel installations, linked to each other and to the central processors or monitoring equipment.
- 10.77 Outstations shall receive environmental and performance data from field instrumentation and equipment, allowing the generation of suitable control signals for switching of lighting, ventilation fans, drainage pumps etc., along with alarm and event data.
- 10.77.1 Outstations should generally be located within, or with:
- 1) lighting control panels;
  - 2) motor control centres such as for pumping and ventilation;
  - 3) electrical distribution panels such as main LV switchboards, tunnel distribution points; and
  - 4) communications equipment racks for radio, traffic monitoring.
- 10.77.2 PLC outstations may be either slave PLCs or remote input/output modules (RIOs) to the central PLC's.
- 10.78 The power supplies to outstations shall be taken from the tunnel UPS system enabling the equipment to continue operating uninterrupted during a power outage.

### PLC hardware requirements

- 10.79 PLC equipment including the local I/O and RIO shall be formally certified by a recognised independent authority as achieving the SIL rating defined in the SIL determination report.
- 10.80 Where central PLCs are utilised, they shall be located in separate access-controlled, fire-separated rooms.
- 10.81 The PLC system shall directly handle all inputs and all control outputs.
- NOTE Examples of inputs to a PLC system include equipment status information, alarms and environmental data.*
- 10.82 The PLC system shall carry out all control logic, sequence control functions and data gathering.
- 10.83 The PLC system shall self-check on power-up and continuously monitor its own operation and report faults, via SCADA, to the operator.
- 10.84 All items of plant affected by a fault condition shall be designed to move to a safe condition and any further change inhibited until the fault has been cleared.
- 10.85 Safety PLC outputs shall be positively monitored to prevent unrevealed failures.
- 10.86 Changeover from duty to standby PLC shall be automatic upon detection of a failure.
- 10.87 Changeover from duty to standby PLC shall occur in no more than one second.
- 10.88 There shall be no effect on the output circuit status or false reporting of the input circuit status during, or because of, the changeover from a duty to a standby PLC.
- 10.89 Each PLC shall be provided with an access port for connection to a PC to be used during programming, commissioning, testing, maintenance and program update.

### PLC software requirements

- 10.90 PLC programming software shall be certified by a recognised independent authority to achieve the SIL defined in the SIL determination report.
- 10.91 PLC application software shall be produced using techniques laid out in the manufacturers software programming manuals and in accordance with BS EN 61508-2 [Ref 35.N], to achieve the SIL defined in the SIL determination report.
- 10.92 The PLC application software shall be password protected, providing levels of security that support view only, restricted programming (e.g. changes to defined parameters only), and full access programming.

- 10.93 It shall only be possible to carry out programming, and subsequent alterations to the PLC by secure, and always controlled, cyber secure practices.
- 10.94 Programming changes shall only be allowed to be made to the standby PLC in an off-line mode.
- NOTE* *Once the changes to the PLC application code have been completed, fully tested and documented, the standby PLC can be made the duty PLC and the updated programme copied to the now standby PLC.*
- 10.95 Provision shall be made for all PLC run-time software licenses to be novated to the administrative authority upon handover of the system.

### **Field instrumentation & equipment**

- 10.96 Power supplies for field-mounted transmitters shall be routed via the relevant local control panel and any associated PLC.
- 10.97 All analogue signals entering or leaving a motor control centre (MCC) or control panel shall be fitted with galvanic isolation barriers to prevent ground loops.
- 10.98 Galvanic isolation barriers shall not be loop powered unless it can be demonstrated that isolator failure cannot adversely affect any other functions.
- 10.98.1 Two-wire circuits suitable for 4 to 20 mA operation should be used for analogue devices.
- 10.98.2 Where necessary, optical signal isolators may be provided.
- 10.98.3 Typical parameters for monitoring tunnel plant should include:
- 1) plant status, such as 'running', 'stopped', 'out of service', 'fault';
  - 2) operating state, such as 'high'/'low', 'open'/'closed';
  - 3) hours run;
  - 4) energy consumed;
  - 5) control availability, such as 'local', 'remote', 'off', 'automatic';
  - 6) lighting levels;
  - 7) motor speed; and
  - 8) pollution concentrations.
- 10.98.4 Tunnel ventilation instrumentation may include devices to measure tunnel air velocity, external wind speed and direction, concentrations of pollutants and obscuration.
- NOTE* *Refer to Section 5 on air quality monitoring and ventilation control for details of instrumentation required for the control of the ventilation system.*
- 10.98.5 The tunnel lighting photometers may be connected directly to the relevant lighting control panels or via the PM&CS network, provision shall be made for onward transmission of system status and fault alarms to the PM&CS.
- NOTE* *Refer to the tunnel lighting Section 6 for details of photometers to monitor light conditions at the tunnel portals and threshold zones.*
- 10.98.6 Drainage system sensors should be connected to the relevant sump control panel, although provision can be made for onward transmission of system status and fault alarms to the PM&CS.
- NOTE* *Water level sensors, oxygen depletion and hydrocarbon sensors can typically be utilised for the control of the drainage pumping plant, refer to the tunnel drainage Section 7.*
- 10.99 Where larger motors are used, winding temperatures and vibration shall also be monitored, initiating an alert if pre-defined limits are exceeded whilst operating under normal conditions.
- 10.99.1 Under emergency incident conditions motor alarms should be over-ridden by the PM&CS allowing the motor to run to destruction.

### Uninterruptible power supplies

- 10.100 The power supplies for the PM&CS shall be taken from an uninterruptible power supply (UPS) system, in order to maintain full functionality of the PM&CS during main power outages.
- 10.101 Any field instrumentation required to continue safe operation of the tunnel during power failure conditions shall be connected to the UPS.
- 10.102 The UPS shall form part of the electrical distribution system.
- 10.103 The UPS design shall be co-ordinated with the PM&CS design to ensure that all relevant SIL reliability criteria are met.

### Testing and inspection

- 10.104 The PM&CS shall be designed to enable the following activities to be undertaken with minimal disruption to tunnel operation:
- 1) routine visual inspections of the general condition of the in-tunnel equipment;
  - 2) periodic end-to-end functional testing to check system performance and to maintain the SIL certification.
- 10.105 Prompts for when detailed inspection and maintenance are due shall be provided.
- NOTE To assist in identifying system faults and remedial actions, the SCADA system can be designed or a separate system provided, to store inspection results in a form which can be readily recalled for comparison with current data.*

## 11. Electrical power supply and distribution

### General requirements

#### Fault tolerance

- 11.1 The tunnel electrical distribution systems shall be designed such that no single equipment, cable or power supply failure can result in:
- 1) an unsafe situation;
  - 2) the failure to maintain MOR;
  - 3) the inability to maintain normal traffic flow; or
  - 4) the inability to promptly close the tunnel to traffic if required.
- 11.2 The tunnel electrical distribution system design process shall include a failure mode, effects and criticality analysis (FMECA) to identify common points of failure within the tunnel electrical distribution system.
- 11.3 Where common points of failure are identified by the FMECA these shall influence the design to ensure they are removed.
- 11.4 The risk and impact of unplanned loss of supply, to any equipment that is required to maintain normal traffic flow, shall be subject to ALARP principles.
- 11.5 The tunnel electrical systems shall be arranged such that, in the event of failure of one incoming supply, all essential electrical loads can be automatically transferred to the remaining supply without creating a hazard to road users, staff or emergency services within the tunnel or on the approach ramps.
- 11.6 Incoming supplies, and key items of equipment such as transformers and main distribution cables, shall be provided in sufficient number and size to ensure that if one is out of service, either due to fault or maintenance, tunnel operation can be maintained for a period in excess of the time required to return failed unit to service.

#### Design life

- 11.7 Electrical equipment, cabling and support systems shall be designed with a minimum 25-year design life.
- 11.7.1 The assumption of a design life should not mean that the equipment can no longer be fit for purpose at the end of that period.
- NOTE The design life is the minimum period for which the equipment is expected to remain functional, to its design specification, under the anticipated conditions of use and the proposed maintenance regime.*
- 11.8 Minimum standards for the design and installation of the tunnel electrical distribution system shall be those given in TS 101 [Ref 80.N].

#### Environmental conditions

- 11.9 All equipment enclosures, support steelwork, cable containment and fixings within the tunnel environment shall be designed to a minimum of C5, in accordance with BS EN ISO 9223 [Ref 11.N], for the design life given.
- 11.10 All plant, equipment, fittings and any other component of the permanent installation within the tunnel and linked areas affected by the tunnel environment shall have an ingress protection rating of at least IP66 as described in BS EN 60529 [Ref 14.N].
- 11.11 All plant, equipment, fittings and any other component of the permanent installation within the tunnel and linked areas affected by the tunnel environment shall be tested to withstand the potential water jet velocities expected within the tunnel environment.
- 11.11.1 Water jet velocities within the tunnel may be greater than those specified in BS EN 60529 [Ref 14.N].

- 11.12 All equipment enclosures, support steelwork, cable containment and fixings external to the tunnel environment shall be designed to a minimum of C3, in accordance with BS EN ISO 9223 [Ref 11.N], for the design life given.
- 11.13 All equipment enclosures, support steelwork, cable containment and fixings external to the tunnel or in plant-rooms shall be designed with an ingress protection rating of at least IP66 as described in BS EN 60529 [Ref 14.N].
- 11.14 Equipment located in areas determined by the 'Dangerous substances and explosive atmospheres regulations' ( UKSI 2002/2776 [Ref 73.N]) as hazardous must be ATEX 2014/34/EU [Ref 75.N] approved as required for the application and environment.

### **Maintainability**

- 11.15 The location of all plant and equipment, and the associated electrical distribution, shall be designed such that inspection, maintenance, troubleshooting, repairs or replacement can be carried out easily and safely, with a minimum of disruption to the normal operation of the tunnel.
- 11.16 All equipment separation and access space shall be in accordance with manufacturers recommendations.
- 11.17 The need for staff to work at height or in confined spaces shall be minimised.
- 11.18 The use of extra low voltage equipment shall be maximised and use of low and high voltage equipment minimised.
- 11.19 A safe means of permanent access to all maintainable equipment shall be incorporated into the design.
- 11.20 Plant and equipment shall be designed to minimise access and maintenance requirements that require tunnel closures.
- 11.21 Standardised designs, sizes and ratings of plant and equipment shall be used throughout, with similar components interchangeable, to simplify and reduce the requirements for stocking spares.

### **Incoming power supply arrangement**

#### **Demand assessment**

- 11.22 The electricity demand for each system (lighting, ventilation, pumping, etc.), shall be assessed under normal, abnormal and emergency operating conditions to determine:
- 1) the maximum demand, in kVA;
  - 2) any phase imbalance; and
  - 3) the likely power factor.
- 11.23 Any load shedding to reduce the peak electrical loads shall be risk assessed to demonstrate that the safety of the tunnel and tunnel users is not compromised and MOR is maintained.

#### **Distribution network operator (DNO) consultation**

- 11.24 The DNO(s) shall be consulted early in the design stage to confirm their ability to provide electrical supplies which are fit for purpose in terms of capacity and voltage, and fit for use in terms of availability, reliability and resilience.
- 11.24.1 In terms of resilience, the first upstream common point of failure for dual supplies should be established as part of the process of assessing resilience.
- 11.25 Duplicate incoming supplies, one on each side of the tunnel, shall be provided with each independently capable of supporting the tunnel maximum demand.
- 11.26 Supply sources shall be independent and the cabling associated with each, separately routed.
- 11.27 Historic supply failure statistics shall be requested from the DNO to complete the operational risk assessment for the tunnel.

- a) the DNO data received can only be approximate or typical data for representative parts of their networks;
- b) measures should be taken to verify that data used is truly appropriate;
- c) experience has shown that sections of networks containing 11 kV and 33 kV overhead lines can be subject to a higher than average fault rate due to storm damage; and
- d) DNO records of system faults can be based on prolonged outages and not short term interruptions or transients due to lightning strikes or switching operations, which are regarded as normal events.

## High voltage (HV) system

### HV switchgear

- 11.28 Each incoming HV feeder shall terminate in a separate 2-hour fire compartment.
- 11.29 Each incoming HV feeder shall be separately metered.
- 11.30 The consumer's HV switchgear shall be installed in separate fire-rated enclosure or, if ring main units are utilised, close coupled to the incoming supply transformers.
- a) HV switchgear should consist of metal-enclosed, ring-main units, suitable for 12-kV continuous and 75-kV impulse level;
  - b) transformer protection should utilise vacuum or SF6 circuit breakers with a current rating to match the demand and a minimum fault level of at least 250 MVA.
- 11.31 Source changeover switching at HV shall only be used where appropriately qualified personnel will be available to carry out HV switching operations.
- 11.32 Where HV standby generation equipment is used, the associated HV switchgear shall be installed in a separate 2-hour fire compartment.
- 11.33 Circuit breakers shall be of the spring-operated type with shunt trip and manual reset.
- 11.34 Where a consumer's HV switchboard is required, as opposed to close-coupled ring-main units, each HV switchboard shall have separate batteries for tripping and closing / spring winding duties.
- 11.35 Sufficient controls and indicators shall be provided to allow safe operation of the switchgear by manual means.
- 11.36 Status and alarm monitoring of the switchgear and incoming supplies shall be carried out both locally, by means of indication lamps on the switchgear, and remotely via the SCADA system.

**NOTE** *Remote switching for interconnectors to be supported by robust switching programme, as part of the safe system of works.*

### HV cabling

- 11.37 Where HV cable interconnectors are to be installed between HV switchgear at opposite ends of the tunnel, they shall be installed within the road deck in separate bores.

### Transformers

- 11.38 Each transformer shall be located within a fire-separated enclosure designed such that any failure in one transformer cannot adversely affect another unit.
- 11.39 Transformers shall be of the 11000/400V Dyn11 type, with sufficient kVA rating to enable one transformer to carry the whole of the maximum demand that may be connected without causing the transformer to overheat.
- 11.39.1 Depending on local conditions, other primary voltages may also be required.
- 11.39.2 The design may incorporate vector groups other than Dyn11 where large inductive loads are connected.

**HV protection systems**

- 11.40 HV protection relays shall be of the static type.
- 11.41 Time delays on protection relays shall be designed to ride through transient supply disturbances to avoid unnecessary tripping of the tunnel incoming circuit breakers.
- 11.42 Restricted earth fault (REF) protection shall be provided for the protection of the secondary transformer windings.
- 11.43 HV and LV transformer winding temperature pre-alarm and alarm signals shall be provided to trip the HV circuit breaker and SCADA indication.

**Fireman's switch**

- 11.44 A fireman's switch shall be provided in an agreed location to allow the local fire and rescue services to isolate all electrical supplies to tunnel equipment, before they commence fire fighting.
- 11.45 Those tunnel systems designed with the specific purpose of supporting fire fighting operations, and to be resistant to fire and water jets, shall be discussed with the local fire and rescue service to agree a mutually acceptable firefighting solution.

**Low voltage (LV) system****LV switchboards**

- 11.46 LV switchboards shall be designed with two bus sections, designated A and B, separated by a bus coupler and fed from separate transformers.
- 11.46.1 Loads connected to the two halves of the switchboard should be divided more or less equally between the two sections, such that if one supply fails only half of the connected equipment would lose power until corrective action is taken to transfer all loads onto the healthy supply.
- 11.47 The design shall determine if a third bus section is required for the connection of standby generation plant and/or centralised ups.
- 11.48 LV switchrooms shall be designed with at least 1.0 m of unobstructed space at the ends of the switchboard, and at least 1.25 m of unobstructed space to the front and rear of the switchboard with the largest door open.
- 11.49 LV switchboards shall:
- 1) provide a minimum form of separation of 4a type 2 in accordance with BS EN 61439-2 [Ref 45.N];
  - 2) be rated for a minimum of 50kA fault levels for 1 second;
  - 3) be bottom entry;
  - 4) be a maximum of 2.2 m high;
  - 5) have controls and indications between 0.45 m and 2.0 m above finished floor level;
  - 6) have a minimum of 25% spare outgoing ways, at least one of each size used; and
  - 7) have a neutral earth link for connection to the transformer star point.

**Protection systems**

- 11.50 An interlock shall be provided such that if an HV transformer protection circuit breaker trips, the associated LV circuit breaker, on the LV side of the transformer, also trips.
- 11.51 Discrimination shall be maintained throughout each circuit and sub-circuit, to prevent unnecessary tripping of higher level circuits.
- 11.52 All protection system calculations shall be verified against the external conditions presented by all relevant electrical sources such as main incoming supplies, standby generation equipment, UPS equipment, and the like.

- 11.53 The requirements of BS EN 62305-4 [Ref 54.N], for the protection of electrical and electronic circuits against lightning, shall be incorporated into the design.

### **Power factor**

- 11.54 Power factor correction equipment shall be installed as necessary to achieve a minimum overall power factor of 0.95 at the point of connection of the incoming supplies.

*NOTE 1 Maintaining a high power factor is necessary to minimise tariff penalties from the supply authority and to reduce electrical losses.*

*NOTE 2 In smaller tunnels, it is often more cost effective to pay the tariff penalty.*

### **Harmonics**

- 11.55 The effects of harmonic currents and distortions shall be catered for in the design of the sub-main distribution system.
- 11.55.1 Harmonics should be minimised such that they do not impact the functionality, speed of operation or failure rate of connected equipment.
- 11.56 Where filtering required it shall provide compliance with the latest Energy Networks Association (ENA) G5/4-1 [Ref 51.N] standard.

### **3-phase supply**

- 11.57 The minimum requirement regarding balancing of the 3-phase supply shall be that in all likely foreseeable operational, incident and maintenance scenarios, the manufacturer's warranty of any connected 3-phase equipment is not invalidated by voltage or current imbalance(s), or, the potential difference between earth and neutral, with further efforts to balance the supply being limited to minimising whole life costs in terms of design costs, neutral cable heat losses, cable sizing and load balancing costs.

### **Energy monitoring**

- 11.58 The LV distribution shall incorporate energy consumption meters, connected to the PM&CS system, for at least the following circuits:
- 1) all outgoing supplies from the LV switchboard; and
  - 2) all outgoing supplies from the UPS switchboard.
- 11.58.1 Equipment, now available for real-time monitoring of energy use for energy cost savings, should be specified.

### **Distribution panels**

- 11.59 The optimum spacing of distribution panels (DP) through the tunnel shall be based upon the following:
- 1) the location of final sub-circuits serving lighting, signs and signals, traffic monitoring equipment, instrumentation, control and communications equipment, and similar systems,
  - 2) how the tunnel services will be affected if a fire occurs adjacent to a panel,
  - 3) the size of the required sub main cabling; and
  - 4) access for fault finding, inspection and repair activities whilst minimising disruption to tunnel operation.
- 11.60 The DPs shall:
- 1) incorporate separate sections for A, B and UPS supplies;
  - 2) use similar construction and materials to other tunnel panels providing a consistency of appearance throughout the tunnel;

- 3) limit the internal temperature, when operating under normal conditions, to the rated limits of the installed equipment;
- 4) provide sufficient space for all equipment and connections, terminations and space for bending radii of for all incoming and outgoing cables and tails; and
- 5) incorporate bottom cable entry:
  - a) where possible DPs should be installed in areas of low fire or impact risk for example within cross passages;
  - b) DPs may incorporate other electrical equipment such as connections for CCTV, communications, traffic loop detectors, control outstations and such like;
  - c) suitable maintenance socket outlets (110VAC) and special socket outlets for the use of the fire brigade may be required.

**NOTE** *It can be convenient to combine DPs in the tunnel with emergency panels (EPs). Where this is done the combined panels are designated Emergency/Distribution Panels (EDPs).*

### **Lighting circuits**

- 11.61 Each lighting distribution panel section shall be independently fed by a cable dedicated to that section.
- 11.62 Lighting circuits shall be arranged such that adjacent luminaires are connected to different circuits, different phases, and are supplied from different incoming sources.

**NOTE** *By interleaving lighting circuits, failure of one supply will then only result in the loss of a maximum of 50% of the lighting in the affected area and reduce the need to fall back on emergency or standby lighting.*

- 11.63 All emergency lighting circuits, including emergency, evacuation and exit lighting, shall be wired using cabling in accordance with BS 8519 [Ref 64.N].
- 11.64 Where a prefabricated wiring system is used the plugs and sockets shall have the same fire rating as the cable to which they are attached.
- 11.65 Where a prefabricated wiring system is used the plugs and sockets shall have an ingress protection rating of IP66 in accordance with BS EN 60529 [Ref 14.N].

### **Ventilation fan circuits**

- 11.66 The electrical distribution, switchgear and control facilities for the tunnel ventilation system shall be segregated from electrical circuits serving other systems.
- 11.66.1 Adjacent fans may be on separate circuits for resilience.
- 11.67 Fan starter equipment, including source changeover equipment, shall be installed in areas of low fire or impact risk.
- 11.68 Local control/starter panels located in the tunnel shall be manufactured using the same environmental and aesthetic features as the DPs.
- 11.69 All ventilation fan circuits shall be wired using category 3 cabling in accordance with BS 8519 [Ref 64.N].

### **Earthing & bonding**

- 11.70 Earthing systems to provide equipotential bonding, frame earthing, neutral point earthing, computer system "clean" earths and general protection shall be provided in accordance with the requirements of BS 7430 [Ref 8.N] and BS 7671 2018 [Ref 55.N].
- 11.71 Earthing and bonding connections between the main earth bar(s) in the tunnel service building(s) and tunnel EDPs shall utilise a separate circuit protective conductor (CPC) and not rely solely on the armouring of the sub-main cables.

### Standby power

- 11.72 A structured assessment shall be carried out early in the design process to determine the likelihood of electrical supply failure and the consequential effects of such failure.
- 11.73 The tolerable risk of mains failure and the level, hours of operation and duration of service to be maintained in the event of mains failure shall be determined in consultation with the TDSCG and Overseeing Organisation.
- 11.74 The objective of maintaining power supply in the event of mains failure shall be selected from the following scenarios, assessed on the basis of impact of tunnel closure to the major transport networks and economic impact at a local and national level:
- 1) sufficient power and energy to close and evacuate the tunnel;
  - 2) sufficient power and energy to close and evacuate the tunnel and operate the emergency lighting to allow safe access by operatives and emergency services;
  - 3) sufficient power and energy to operate the tunnel above MOR or, below MOR but with mitigations in place, for a short period of time, to either:
    - a) set up the diversion route for a tunnel closure;
    - b) operate the tunnel for a period equal to the DNO reinstatement service level agreement time;
  - 4) sufficient power and energy to operate the tunnel above MOR or, below MOR but with mitigations in place, for a longer period of time, to either:
    - a) connect a standalone transportable generator;
    - b) operate the tunnel for the period taken to rectify a major or catastrophic incident on the transmission or distribution networks;
    - c) operate the tunnel for the period taken to rectify a major or catastrophic failure to the tunnel HV switchgear or HV/LV transformer.
- 11.75 The method(s) of reducing the risk of mains failure and maintaining power supplies in the event of mains failure, shall be selected from the following and assessed upon fitness for purpose, fitness for use and whole life costs:
- 1) reinforcement of electricity transmission network or change of connection points with that network;
  - 2) reinforcement of electricity distribution network or change of connection points with that network;
  - 3) battery storage (including UPS);
  - 4) energy storage (e.g. flywheel);
  - 5) standby generator (including fuel cell).
- 11.75.1 Method(s) of reducing the risk of mains failure and maintaining power supplies in the event of mains failure, may be used in combination to achieve peak lopping.
- 11.76 Load calculations for all forms of standby power generating plant shall include provision for starting currents, harmonics, fault clearance and UPS battery recharging.
- 11.77 A limited amount of UPS provision shall be provided to cover the short period required for non-UPS power (e.g. generator) to come on-line.

### Uninterruptible Power Supply (UPS)

- 11.78 UPS and battery sets shall be provided to power, in the event of a main electrical supply failure, to maintain essential life safety systems.
- 11.79 The UPS and battery sets shall also support the tunnel lighting systems.
- 11.80 The reliability of all UPS supplying power to life safety systems shall be included within the SIL assessment, in accordance with BS EN 61508-2 [Ref 35.N], for those systems.

- NOTE 1** *It is likely that the need for supply power to life safety systems in accordance with BS EN 61508 [All Parts] [Ref 36.N] will lead to a need for UPS sets to be installed in an N+1 configuration.*
- NOTE 2** *It is important to ensure that the UPS provides all supplied equipment with electrical power of sufficient quality and protects against malfunctions from voltage transients and other mains-borne disturbances.*
- 11.81** UPS failures shall be logged as an alarm condition and immediately reported on the SCADA system.
- 11.82** When any UPS is operating in an islanded mode (that is with all incoming power supplies isolated), a means of maintaining the earth/ neutral reference to all outgoing circuits shall be provided.
- 11.83** Each UPS system design shall comply with the following factors:
- 1) the type of load to be fed and the characteristics (for example power factor and current inrush) of the load;
  - 2) the capability of the UPS to supply sufficient power to clear faults;
  - 3) acceptable limits of harmonics fed back into the power supply network, particularly where a standby generator is installed;
  - 4) compatibility with standby generator plant, where provided;
  - 5) the minimum period of time the UPS is required to operate under full load after mains supply failure (normally two hours);
  - 6) operational and physical compatibility with other electrical equipment;
  - 7) compliance with BS 5266 [All Parts] [Ref 23.N] for recharging times after discharge;
  - 8) control equipment to be provided;
  - 9) the requirement for an external bypass to allow the unit to be replaced whilst maintaining a supply to the essential loads;
  - 10) the ability to remotely control the UPS from the PM&CS;
  - 11) the potential requirement for a standby UPS; and
  - 12) to have a spare capacity of 25% for future expansion.
- 11.84** Sufficient UPS power shall be provided to allow all life safety services to be maintained until either:
- 1) restoration of a main supply; or
  - 2) standby generating equipment is brought into operation; or,
  - 3) a predetermined tunnel evacuation and diversion of traffic is achieved, as decided by the OO.
- 11.85** The essential loads shall be permanently connected to the UPS equipment such that in the event of a mains failure their supply is maintained.
- NOTE** *Components of the essential load are likely to include the following:*
- 1) *emergency lighting;*
  - 2) *standby lighting;*
  - 3) *evacuation lighting;*
  - 4) *emergency exit signage;*
  - 5) *plant monitoring and control systems;*
  - 6) *communications systems including public address / voice alarm, radio and telephone systems;*
  - 7) *traffic monitoring and control systems, including CCTV, incident detection, signs and signals;*
  - 8) *emergency power tool sockets (if required by the fire and rescue service); and*
  - 9) *other relevant components unique to the tunnel under consideration.*

### **Standby generating plant**

- 11.86** Automatic start standby generating equipment shall be used where drainage pumps, ventilation plant or full threshold and transition zone lighting will need to be operated under total mains failure conditions.

*NOTE* Such loads will generally be beyond the capacity of a UPS.

11.87 Standby generation equipment shall supply power at low voltage unless rendered untenable by the supported loads.

*NOTE* The supply voltage of standby generation equipment, and the point of connection within the system, will be dependent upon the normal electricity supply arrangement.

11.88 Where standby supplies are required at both ends of the tunnel a cost analysis shall be carried out to determine the optimum arrangement.

*NOTE* Options can be:

- 1) LV standby generation at one end with an LV interconnector;
- 2) LV standby generation at both ends;
- 3) LV standby generation coupled to the HV network via a step-up transformer enabling utilisation of an HV interconnector; and
- 4) HV standby generation.

11.89 Separate accommodation, within 4-hours fire-protected enclosures, shall be provided for the standby generating equipment, fuel tanks and associated equipment.

11.89.1 The provision of a generator should be assessed, particularly considering competing demands that can be made for use of such plant and the likely time required to bring the mobile generator to the tunnel site and connect it.

11.89.2 As an alternative to permanently installed standby generating plant, suitable connection points may be provided for the use of mobile generators.

11.90 Bulk fuel storage in tanks with security, shall be provided to store sufficient fuel for seven days running at full load.

11.91 A dump tank shall be provided external to the diesel-set room to automatically take the contents of the day service fuel tank should a fire occur.

11.92 The dump tank shall be provided with pumps to empty it back into the bulk storage tank.

11.93 The standby generating plant fuel level status shall be monitored by the PM&CS system, for usage and to inform on leaks and theft, and alarms passed to the tunnel operator.

### **Cabling**

11.94 Cables from the 'A', 'B' and UPS supplies shall be routed separately to minimise the risk of loss of any two circuits simultaneously.

11.95 Strict segregation between sub-main cables connected to 'A', 'B' and UPS supplies shall be maintained in all locations including:

- 1) ducts;
- 2) equipment entry points; and
- 3) cable trays.

### **Services in the tunnel**

11.96 Cables feeding life-safety services in the tunnel shall be in accordance with category 3 of BS 8519 [Ref 64.N].

11.97 Cable support systems shall be designed to retain their integrity under fire conditions in accordance with BS 8519 [Ref 64.N].

11.98 Sub-main cables connected to 'A', 'B' and UPS supplies shall pass through cable draw-pits within the tunnel, to enable cable segregation to be maintained.

11.98.1 Where cables are to be run in verge ducts on either side of the carriageway, lighting sub-mains should be run in the near-side verge.

11.99 Where jet fan ventilation is employed, cabling shall be located in the off-side verge.

### **Services below ground (outside the tunnel)**

11.100 Where cables are installed underground, it shall be arranged for only one power cable to be installed in each duct.

11.101 At least 25% spare ducts shall be provided to allow for future requirements.

11.102 All ducts shall be sealed to deny vermin habitat but allowing unused ducts to be readily brought into service.

### **Services in switchrooms and services buildings**

11.103 The design of switchrooms and service buildings shall allow sufficient under floor space for other utility services, risk assessed and under specific conditions.

11.104 Cable trenches or raised floor systems shall be provided in all LV and HV switchrooms and around transformers, and of sufficient depth to allow minimum bending radii to be easily achieved.

11.105 Cable voids must conform to building regulations UKSI 2010/2214 [Ref 71.N] and local authority requirements.

11.106 Fire partitioning and barriers to aid system segregation shall be incorporated into cable voids.

11.107 Cables shall not be run beneath the floor in battery rooms.

### **Cable design requirements**

11.108 All cables shall have copper cores inside the tunnel.

11.108.1 Cables outside the tunnel may have aluminium cores.

11.109 Cable cores over 2.5 mm<sup>2</sup> shall be stranded (except for MICC cables) where used on any part of the lighting, power distribution, final circuit and control systems.

11.110 Cable entry glanding materials shall be suitable for a road tunnel environment and the material into which the gland is to be fitted.

11.111 All exposed HV and LV cables shall be steel-wire armoured or provided with an equivalent means of mechanical protection.

### **Cable and termination identification**

11.112 A system of unique identifier codes for cables, and cable cores in terminations, shall be established if not already in place and recorded in the O&M manual.

11.113 The cable code shall be fixed, over the cables external sheath, using standard cable markers, normally at the following locations:

- 1) at each cable termination;
- 2) within each draw pit;
- 3) either side of any barrier; and
- 4) at agreed intervals along exposed lengths of cable.

11.114 Cable cores and terminations shall be identified, with a suitable code of alphabetic and numerical symbols, by means of pre-engraved indented circular markers closely fitted to the core insulation of each constituent core.

11.115 Cores not utilised shall be identified as 'spare'.

11.116 Individual terminals shall be provided for all spare cores.

## 12. Tunnel service buildings and plant rooms

### General

- 12.1 Plant rooms shall be sized, not only to accommodate the plant and associated systems to be installed initially at the tunnel, but also to provide for any reasonably foreseeable future requirements.
- 12.1.1 The provision of underground plant rooms should be avoided.
- NOTE 1* *Underground plant rooms can be necessary in longer tunnels, typically in excess of 1 km in length, where routes for electrical cables or pipework would be too long to be economically served from either end of the tunnel, or in locations where space at ground level is at a premium. Pump rooms associated with in-tunnel pumping stations can also come into this category.*
- NOTE 2* *The siting and general requirements of the service buildings are discussed in Section 2.*
- NOTE 3* *Tunnel service buildings and plant rooms will typically house the main electricity substation, mechanical, electrical and communications equipment and a local control facility for a tunnel.*
- 12.1.2 Additional structures may be required for substations and plant rooms at other locations adjacent to the tunnel.
- 12.2 The building layout shall facilitate management of operations and maintenance and reflect the system of tunnel management to be adopted, for example for manned or unmanned tunnels.
- 12.2.1 When designing underground plant rooms, the following aspects of design should be included:
- 1) the means of providing safe access and egress for inspection and maintenance activities, including unplanned visits for fault investigations;
  - 2) the need for an in-tunnel lay-by for parking maintenance vehicles (and protection of the lay-by from inappropriate use at other times);
  - 3) the provision of fresh air for ventilation and cooling purposes;
  - 4) the protection of any equipment associated with life safety systems from a fire in the tunnel;
  - 5) the risk of flooding at low points due to extreme rainfall, fire main failure or via duct runs;
  - 6) risks to the public arising from a fire in the plant room; and
  - 7) the possible need to designate the plant room as a confined space.
- 12.3 Where the service buildings are intended to be unmanned, they shall include provisions for occasional use as a temporary control facility during maintenance and emergency operations.
- 12.3.1 A small office may be provided for use by the maintenance supervisor during maintenance closures, together with WC and hand-washing facilities for all staff.
- 12.3.2 If operational requirements justify other rooms they may include:
- 1) a separate meeting room that can potentially be used as a forward command point for use by the emergency services attending a major incident;
  - 2) a store room for essential spares; and
  - 3) a workshop for use by maintenance staff carrying out repairs.
- 12.4 Outside the main building a vehicle hard-standing shall be provided with access for fire-fighting vehicles, equipment and personnel.
- 12.4.1 In addition to the facilities required for the tunnel equipment and systems, maintenance workshops, stores, messing and toilet facilities may be required for operational and maintenance staff.
- 12.4.2 A helicopter landing pad may be needed in remote or difficult to access locations.
- 12.5 Accessible floor voids shall be provided for cabling beneath all communications rooms, control rooms, LV switchrooms and HV switchrooms.

- 12.5.1 Floor loadings of all electrical equipment, including access and replacement routes, should be calculated and included within the civil engineering design.
- 12.6 Access to the service buildings and surrounding compounds shall be controlled and managed to prevent unauthorised entry.
- 12.7 Security shall be provided to protect all materials and equipment.

### **High-voltage (HV) equipment rooms**

- 12.8 High-voltage (HV) switchgear, metering equipment and transformers shall be housed in a secure room or enclosure that is fire-separated from all other equipment and provided with independent access.
- 12.9 Dimensions, layout, cable ducts and trenches, earthing provisions and similar provisions for HV equipment shall be agreed with the DNO.
- 12.10 BS 4142 [Ref 49.N] HV equipment associated with different incoming supplies, for example 'A' and 'B' supplies, shall be segregated by walls or partitions designed to resist the spread of fire.
- 12.11 Individual transformers shall be segregated by blast-resistant walls or partitions designed to resist the spread of fire.
- 12.12 Where oil-filled transformers are to be installed, bunding arrangements shall be provided to contain any leakage or spillage of oil.
- 12.13 Outdoor bunds shall be provided with a means of collecting and removing rainwater that falls within it.

### **Standby generators and fuel storage tanks**

- 12.14 Standby generators shall be installed in a dedicated room within a service building, or externally as a package unit in a containerised enclosure.
- 12.15 Space shall be provided for the removal and replacement of the generator set.
- 12.15.1 Space provided should include for craneage of generators or other equipment.
- 12.16 Provision shall be made in accordance with BS 5228 [All Parts] [Ref 7.N] for the control of noise from the generator, both externally as a potential nuisance to nearby properties, and internally if a manned control room is to be provided in the same building.
- 12.17 The impact of generator noise shall be assessed in accordance with BS 4142 [Ref 49.N].
- 12.18 All required fuel storage tanks shall be bunded in accordance with the relevant national regulations.
- 12.18.1 Provisions should be provided to avoid spilt or leaking fuel from entering cable ducts.

### **Low-voltage (LV) equipment rooms**

- 12.19 LV switchrooms shall be provided to accommodate the main LV switchboards, motor control centre(s) for ventilation and other mechanical plant, tunnel lighting control equipment and UPS rectifier/inverter modules, together with ancillary equipment such as required outstations associated with the plant monitoring and control system.
- 12.19.1 LV switchrooms should be located and arranged to minimise the lengths of run for power cables, and therefore the physical sizes of those cables.
- 12.20 Ventilation and/or cooling shall be provided so that heat-emitting equipment such as UPS sets does not cause excessive temperature rise in the switchroom under worst-case operating conditions.

### **UPS battery room**

- 12.21 UPS batteries shall be located in a dedicated room with a solid floor with an acid-resistant finish and continuous ventilation.

**NOTE** *UPS batteries are located in dedicated rooms due to the risks of evolution of hydrogen gas and/or of spillage of electrolyte from some types of batteries.*

12.22 The floor of the dedicated battery room shall have drainage outlets to allow for electrolyte and cleaning water removal.

12.22.1 The drainage outlets of the dedicated battery room floor may be connected to the sink drain within the room.

12.23 A DSEAR risk assessment shall be carried out to determine the requirement for battery rooms to be classified as hazardous areas in accordance with BS EN 60079-10-1 [Ref 28.N].

12.24 Battery rooms shall be temperature controlled so that the batteries are always operating within their optimum ambient temperature range to maintain performance and maximise service life.

**NOTE** *Battery manufacturers recommend optimum ambient temperature ranges.*

### **Control and communications equipment rooms**

12.25 Communications equipment and cables must be segregated from HV and LV switch-gear, cabling and generator plant to EMC Directive 2014/30/EU [Ref 20.N] to prevent the risk of radiated interference.

12.25.1 In order to replace equipment before decommissioning old equipment space should be allowed for additional rack enclosures to be installed.

12.26 Control and communications equipment rooms shall be temperature controlled so that the optimum ambient temperature is maintained within the range necessary for the functioning of the installed equipment.

### **Local control room**

12.27 A dedicated local control room shall be provided if a manned control facility is required over and above the occasional use required for engineering and maintenance activities.

12.28 The layout and level of equipping of the local control room shall be determined where possible in consultation with the tunnel operators and the maintenance staff who will use it, to establish all the requirements to be provided.

12.28.1 Where a local control room is included, a mess room should be provided for the anticipated needs of the control room staff to comply with Workplace Health, Safety and Welfare Regulations UKSI 1992/3004 [Ref 79.N].

**NOTE 1** *Usage of the local control room can vary from emergency use only, as a backup to a remote control facility, through to full continuous operation.*

**NOTE 2** *The extent of equipment to be accommodated within the local control room, for access and secure operation by authorised, competent persons, can vary according to the degree of integration of systems with the SCADA system, but typically includes the following:*

- 1) *dual SCADA system HMIs with monitor screens;*
- 2) *printer;*
- 3) *traffic surveillance CCTV monitor screens and controls;*
- 4) *security and incident detection system monitor screen(s) if separate from the above;*
- 5) *telephones for normal and emergency use; and*
- 6) *PA/VA system microphone and controls.*

12.28.2 The local control room having a window with a view of the approach road to the tunnel, where feasible, may be of benefit in allowing staff to observe traffic and weather conditions.

12.29 The design of the lighting in the local control room shall be co-ordinated with the layout of desks and equipment so that work surfaces are lit with no obscuring reflections or glare on monitor screens, keyboards, and the like.

- 12.30 Mobile phone reception of the mobile network operators in this room shall be equal to that experienced outside of the building.

### Building services

- 12.31 Heating shall be provided in all equipment rooms for frost protection and to prevent condensation.
- 12.32 Heating shall be provided for the correct functioning of equipment and to comfort levels in the office, mess room and local control room (where relevant).
- 12.33 Lighting shall be provided in accordance with the recommendations within BS EN 12464-1 [Ref 43.N].
- 12.34 Emergency lighting shall be provided in accordance with the requirements of BS EN 50172, BS 5266-8 [Ref 21.N] and BS EN 1838 [Ref 44.N].
- 12.34.1 Standby lighting, to permit continued use of selected areas if normal power fails, should be provided if capacity is available from the UPS and or a standby generation source.
- 12.35 Power socket-outlets shall be provided in all equipment rooms, the office, mess room and local control room (where provided) and at intervals along access corridors for cleaning and maintenance purpose and the connection of portable equipment.

### Lightning protection

- 12.36 An assessment of the need for lightning protection for the service buildings and the equipment within them shall be carried out as described in BS EN 62305 [All parts] [Ref 53.N].
- 12.37 Lightning protection shall be installed, where required, in accordance with BS EN 62305 [All parts] [Ref 53.N].

### Intruder alarm system

- 12.38 The service buildings shall be provided with an intruder alarm system comprising alarm contacts on all external doors and windows.
- 12.38.1 Where necessary, internal areas, for example the roof space, should be additionally protected by passive infra-red (PIR) or microwave movement detectors.
- 12.38.2 Where roof voids are present, the risk of false alarms should be assessed.

*NOTE False alarms can be caused if birds and other creatures can gain access to roof voids.*

- 12.39 Operation of a mortice-type door key-switch at the services buildings shall initiate a "staff on duty" signal for logging by the SCADA system.
- 12.40 Forced entry through any of the outside doors or windows shall initiate an alarm condition to activate an external alarm bell and transmit an alarm signal to the operator and/or the police via the SCADA system.

*NOTE Guidance on alarms can be found in Section 10.*

- 12.41 An external self-contained alarm sounder shall be provided.
- 12.42 External self-contained alarm shall have its own battery unit and internal relays with the facility to be instantly activated in the event of the wires being severed or the bell removed.

### Fire alarm and extinguishing systems

- 12.43 A fire alarm and automatic fire-extinguishing system shall be provided in the service buildings.

*NOTE Guidance on fire alarms and automatic extinguishing systems can be found in Section 8.*

### External areas

- 12.44 Provision shall be made close to the tunnel service buildings for the following:

- 1) parking and turning spaces for vehicles used by maintenance and operational staff; and
- 2) hard standing for lorries and/or cranes used for delivering and removing large items of plant, fuel deliveries for any standby generation plant or for siting a temporary generator.

12.44.1 Where necessary, parking space for emergency services vehicles attending an incident should be provided.

12.44.2 The parking space for emergency vehicles should be provided with lighting for access and security purposes and to support night-time maintenance activities.

12.44.3 The parking space for emergency vehicles should be surrounded by a security fence with an access-controlled gate.

*NOTE It can be desirable to provide CCTV coverage of the parking space for emergency vehicles as an extension to the tunnel traffic surveillance CCTV system.*

12.44.4 Where service buildings and plant rooms are located away from a tunnel portal, a securely gated pedestrian access route, preferably step-free, should be provided between the service building and the nearest portal, for use by maintenance staff.

## 13. Normative references

The following documents, in whole or in part, are normative references for this document and are indispensable for its application. For dated references, only the edition cited applies. For undated references, the latest edition of the referenced document (including any amendments) applies.

Ref.	Document
Ref 1.N	European Council. 2017/164/EU, '4th Indicative Occupational Exposure Limit Values Directive'
Ref 2.N	Europa.eu. 2008/50/EC, 'Ambient air quality and cleaner air for Europe'
Ref 3.N	National Highways. CS 454, 'Assessment of highway bridges and structures'
Ref 4.N	BSI. BS EN 1125, 'Building hardware – Panic exit devices operated by a horizontal bar, for use on escape routes – Requirements and test methods (Designated Standard - CPR)'
Ref 5.N	National Archives. UKSI 2011/1885, 'Carriage of Dangerous Goods and Use of Transportable Pressure Equipment (Amendment) Regulations'
Ref 6.N	Assets publishing service. DEFRA - Department for Environment, Food and Rural Affairs. CAS 2019, 'Clean Air Strategy 2019'
Ref 7.N	BSI. BS 5228 [All Parts], 'Code of practice for noise and vibration control on construction and open sites'
Ref 8.N	BSI. BS 7430, 'Code of practice for protective earthing of electrical installations'
Ref 9.N	BSI. BS 5489-1, 'Code of practice for the design of road lighting: Lighting of roads and public amenity areas'
Ref 10.N	BSI. BS 5489-2, 'Code of Practice for the Design of Road Lighting: Lighting of Tunnels'
Ref 11.N	BSI. BS EN ISO 9223, 'Corrosion of metals and alloys - Corrosivity of atmospheres - Classification, determination and estimation'
Ref 12.N	National Highways. CD 127, 'Cross-sections and headrooms'
Ref 13.N	BSI. BS EN 62262, 'Degree of protection provided by enclosures for electrical equipment against external mechanical Impacts (IK code)'
Ref 14.N	BSI. BS EN 60529, 'Degrees of protection provided by enclosures (IP code). (Designated Standard - LVD)'
Ref 15.N	BSI. BS 7445-1, 'Description and measurement of environmental noise. Guide to quantities and procedures'
Ref 16.N	National Highways. CD 143, 'Designing for walking, cycling and horse riding'
Ref 17.N	BSI. BS EN 12217, 'Doors. Operating forces. Requirements and classification.'
Ref 18.N	National Highways. CD 522, 'Drainage of runoff from natural catchments'
Ref 19.N	Europa.eu. EC/640/2009, 'Eco-design Requirements for Electric Motors'
Ref 20.N	Europa.eu. 2014/30/EU, 'Electromagnetic Compatibility (EMC) Directive'
Ref 21.N	BSI. BS EN 50172, BS 5266-8, 'Emergency escape lighting systems'
Ref 22.N	BSI. BS EN 50172, 'Emergency escape lighting systems.'
Ref 23.N	BSI. BS 5266 [All Parts], 'Emergency escape lighting systems.'
Ref 24.N	National Archive. UKPGA 2010/15, 'Equality Act'

Ref 25.N	BSI. BS EN ISO 9241 [All Parts], 'Ergonomics of human-system interaction'
Ref 26.N	BSI. BS EN 1993-1-2, 'Eurocode 3: Design of Steel Structures'
Ref 27.N	BSI. BS EN 16276, 'Evacuation Lighting in Road Tunnels'
Ref 28.N	BSI. BS EN 60079-10-1, 'Explosive atmospheres. Classification of areas. Explosive gas atmospheres.'
Ref 29.N	BSI. BS EN 54 [All parts], 'Fire detection and fire alarm systems [Some parts harmonised. Note: HEn & DS have diverged in Parts 5 & 7]'
Ref 30.N	BSI. BS 5306-3, 'Fire extinguishing installations and equipment on premises. Commissioning and maintenance of portable fire extinguishers. Code of practice '
Ref 31.N	BSI. BS 5041-1 , 'Fire hydrant systems equipment. Specification for landing valves for wet risers'
Ref 32.N	BSI. BS EN 694, 'Fire-fighting hoses. Semi-rigid hoses for fixed systems'
Ref 33.N	BSI. BS EN 12094 [All parts], 'Fixed firefighting systems – Components for sprinkler and water spray systems (some parts harmonised)'
Ref 34.N	BSI. BS EN 671-1, 'Fixed firefighting systems. Hose systems. Hose reels with semi-rigid hose (Designated Standard - CPR)'
Ref 35.N	BSI. BS EN 61508-2, 'Functional safety of electrical/electronic/ programmable electronic safety-related systems. Requirements for electrical/electronic/ programmable electronic safety-related systems'
Ref 36.N	BSI. BS EN 61508 [All Parts], 'Functional Safety of electrical/electronic/programmable electronic safety related systems'
Ref 37.N	BSI. BS 8233, 'Guidance on sound insulation and noise reduction for buildings.'
Ref 38.N	National Highways. CD 109, 'Highway link design'
Ref 39.N	PIARC. PIARC Technical Report R17, 'Human Factors and Road Tunnel Safety Regarding Users'
Ref 40.N	Department for Transport. <a href="https://www.gov.uk/government/publications/inclusive-mobility-making-transport-accessible-for-passengers-and-pedestrians">https://www.gov.uk/government/publications/inclusive-mobility-making-transport-accessible-for-passengers-and-pedestrians</a> . Inclusive Mobility, 'Inclusive mobility - A guide to best practice on access to pedestrian and transport infrastructure'
Ref 41.N	National Highways. CS 452, 'Inspection and records for road tunnel systems'
Ref 42.N	National Highways. GG 101, 'Introduction to the Design Manual for Roads and Bridges'
Ref 43.N	BSI. BS EN 12464-1, 'Light and lighting. Lighting of work places. Indoor work places.'
Ref 44.N	BSI. BS EN 1838, 'Lighting Applications. Emergency lighting'
Ref 45.N	BSI. BS EN 61439-2, 'Low-voltage switch gear and control gear assemblies. Power switch gear and control gear assemblies (Designated Standard - LVD)'
Ref 46.N	BSI. BS EN 60598 (All parts), 'Luminaires.(Some parts harmonised)'
Ref 47.N	BSI. BS EN 794, 'Lung Ventilators'
Ref 48.N	BSI. BS EN 62682, 'Management of alarms systems for the process industries'
Ref 49.N	BSI. BS 4142, 'Methods for rating and assessing industrial and commercial sound'

Ref 50.N	PIARC. PIARC R05, 'PIARC Report 2012 R05 EN Road Tunnels: 'Vehicle Emissions and Air Demand for Ventilation 2012 '
Ref 51.N	Energy Networks Association. G5/4-1, 'Planning levels for harmonic voltage distortion'
Ref 52.N	BSI. BS EN 3-10, 'Portable fire extinguishers. Provisions for evaluating the conformity of a portable fire extinguisher to EN 3-7'
Ref 53.N	BSI. BS EN 62305 [All parts], 'Protection against lightning'
Ref 54.N	BSI. BS EN 62305-4, 'Protection against lightning. Electrical and electronic systems within structures'
Ref 55.N	BSI. BS 7671, 'Requirements for Electrical Installations. IET Regulations' , 2018
Ref 56.N	National Highways. CD 377, 'Requirements for road restraint systems'
Ref 57.N	National Highways. LA 113, 'Road drainage and the water environment'
Ref 58.N	National Highways. TD 501, 'Road lighting design'
Ref 59.N	National Archives. UKSI 2009/64, 'Road Tunnel Safety (Amendment) Regulations'
Ref 60.N	Gov UK. UKSI 2009/64 dup, 'Road Tunnel Safety Regulations 2007 and the Road Tunnel Safety (Amendment) Regulations 2009'
Ref 61.N	National Highways. TD 131, 'Roadside technology and communications'
Ref 62.N	BSI. IEC. BS EN 60034-30-1, 'Rotating electrical machines. Efficiency classes of line operated AC motors (IE code)'
Ref 63.N	BSI. BS 5499-4, 'Safety signs. Code of practice for escape route signing'
Ref 64.N	BSI. BS 8519, 'Selection and installation of fire-resistant power and control cable systems for life safety and fire-fighting applications'
Ref 65.N	BSI. BS EN 858-1, 'Separator systems for light liquids (e.g. oil and petrol): Principles of product design, performance and testing, marking and quality control'
Ref 66.N	BSI. BS EN 12101-3, 'Smoke and heat control systems. Specification for powered smoke and heat control ventilators (Fans) (Designated Standard - CPR)'
Ref 67.N	BSI. BS EN IEC 60268-16, 'Sound system equipment. Objective rating of speech intelligibility by speech transmission index'
Ref 68.N	National Highways. CD 526, 'Spacing of road gullies'
Ref 69.N	Institute of Electrical and Electronics Engineers. IEEE C37.1, 'Standard for SCADA and Automation Systems'
Ref 70.N	National Highways. CG 300, 'Technical approval of highway structures'
Ref 71.N	National Archives. UKSI 2010/2214, 'The Building Regulations'
Ref 72.N	National Archives. UKSI 2005/1643, 'The Control of Noise at Work Regulations'
Ref 73.N	National Archives. UKSI 2002/2776, 'The Dangerous Substances and Explosive Atmospheres Regulations'
Ref 74.N	National Highways. CD 192, 'The design of crossovers and changeovers'
Ref 75.N	Europa.eu. 2014/34/EU, 'The Equipment and Protective Systems Intended for Use in Potentially Explosive Atmospheres Regulations (ATEX)'
Ref 76.N	National Archives. UKSI 2005/1541, 'The Regulatory Reform (Fire Safety) Order'

Ref 77.N	National Archives. UKSI 2007/1520, 'The Road Tunnel Safety Regulations'
Ref 78.N	National Archive. UKSI 2016/362 (TSRGD), 'The Traffic Signs Regulations and General Directions'
Ref 79.N	National Archives. UKSI 1992/3004, 'The Workplace (Health, Safety and Welfare) Regulations'
Ref 80.N	National Highways. TS 101, 'Traffic signalling systems (inspection and assessment)'
Ref 81.N	Department for Transport (UK). TAG Unit A3, 'Transport Appraisal Guidance Unit A3 user and provider impacts'
Ref 82.N	BSI. BS EN 14339, 'Underground fire hydrants (Designated Standard - CPR)'
Ref 83.N	BSI. BS EN 12966, 'Variable message traffic signs' , 2014+A1:2018
Ref 84.N	National Highways. GG 142, 'Walking, cycling and horse-riding assessment and review'
Ref 85.N	National Archives. UKPGA 1991/56, 'Water Industry Act'
Ref 86.N	Health and Safety Executive. HSE EH40, 'Workplace Exposure Limits'

## 14. Informative references

The following documents are informative references for this document and provide supporting information.

Ref.	Document
Ref 1.1	ADR Agreement, 'ADR Agreement (European agreement concerning the international carriage of dangerous goods by road).'
Ref 2.1	Association of Petroleum and Explosive Administration - APEA. APEA Blue Book, 'APEA Guidance for the Design, Construction, Modification, Maintenance and Decommissioning of Filling Stations'
Ref 3.1	National Highways. CG 302, 'As-built, operational and maintenance records for highway structures'
Ref 4.1	OG-Incidents, 'Communities and Local Government document Fire & Rescue Service: Operational Guidance - Incidents in Tunnels and Underground Structures'
Ref 5.1	DCLG Fire safety risk, 'Department for Communities and Local Government publication 'Fire Safety Risk Assessment – Transport Premises and Facilities'
Ref 6.1	Safe and reliable tunnels symposium, Lausanne, Switzerland, May 2006. Ingason, H. . Ingason 2006, 'Design Fires in Tunnels '
Ref 7.1	Transport Research Laboratory. Unpublished Project Report. TRL UPR/IE/31/06, 'Impact of Revised HSE NOX Standards on Road Tunnels: Report 1: Current Practices for Limiting Exposure to NO and NO2 in Road Tunnels, dated March 2007.'
Ref 8.1	Transport Research Laboratory. Unpublished Project Report. TRL UPR/IE/113/07 , 'Impact of Revised HSE NOX Standards on Road Tunnels: Report 2: Recommended Target Exposure Levels for UK Road Tunnels"
Ref 9.1	Mott MacDonald. HSE NOX, 'Impact of Revised HSE NOX Standards on Road Tunnels: Report 5: Implications of Compliance'
Ref 10.1	National Highways. CS 450, 'Inspection of highway structures'
Ref 11.1	International Commission on Illumination (CIE)/PIARC. CIE 66:1984, 'Joint Technical Report CIE66:1984 'Road Surfaces and Lighting'
Ref 12.1	National Highways. CM 430, 'Maintenance of road tunnels'
Ref 13.1	Europa.eu. 2004/54/EC, 'Minimum safety requirements for tunnels in the Trans-European Road Network'
Ref 14.1	British Tunnelling Society. NO: Best Practice Guide, 'Occupational Exposure to Nitrogen Monoxide in a Tunnel Environment: Best Practice Guide'
Ref 15.1	Transport Research Laboratory. TRL PR/SE/746/03, 'Road Tunnel Air Pollution Monitoring'
Ref 16.1	OECD with PIARC. Safety in Tunnels, 'Safety in Tunnels - Transport of Dangerous Goods Through Road Tunnels'
Ref 17.1	International Commission on Illumination (CIE). CIE 140:2002, 'Technical Report CIE140:2002 'Road Lighting Calculations"

## Appendix A. Planning safety and general design

### A1 Establishment of tunnel profile

Planning constraints and ground conditions may well determine the tunnel location and choice of tunnel construction method, which will in turn determine the structural form of a road tunnel and the consequent space available for tunnel equipment. A rectangular cross-section, as found in cut-and-cover or immersed tube tunnels is normally regarded as the most space-efficient, since it can follow closely the required traffic clearance envelope. However, this advantage may be negated by the need to increase the cross-section if jet fans or large direction signs are to be accommodated.

#### A1.1 Service tunnels

Where land availability and funding permit and planned maintenance constraints make desirable, then a separate service tunnel, adjacent to the live traffic tunnels, may be provided on a whole-life cost basis, for providing access on maintenance demand to service cabling and other operating equipment, without requiring a tunnel closure. Such tunnels may also be used for evacuation purposes during an emergency. Other advantages include their use as an exploratory (pilot) tunnel in advance of main tunnel construction.

#### A1.2 Space for equipment

The space between the maintained headroom and the profile set by the structural lining or secondary cladding of the tunnel is available for the equipment required for the tunnel environment. If such space is not used efficiently to suit the equipment required, any enlargement of the tunnel cross-section will lead to significant increase in cost. In rectangular tunnels, the upper corners may be haunched to benefit structural efficiency but this could be a disbenefit in regard to the space and optimal location of equipment.

Electrical and mechanical equipment location in the tunnel and ease of access can have a significant effect on ongoing maintenance costs and the number of traffic lanes requiring closure.

There may be benefits in allowing space for the possible future installation of additional equipment, for examples fixed firefighting systems or more advanced traffic control and monitoring equipment.

#### A1.3 Space requirements for ventilation

Ventilation can have a considerable influence on space requirements, depending on the system chosen.

It is important for tunnels to be as aerodynamically efficient as possible. Naturally and mechanically ventilated tunnels, with one-way traffic, partly rely for ventilation upon the vehicle induced air flow. This effect can be maximised, for a given size of tunnel, if the tunnel interior surface is as smooth as possible and abrupt changes in cross-section, particularly at air entry/exit points, are avoided.

Exhaust fumes / gases can impact on neighbours and prevailing wind effects.

In the event of a fire within a tunnel, the hot air and smoke will form a layer at ceiling level, moving outwards from the source and leaving a zone of clear air beneath it for a distance either side of the source. Downstands from the ceiling and other obstructions might break up this layer and prematurely fill the tunnel with smoke, obstructing escape and rescue.

Ducted ventilation systems may have shafts and adits connecting fan rooms to the main ducts within the tunnel. It is good practice to make these smooth internally and any bends or junctions as aerodynamically efficient as possible. Installation of cables, brackets, ladders and other obstructions to air movement in air shafts should be avoided as they could impair performance and contribute to fan stall.

Space requirements for longitudinal ventilation, using jet fans, normally has little effect on the geometry of arch roofed tunnels providing the fan diameters are kept below 1.5m diameter and the fans are placed over the carriageway lanes within the equipment gauge, rather than above the verges. In the

case of rectangular tunnels, one solution is to increase the height of the tunnel over its full or partial length to accommodate the fans. Where constraints or increased construction costs preclude this solution, fans can be placed in aerodynamically shaped recesses (niches) in the soffit or at the tops of the side walls. However, ventilation efficiency may be reduced and significantly so for the latter, which may have an adverse impact on efficiency and whole life costs.

Where transverse or semi-transverse ventilation is included in tunnels with arched or circular tunnel geometry the space above the traffic envelope or below the road deck can be used for air ducts, thus minimising the influence on required tunnel geometry. However where required volumes of ventilation air are greater than can be accommodated within these spaces, an increase in tunnel structure size will be required to accommodate the necessary supply/exhaust ducting.

In rectangular cross-section tunnels, transverse and semi-transverse systems have a significant effect on tunnel geometry, requiring a greater tunnel height and/or increased width to accommodate the necessary ducting.

Regardless of tunnel cross-sectional profile transverse and semi-transverse ventilation systems require ancillary air ducts, ventilation shafts and ventilation plant rooms/buildings.

The location of ventilation air intake and exhaust points may also have important environmental consequences, addressing which can significantly affect the ventilation space requirements within the tunnel.

Space requirements for longitudinal ventilation systems using Saccardo nozzles to inject air into the tunnel normally have little impact on the geometry of arched or rectangular profile tunnels, but will require ventilation buildings and large nozzle structures connecting with the tunnel. Saccardo systems are inherently unidirectional, so if reversible ventilation is needed ventilation buildings will be required at either end of each tunnel bore.

#### **A1.4 Space requirements for drainage**

Identification of requirements for portal and low-point drainage sumps and pumping plant early in the design process will need to establish if they are likely to have an impact on the structural design of the tunnel. This is particularly important for low-point sumps in immersed tube tunnels, where the sump and its associated pumping and ventilation plant will need to be accommodated within the immersed tube structure and may be the principal determinant of the cross-sectional dimensions. Sufficient allowance will need to be made for installation and removal of equipment, access for cleaning and inspection, the required working volume and efficient deployment of a fire-suppression system.

#### **A1.5 Space requirements for lighting**

Generally tunnel lighting has little bearing on the tunnel geometry. In arched roof profiles, without false ceilings or ventilation duct soffits, there is normally ample space for luminaires. Only arched tunnels with false ceilings and rectangular profiled tunnels, where the luminaires are located above the traffic lanes, require vertical space of between 350 mm and 500 mm to accommodate the 250 mm additional clearance and the luminaires themselves.

#### **A1.6 Space requirements for signs and signals**

Signalling equipment, if located on the side walls, has little influence on the cross section of arched tunnels, with two lanes, or of rectangular tunnels. However, consideration should be given to the possibility that visibility of signs and signals in this location may be obscured by vehicles in the adjacent traffic lane.

Where standard lane control signals are fitted over the traffic lanes, about 600 mm vertical height is normally needed to accommodate the 250 mm additional clearance and the signs themselves.

Full sized direction signs may be difficult to locate within a tunnel and are best positioned outside of the portals.

**A1.7 Space for loudspeakers**

Where a public address and/or voice alarm system using flared-horn type loudspeakers is to be installed in the tunnel, about 600 mm vertical height is needed to accommodate the 250 mm additional clearance and the loudspeakers themselves.

**A1.8 Tunnel service buildings & tunnel portals**

Substations, plant rooms, control centre, and similar service requirements. are normally housed in service buildings. Their number and location will be dictated by the requirements of the electrical distribution system (that is as close as possible to the tunnel to avoid excessive voltage drop), by the type of ventilation system and by land availability.

The footprint of each service building can vary significantly according to the equipment and facilities to be accommodated. Any or all of the following may be required:

- 1) HV switchgear, metering equipment and transformers associated with the incoming electricity supplies;
- 2) standby generators, control panels and fuel storage tanks (if located internally);
- 3) LV switchgear associated with the tunnel power distribution system;
- 4) motor control centres for ventilation and other mechanical plant;
- 5) uninterruptible power supply units and battery racks;
- 6) equipment rooms for monitoring, control and communications equipment;
- 7) ventilation and air conditioning plant;
- 8) local control room;
- 9) office and welfare facilities for use by maintenance staff;
- 10) adequate provision for vehicular access, parking and turning space;
- 11) water tanks for firefighting systems;
- 12) heating, ventilation and/or air conditioning plant to regulate room temperatures, particularly in UPS rooms, battery rooms and areas containing electronic equipment.

Open road-drainage sumps should be located clear of service buildings because of the inherent dangers of electrical equipment in close proximity to explosive gases from spills, fumes and similar.

For habitable buildings, the requirements of the relevant building regulations, fire regulations, The Equality Act [ UKPGA 2010/15 [Ref 24.N] and other relevant regulations will apply.

The need for a tunnel service building to fit into its surroundings should not result in the provision of less than adequate space for housing necessary equipment. Service buildings are part of the complete tunnel and highway scheme and are not treated as a separate development.

For safety, wherever possible vehicular access to service buildings should not be provided directly from the tunnel approaches.

**A1.9 Space requirements for secondary cladding and passive fire protection**

Where secondary cladding or passive fire protection, in the form of a spray applied mortar or a prefabricated board system, is to be installed, allowance will need to be made for the thickness of the materials and any supporting system when calculating the maintained headroom and clearance envelopes as described in Section 4 'Geometric design.'

Secondary cladding usually constitutes an additional layer of lightweight construction, placed over the internal face of the primary (main load-bearing) lining. The main functions of secondary cladding are to provide a low-specularity reflective surface to assist tunnel lighting; to smooth the interior of the tunnel to facilitate mechanical cleaning of the tunnel walls; to reduce ventilation energy losses and to shed drips to drainage in the case of seepage through the primary tunnel lining. It also may provide a beneficial effect, where anti-drumming layers are added, on noise levels within the tunnel. Where the

secondary cladding is used to blank off dead space within the tunnel, it has minimal effect on the cross section. Internal finishes to the tunnel structure, visible to the travelling public, should be attractive and functional without being distracting to safe driving, unless specifically designed to beneficially influence driver behaviour.

Design should allow ease of removal for structural inspections and replacement following damage.

### **A1.10 Space requirements for cabling, pipework and ducted services**

The provision of space for ducts to contain and protect from fire the cabling for tunnel M&E functions, and possible future services, will have a significant impact on certain types of tunnel structure. As well as space for the ducts and pipes themselves, consideration will need to be given to the accommodation of associated cable draw pits, joints, valve chambers, crossing points, and similar, which may increase the required cross-section of the route locally.

Where secondary cladding is used, it may be possible to utilise the space between the cladding and the main structure for services; this will normally have to be designed into the original concept.

In long tunnels, derating of cables and pressure drop in piped services can lead to an increased size of these services, and the need for larger ducts to house them. Pressurisation/charging points for piped services may be required. In circular tunnels, duct space is usually available under the roadway by virtue of the tunnel shape. In flat-bottom shape tunnels, however, an increase in depth may be required to locate the cabling and/or pipework beneath the walkway zone. Manhole and other duct covers within the traffic lanes can be prone to damage and tunnel closures are likely to be needed for access to maintain or replace loosened covers etc.

### **A1.11 Utilities**

The construction of a road tunnel may offer opportunities to owners of utilities and communication companies to seek to use the tunnel to carry additional service pipelines, transmitters and cables for the benefit of such companies and their customers. In such instances points to consider include the effect on tunnel safety, operations and maintenance; access to effect repairs or replacements; liability for any curtailing of or damage to services; fire or explosion e.g. from gas leaks; corrosion and heat from high voltage cables; ventilation energy loss from the additional drag caused by the larger diameter pipelines; interference with broadcasting of the emergency and maintenance staff broadcasting frequencies and competition policy.

The development of in-car communications could be of significant benefit to enable tunnel operators to contact and guide road users during a tunnel emergency and to enable drivers to summon assistance without leaving their vehicles. However, the need to discourage use of mobile telephones whilst driving within a tunnel should also be recognised.

## **A2 Tunnel Design and Safety Consultation Group (TDSCG) requirements**

### **A2.1 General**

The Tunnel Design and Safety Consultation Group (TDSCG) discusses and agrees road tunnel design and refurbishment proposals affecting operational requirements in the context of the topics listed below, where applicable to the tunnel under consideration (see Section 2). The list should be regarded as the minimum requirement and is not intended to be exhaustive. Individual tunnels or groups of tunnels may have certain additional features which have a direct bearing on operational safety. Such features need to be added to the list.

### **A2.2 Topic list**

The minimum list of topics for discussion and agreement by the TDSCG is presented in the order of the relevant sections, as follows:

#### **A2.2.1 Planning safety and general design**

Section 2:

- 1) safety and operational effectiveness of the overall systems proposed for the tunnel;
- 2) the consequences of planned and unplanned tunnel closures on the surrounding road network;
- 3) identification of emergency incident and hazard scenarios to be effectively dealt with;
- 4) requirements for the passage of hazardous goods;
- 5) contribution of safety consultation document to the road safety audit;
- 6) personal safety equipment provision, training needs;
- 7) coordination of operating procedures and contingency plans of the police and other emergency services attending an emergency. Consideration of unsigned Rally points/RVPs and routes to them;
- 8) consideration of partial or full loss of any facilities due to fire damage or explosion;
- 9) review of feedback and any necessary follow-up actions resulting from previous emergency incident drills.

Section 3:

- 1) any unusual features of the tunnel, which may give rise to particular hazards;
- 2) the level of provision of emergency panels, stopping lanes, walkways, refuges and escape routes for emergency use;
- 3) the level of provision of communications and firefighting equipment;
- 4) public information for all tunnel users to facilitate their safe usage of the tunnel.

Section 4:

- 1) the siting of signs and gantries;
- 2) the general layout in terms of standby areas at portals, vehicle recovery and cross-over and contraflow arrangements for emergency and maintenance purposes;
- 3) access for police and other emergency services;
- 4) considerations for tunnel users making use of emergency panels/ escape facilities.

Section 5:

- 1) the adequacy of the ventilation system (where provided) to maintain an acceptable air quality during all normal operation and tunnel maintenance scenarios;
- 2) any restrictions that may need to be imposed on traffic or maintenance operations due to limitations of the ventilation system;
- 3) the performance and operation of the ventilation system in all foreseeable fire or emergency situations, including plans for automatic and manual ventilation control, protection of escape routes and safe areas and any assumptions regarding the self-evacuation of tunnel users. Fixed fire fighting systems? Customer behaviour/ Impact on emergency services response / communications?

Section 6:

- 1) cleaning and maintenance regimes and related tunnel closures and traffic orders; and
- 2) adequacy of lighting design for special and emergency operating conditions, including power supply failure.

Section 7:

- 1) the operational assumptions of the inflow rates upon which the design of the drainage system is based, climate change assumptions and impacts;
- 2) the possible results and hazards of abnormal storm conditions exceeding the design criteria;
- 3) the ability of the drainage system to accept and safely contain a hazardous spillage;

- 4) the acceptability of arrangements to discharge storm water and polluted water (e.g. from tunnel cleaning operations or spillages);
- 5) the proposed means of disposing of hazardous or other substances which cannot be discharged normally; and
- 6) arrangements and procedures for inspecting and cleaning pipework and sumps, including procedures for any confined spaces.

Section 8:

- 1) the appropriateness of the facilities described in this section for use by the emergency services when responding to a fire,;
- 2) review of time lines for the detection and development of tunnel fires, evacuation and emergency response; and
- 3) requirements for familiarisation of emergency services personnel with equipment provided for their use.

Section 9:

- 1) communications and control systems, including control of CCTV;
- 2) the adequacy and use of automatic incident detection systems;
- 3) the automatic, static and temporary signing to be provided, in advance of and at the tunnel, for normal, maintenance and emergency traffic operations for the tunnel;
- 4) the requirements for and siting of emergency and smoke control telephones;
- 5) the requirements and provision of equipment for radio rebroadcast facilities for the emergency services, public service radio broadcasting and mobile telephones;
- 6) the use of public address/voice alarm systems, including the precise wording of emergency messages; and
- 7) provisions for removing broken down vehicles and similar from within the tunnel.

Section 10:

- 1) location of local and remote control facilities for day-to-day monitoring and supervision of the tunnel and for emergency response (if different); and
- 2) the possible consequences of failure of part, or all, of the SCADA system and/or data communications network.

Section 11:

- 1) possible hazardous consequences of failure or temporary interruption of the incoming mains supply or a section of the tunnel internal power distribution network;
- 2) security of supplies to essential equipment required to continue operating under mains power failure conditions, including duration requirements; and
- 3) the effect on tunnel operation and safety of disconnection or removal of key items of equipment, such as transformers or circuit breakers, for maintenance or repair.

Section 12:

- 1) any requirements for use of the tunnel service buildings by emergency services, including access and parking arrangements; and
- 2) review of fire alarm and automatic fire extinguisher systems.

### A3 Safety issues

Avoidance wherever possible of the use of materials within the tunnel which give off toxic fumes during a fire will minimise the risk of harm. The accumulation of traffic dust, which often contains toxic substances and is a potential fire risk, in areas difficult to clean on a regular basis, such as within false

ceilings, should be mitigated against. There is a risk that asbestos products such as asbestos cement air duct formers and asbestos rope gaskets between tunnel lining segments may be present in older tunnels and these should be dealt with in accordance with the Overseeing Organisation's Asbestos Management Plan. Any possibly hazardous materials cannot be injected into adjacent ground as they may be of harm to the environment.

Whilst road tunnels provide a drier and more sheltered environment for road users than the open road, the atmosphere within a tunnel can be humid and polluted with dust and acidic gases from vehicle emissions. Such conditions may be aggressively corrosive to any equipment installed within the tunnel. Chlorides, particularly from the use of road salt, have also caused considerable damage to several UK tunnel structures and equipment. Solutions to wash tunnel walls may be caustic in nature. The materials used in the structure and installed equipment should not be adversely affected by tunnel washing solutions or the deicing materials normally used in the area, or recommend the use of suitable alternatives.

Water leakage into tunnels through structural cracks and joints can result in a number of hazardous situations. If it collects in areas with, for example, unprotected electrical equipment there may be a risk of electric shock. Freezing of the water on the carriageway or walkways may lead to slippery surfaces, while thawing may result in the formation of icicles from the tunnel roof and portals that could fall onto road users and increase the rate of deterioration of the structure, particularly around cracks and open joints. Exposed leaks are unsightly and may alarm the public as to the safety of the tunnel structure. Heavy leakage can be costly in energy terms, if additional pumping out of the roadway sumps is required. Any associated lowering of the groundwater table may be environmentally detrimental and/or lead to settlements of adjacent structures. Other hazardous materials may seep in from the ground. The freeze thaw effect. The effect of drips on cable / trunking over time.

Air pollution, arising from the vehicles passing through a road tunnel, is concentrated and exhausted at the tunnel portals and any ventilation shafts. For environmental reasons, in locations with adjacent inhabited buildings, it may be necessary to provide additional forced ventilation so that the polluted air being expelled has sufficient velocity and turbulence to mix and distribute with the ambient air, so that ambient air pollution regulation levels are not exceeded. It will normally be necessary, in such cases, to establish the average background level of the ambient air pollution at an early stage. For site readings, exhausted air from the tunnel should be measured at the nearest inhabited building which is not part of the tunnel operation or 100 m from the portal or the point of issue, whichever is the lesser. Reference may be made to PIARC R05 [Ref 50.N] mathematical formulae to estimate tunnel dispersion distances, but physical scale models are presently believed to be more reliable for predictions in areas of complex topography and infrastructure.

#### **A4 Planning for emergencies**

Two broad situations influence the planning for emergencies. The more common event is a vehicle incident or breakdown which causes a degree of lane blockage, and consequential restriction or even temporary loss of use of the tunnel. The resulting delays may rapidly extend to the surrounding road network. Prompt remedial action is then called for to restore free flow and minimise the congested conditions that, in themselves, can aggravate the risk of further breakdown and/or incidents. The second situation involves collision and possible fire or explosion, and is potentially more dangerous for the tunnel user and requires a rapid response from the emergency service.

#### **A5 ADR (Accord Dangereux Routier) (European regulations concerning the international transport of dangerous goods by road)**

The ADR Agreement [Ref 1.I] specifies a simplified system of grouping tunnels in categories A to E and corresponding signage to be used to indicate the goods that can be safely transported through a tunnel. These are summarised as follows:

Group A: No restrictions on dangerous goods permitted for carriage on the public road network

Group B: No restrictions except for goods likely to cause a large explosion

Group C: As for B, plus restrictions on goods with a risk of a medium explosion or a large toxic gas or liquid release

Group D: As for C, plus restrictions for goods with a risk of a large fire

Group E: All regulated dangerous goods prohibited.

In considering restrictions for any of groups B to E, the final decisions should take into account the risks associated with diverting dangerous goods traffic along alternative routes, for which the risks may be greater than for the tunnel. A risk assessment methodology and decision support model designed for this purpose can be found in the OECD/PIARC report 'Safety in Tunnels – Transport of Dangerous Goods Through Road Tunnels' published in 2001 Safety in Tunnels [Ref 16.]. (Note, however, that the use of the Excel-based DG-QRAM software made available by PIARC to accompany this report is not recommended since it is incompatible with current versions of Microsoft Excel and is no longer supported).

A tunnel will, by default, be assumed to be in Group A, unless agreed otherwise with the Overseeing Organisation. Appropriate measures need to be in place to ensure safety in the event of any incident involving dangerous goods. Compliance with the consequent restrictions so imposed may be difficult to enforce. Where it is proposed to impose restrictions on dangerous goods traffic, the Overseeing Organisation will need to be notified and appropriate signage erected.

## A6 Wall finishes

The choice of wall or cladding finishes can have a significant impact on the tunnel lighting design, and will need to be considered at an early stage in the design process. High gloss textured finishes can result in undesirable and confusing specular (mirror like reflection without diffusion) and glare problems from daylight, vehicle stop lamps and traffic signs. Specular reflection from vehicle headlights is particularly disadvantageous when two-way traffic flow is in operation.

The acoustic properties of the wall finishes or cladding can affect reverberation within the tunnel. This is particularly significant if compatibility with the loudspeakers of a public address/voice alarm system is required.

Materials for lining panels will need to be considered carefully and sandwich compounds materials should not amplify neither heat nor vibration through their body or connections, fixings or areas of interaction. Detail of sandwich materials and the individual and compound properties will need to be clearly proposed before installation, and recorded in the O&M manual

Colour schemes are normally as follows:

- 1) light colours from road surface level up to the 4-metre line;
- 2) darker colours above the 4-metre line including the roof space;
- 3) The dark colour area above the 4-metre line serves three functions:
  - a) In the case of a circular/horseshoe shaped tunnel it avoids the claustrophobic reflective tube effect, which can be disturbing to drivers in long tunnels, and replaces it with a tunnel of visual rectangular appearance, giving apparent width to the tunnel;
  - b) It obscures the hardware installed above the luminaires and improves the aesthetic appearance;
  - c) It provides a visual limit for the wall cleaning machine and hides a soiled appearance where the surface is not cleaned.

High wall diffused light reflectivity contributes to the luminaire light distribution onto the road surface.

## Appendix B. Drainage

### B1 Factors influencing groundwater inflows into tunnels

The quantity of groundwater flowing into a tunnel is dependent on the ground conditions, and the design and construction quality of the tunnel structure. Some of the common factors are:

- 1) Tunnels beneath the water table: water inflow into a tunnel will depend upon the waterproofing system used. Even with a full waterproofing system some inflow may occur. Substantially larger inflows are experienced where tunnels incorporate specific measures to drain the groundwater and lower the water table;
- 2) Tunnels above the water table: tunnels in this category may experience only intermittent water inflow from rainfall seepage, or from leaking or burst water pipes or sewers local to the tunnel;
- 3) All local features, including all water bodies, topographical features, wells, tidal/inter-tidal features as part of the hydro-geological model for the tunnel design.

© Crown copyright 2024.

You may re-use this information (not including logos) free of charge in any format or medium, under the terms of the Open Government Licence. To view this licence:

visit [www.nationalarchives.gov.uk/doc/open-government-licence/](https://www.nationalarchives.gov.uk/doc/open-government-licence/),  
write to the **Information Policy Team, The National Archives, Kew, London TW9 4DU**,  
or email [psi@nationalarchives.gsi.gov.uk](mailto:psi@nationalarchives.gsi.gov.uk).



Highway Structures & Bridges  
Design

## CD 352 - ENAA

# England National Application Annex for Design of road tunnels

(formerly BD 78/99)

Version 0.0.1

### **Summary**

This National Application Annex sets out the National Highways-specific requirements for a high level governance process for ensuring the tunnel solutions proposed are appropriate taking accounts of best operational practice and collected experience.

### **Feedback and Enquiries**

Users of this document are encouraged to raise any enquiries and/or provide feedback on the content and usage of this document to the dedicated National Highways team. The online feedback form for all enquiries and feedback can be accessed at: [www.standardsforhighways.co.uk/feedback](https://www.standardsforhighways.co.uk/feedback).

**This is a controlled document.**

<b>Release notes</b>	<b>2</b>
<b>Foreword</b>	<b>3</b>
Publishing information . . . . .	3
Contractual and legal considerations . . . . .	3
<b>Introduction</b>	<b>4</b>
Background . . . . .	4
Role of the TDA . . . . .	4
Assumptions made in the preparation of this document . . . . .	5
<b>Abbreviations</b>	<b>6</b>
<b>Terms and definitions</b>	<b>7</b>
<b>E/1. Scope</b>	<b>8</b>
<b>E/2. Normative references</b>	<b>9</b>
<b>E/3. Informative references</b>	<b>10</b>
<b>Appendix E/A. Review process for tunnel solutions</b>	<b>11</b>
<b>Appendix E/B. TDA review: PCF product sign-off</b>	<b>15</b>
E/B1 PCF product sign-off forms . . . . .	15
E/B1.1 Record of issue . . . . .	15
E/B1.2 Consulted with . . . . .	15
E/B1.3 PCF quality control . . . . .	15
E/B1.4 FIRST ISSUE . . . . .	16
E/B2 Records . . . . .	21

## Latest release notes

Document code	Version number	Date of publication of relevant change	Changes made to	Type of change
CD 352 - ENAA	0.0.1	November 2024	England NAA	Incremental change to notes and editorial updates

Version 0.0.1:Revision 1 (Publication: November 2024) Rebranding from Highways England to National Highways. Revision 0 (March 2020) Highways England National Application Annex to CD 352 covering the Tunnel Design Authority for Highways England. The main purpose of the Tunnel Design Authority process is to provide a formal route for engagement with those responsible for operation/management and maintenance from the outset of the scheme development.

## Previous versions

Document code	Version number	Date of publication of relevant change	Changes made to	Type of change
CD 352	0	March 2020		

## **Foreword**

### **Publishing information**

This document is published by National Highways.

This document supplements the replacement for BD 78/99, which is withdrawn.

### **Contractual and legal considerations**

This document forms part of the works specification. It does not purport to include all the necessary provisions of a contract. Users are responsible for applying all appropriate documents applicable to their contract.

## Introduction

### Background

This National Application Annex gives the National Highways-specific requirements for a Tunnel Design Authority for high-level review and direction of design solutions.

The Tunnel Design Authority (TDA), is a central overseeing group previously established by Highways England.

The group brings together experience and capability to achieve a consistent approach in the planning and design of tunnel schemes, for a new road tunnel or for refurbishment of an existing road tunnel, thereby driving improvement, consistency and best practice through the design stages of tunnel schemes, in order to deliver the best operating product.

The main purpose is to provide a formal route for engagement with those responsible for operation/management and maintenance from the outset of the scheme development.

The group is chaired by National Highways (NH) Chief Highway Engineer with the following representatives from within National Highways and external organisations with road tunnel expertise:

- 1) Chair - Chief Highway Engineer;
- 2) NH tunnel managers;
- 3) NH Operations Directorate;
- 4) NH technology and tunnels teams;
- 5) tunnel suppliers/designers (representatives from each current tunnel project);
- 6) additional construction expertise;
- 7) external experts (from other organisations; for example: Transport for London, Network Rail, Crossrail, and UK Tunnel Operators Forum);
- 8) expertise/input from existing networks as required; for example: Rijkswaterstaat (RWS) - the Netherlands, Agentsschap Wegen & Verkeert (AWV) - Belgium, Centre d'Etudes des Tunnels (CETU) - France.

TDA reviews of tunnel proposals will commence from PCF (Project Control Framework) Stage 0 and continue for each gate through to Stage 7. Intermediate reviews on specific tunnel aspects will be arranged as necessary. Review outputs will be signed off by the National Highways Chief Highways Engineer.

TDA is not a technical approval body. It does not replace or duplicate the technical approval process. The TDA output report will be taken into account by the TAA.

### Role of the TDA

The TDA will be a high level governance group. It will:

- 1) provide recommendations to SRO's through a process of formally recorded reviews and high level direction for the design of tunnel solutions (see process flowchart in Appendix A);
- 2) ensure that National Highways has the necessary technical capability in place, promotes appropriate knowledge sharing and learning processes, and gathers best practice and feedback from other UK and worldwide tunnel projects;
- 3) ensure that tunnel technical governance and assurance processes are being applied, and that these processes are subject to ongoing review for continuous improvement.

Individual projects will continue to follow current technical requirements of CD 352. CD 352 requires a Tunnel Design and Safety Consultation Group (TDSCG) to be set up for each tunnel project.

The TDA will not input into contract specific engineering and commercial decisions, unless they are at variance with the high-level established principles.

TDA is not responsible for leading discussion with stakeholders, emergency services and suppliers for specific tunnel projects.

Road tunnel matters relating to design and maintenance are covered in the DMRB document CD 352 [Ref 1.N] and CM 430 [Ref 3.I] respectively with documentation covered in documents CS 452 [Ref 1.I] and CS 450 [Ref 2.I].

### **Assumptions made in the preparation of this document**

The assumptions made in GG 101 [Ref 2.N] apply to this document.

## Abbreviations

Abbreviation	Definition
AIP	Approval in Principle
CHARM	Common Highways Agency and Rijswaterstaat model
FFFS	Fixed fire fighting system
HGV	Heavy goods vehicle
PCF	Project control framework
SRO	Senior Responsible Officer
TAA	Technical Approval Authority
TCMS	Tunnel control and management system
TDA	Tunnel Design Authority
TDSCG	Tunnel Design and Safety Consultation Group

## Terms and definitions

### Terms

Term	Definition
Approval in Principle	The document that records the agreed basis and criteria for the detailed design or assessment of a highway structure
Emergency services	All local services that may be called upon to intervene in the event of an incident, including the police, fire and rescue services, ambulance services, traffic officers and tunnel operational staff.
Motorway and all-purpose trunk road network	Collective term to indicate those parts of the UK highway and road network for which National Highways is the highway or road authority.
Technical Approval Authority	The organisation responsible for agreeing the Approval in Principle and acceptance of design and check certification.
Tunnel Design and Safety Consultation Group	A consultation group made up of interested parties, convened for the purpose of reviewing and co-ordinating proposals for the design and operation of a road tunnel.
Tunnel Design Authority	National Highways/Highways England's high level governance group (chaired by Chief Highway Engineer) to provide high-level direction for the design of tunnel solutions.

## **E/1. Scope**

- E/1.1 This National Application Annex provides requirements that shall be complied with in the planning and design of new or major refurbishment of all road tunnels on the motorway and all-purpose trunk road network in England.
- E/1.2 The proposals for a new road tunnel or for refurbishment of an existing tunnel shall be described in the TDA Review PCF (Project Control Framework) Document. See Appendices E/A and E/B.
- E/1.3 TDA advice given shall be complied with.
- E/1.4 The TDA review PCF document shall be signed off by National Highways Chief Highway Engineer prior to preparing the technical approval document for the tunnel.
- E/1.5 A list of the technical reports prepared in support of the tunnel proposal shall be included in the TDA review PCF sign-off document.
- E/1.5.1 As a part of the review, TDA may request submission of any technical reports prepared in developing the tunnel proposals.
- NOTE The TDA output report that forms part of TDA sign-off will be taken into account by the TAA before the AIP is signed by the TAA.*

## E/2. Normative references

The following documents, in whole or in part, are normative references for this document and are indispensable for its application. For dated references, only the edition cited applies. For undated references, the latest edition of the referenced document (including any amendments) applies.

<b>Ref.</b>	<b>Document</b>
Ref 1.N	National Highways. CD 352, 'Design of road tunnels'
Ref 2.N	National Highways. GG 101, 'Introduction to the Design Manual for Roads and Bridges'

### E/3. Informative references

The following documents are informative references for this document and provide supporting information.

<b>Ref.</b>	<b>Document</b>
Ref 1.I	National Highways. CS 452, 'Inspection and records for road tunnel systems'
Ref 2.I	National Highways. CS 450, 'Inspection of highway structures'
Ref 3.I	National Highways. CM 430, 'Maintenance of road tunnels'

## **Appendix E/A. Review process for tunnel solutions**

Figure E/A.1 Flowchart of the review process for tunnel solutions

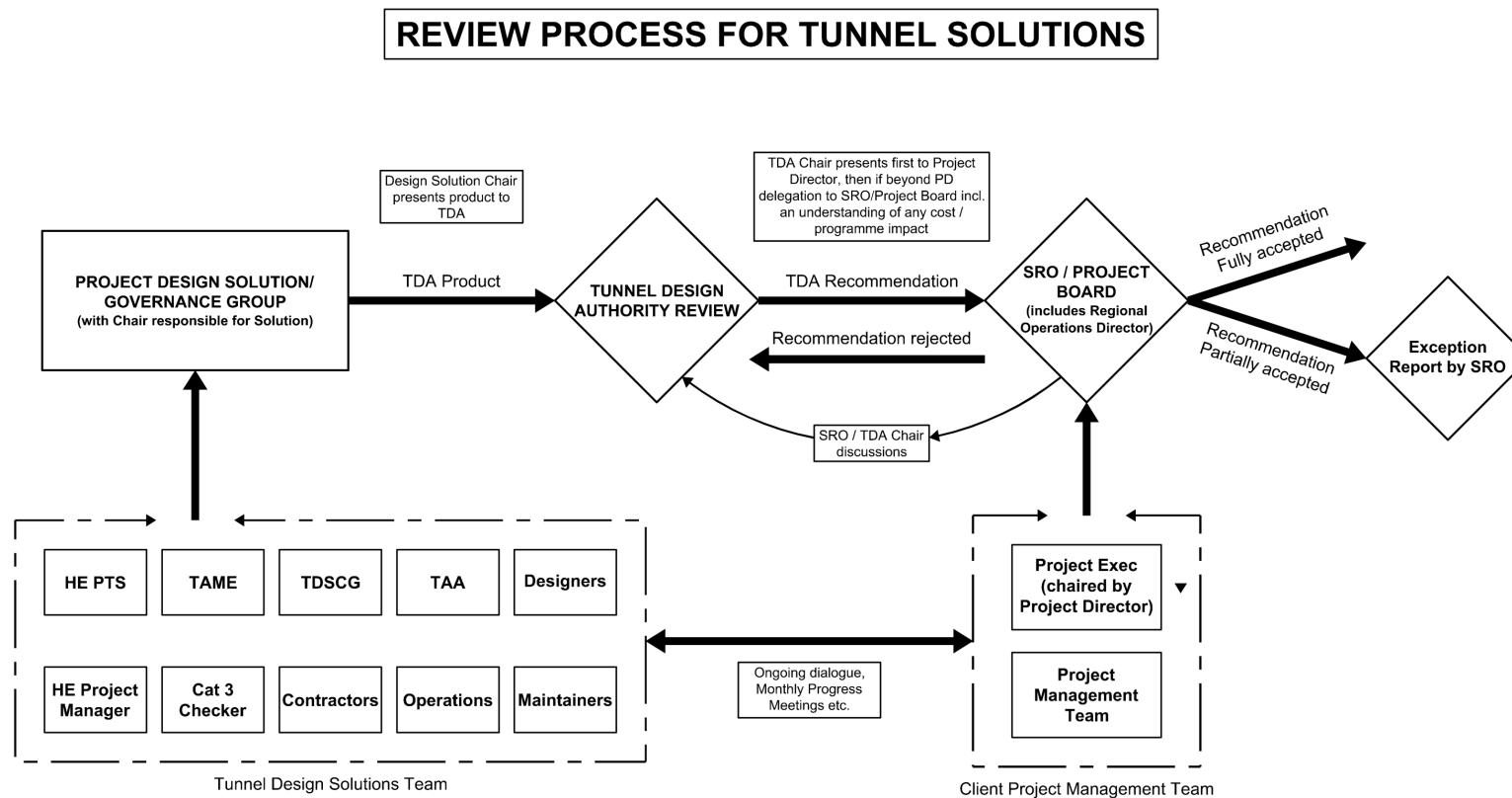
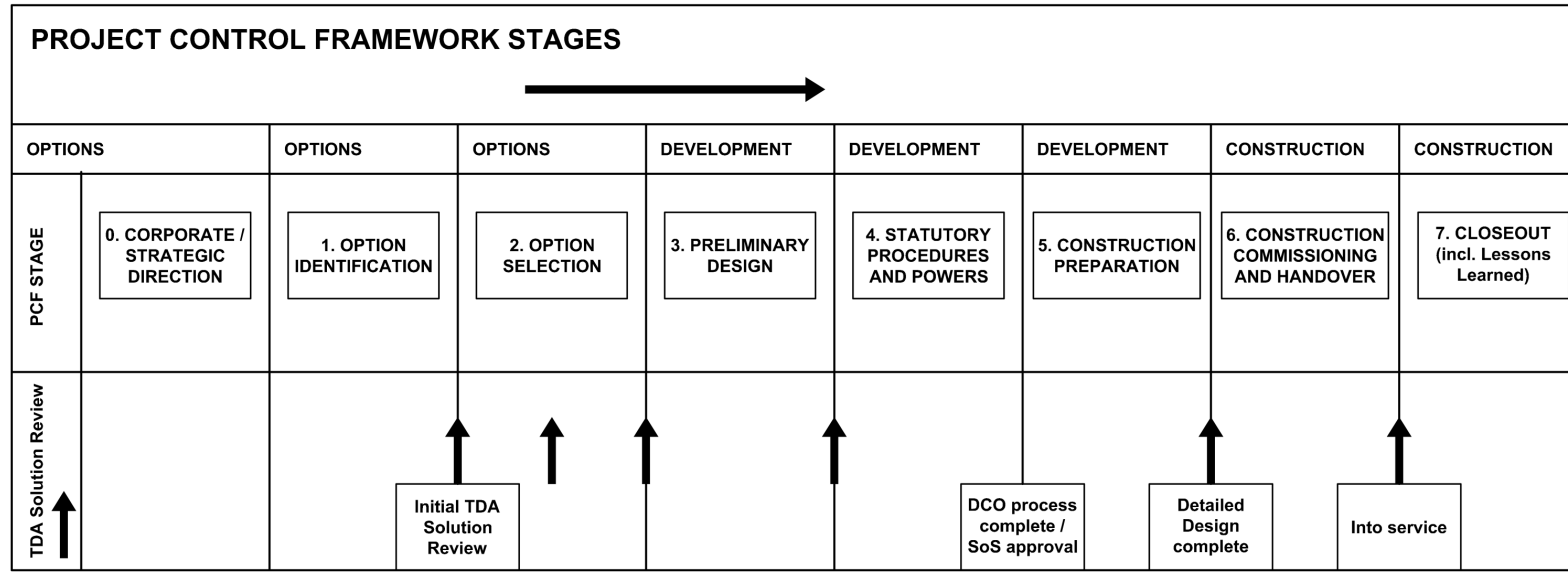

Figure E/A.2 Tunnel project control framework stages





## Appendix E/B. TDA review: PCF product sign-off

### E/B1 PCF product sign-off forms

**Table E/B.1 Summary document and status**

Product title	Summary report for review by Tunnel Design Authority
Produced by (author of the document)	Name
Document status	

#### E/B1.1 Record of issue

**Table E/B.2 Record of issue**

Version	Status	Author	Date	Checked	Date	Authorised	Date

#### E/B1.2 Consulted with

**Table E/B.3 Consulted with**

Name	Role	Date consulted	Date of final comments

#### E/B1.3 PCF quality control

**Table E/B.4 PCF quality control**

Correct title/PCF number displayed on the sign-off sheet and in product?	Y/N
Correct consultee(s) listed?	Y/N
Date consulted /signatures (if appropriate) boxes completed?	Y/N
SRO/sign-off approval name correct?	Y/N
Way we work: is the structure of document in line with the 'way we work' template? (as displayed on National Highways supply chain portal - please attach)	Y/N
Is the format correct & consistent throughout the report and also meets the PCF content requirements?	Y/N
Spelling/grammar check?	Y/N
Are you content that the document is in a satisfactory state for submission to SRO/Sign-off?	Y/N

**Table E/B.5 Any comments**

--

**Table E/B.6 PM/Designer quality sign-off**

Designer representative (product owner)	Name:		Date:		Signed:	
NH Project Manager (product reviewer)	Name:		Date:		Signed:	

Back office use only:

Document on National Highways supply chain portal: Document placed in SHARE (National Highways):

Sign-off sheet placed in SHARE : Power steering updated (National Highways):

**E/B1.4 FIRST ISSUE**

**Table E/B.7 TDA approval form**

1.General
-----------

**Table E/B.7 TDA approval form** (continued)

<p>Name of tunnel / location (include map)</p> <p>New / refurbishment</p> <p>Summary of need for tunnel / problem addressed / scheme brief</p> <p>Traffic flow / % HGVs</p> <p>Route classification, such as 'high load' / CD 352 tunnel classification (based upon length and traffic flow to give the initial view of equipment to be considered for provision)</p> <p>Currently proposed CD 352 tunnel classification</p> <p>Hazardous load categorisation</p> <p>PCF stage (if applicable)</p> <p>Programme - start of works date and opening date</p> <p>Diversion routes; signed traffic speeds</p>
<p>2. Tunnel summary - Space proofing / geometry</p>

**Table E/B.7 TDA approval form (continued)**

<p>Length</p> <p>No. of bores</p> <p>Diameter/size</p> <p>Typical cross section</p> <p>Cross passage - sketches</p> <p>Cross passage spacing</p> <p>Service tunnel provision</p> <p>Running lanes / widths/ lay-bys</p> <p>Verge widths/ hard strips provision</p> <p>Speed limit</p> <p>Connecting roads to tunnel – standard of</p> <p>Emergency stopping lane</p> <p>Ventilation shafts no. / size</p> <p>Access to ventilation shafts</p> <p>Running lanes</p> <p>Portal arrangements</p> <p>Means of escape</p> <p>Access for maintenance</p> <p>Non-motorised user provision</p>
<p><b>3. Construction</b></p> <p>Geology</p> <p>Detailed geology</p> <p>Proposed construction methods</p> <p>Structural options</p> <p>Lining / cladding</p> <p>Key risks</p>
<p><b>4. Fire and life safety</b></p>

**Table E/B.7 TDA approval form** (continued)

<p>Design Fire Load MW rating</p> <p>Fixed fire-fighting systems (FFFS)</p> <p>Hydrants</p> <p>Tanks – locations and sizes</p> <p>Smoke control panels</p> <p>Passive fire protection</p> <p>Automatic fire detection systems</p>
<p>5. Drainage</p> <p>Hydrogeology and ground conditions</p> <p>Control of groundwater</p> <p>During construction</p> <p>During operation</p> <p>Anticipated pump size / provision / sump locations</p> <p>Management of hazardous spillage</p>
<p>6. Mechanical / electrical and public health</p> <p>Power distribution strategy and supplies location</p> <p>Plant rooms</p> <p>Communications system</p> <p>Intelligent transport systems equipment</p> <p>Emergency telephones provision / spacing</p> <p>Lighting provision</p> <p>Tunnel control centre arrangements/ RCC integration</p>
<p>7. Communications /technology</p>

**Table E/B.7 TDA approval form** (continued)

<p>Signing provision - VMS etc</p> <p>Journey time information system</p> <p>Public address system - Voice alarms</p> <p>Control Locations/sizes</p>
<p>8. Ventilation</p>
<p>System planned – longitudinal/semi transverse / fully transverse</p> <p>No. of fans/ locations</p> <p>Maintenance arrangements</p>
<p>9. O and M / systems / controls / co-ordination</p>
<p>Consultation with Operations Directorate – note agreements/ output to date</p> <p>Estimated operational resource levels</p> <p>Estimated running costs (annual)</p> <p>Organisation(s) that will operate and maintain the tunnel</p> <p>Tunnel service building provision</p> <p>Dedicated fire / rescue service?</p> <p>Diversion routes suitability / agreement</p> <p>Suitability for contraflow</p> <p>Queue/ stopped vehicle / incident detection provision</p> <p>Cameras/ monitoring provision</p> <p>Integration with National Highways CHARM/TCMS system</p> <p>Overall safety concept in terms of how incidents are prevented, consequences and emergency situations minimised and designed to support emergency preparedness</p>
<p>10. Emergency services and procedures</p>

**Table E/B.7 TDA approval form** (continued)

Emergency turn-around provision
Crossing points
Escape routes
Cross passages
Emergency stations
Emergency power supplies
Provisions for non-motorised users
Equality impact assessment
Public safety information
Emergency services: response plan

**E/B2**

**Records**

**Table E/B.8 Document information**

Document information:	
Owner:	Date created:
Product advisor:	Date published:
Version:	Date modified:
To be completed when archived:	
Date archived: DD/MM/YYYY	Retain until: DD/MM/YYYY
NB. Not a controlled copy if printed. Only print if absolutely necessary.	

Last reviewed:

Reviewed by:

Members:

Date of next review scheduled for:

© Crown copyright 2024.

You may re-use this information (not including logos) free of charge in any format or medium, under the terms of the Open Government Licence. To view this licence:

visit [www.nationalarchives.gov.uk/doc/open-government-licence/](https://www.nationalarchives.gov.uk/doc/open-government-licence/),  
write to the **Information Policy Team, The National Archives, Kew, London TW9 4DU**,  
or email [psi@nationalarchives.gsi.gov.uk](mailto:psi@nationalarchives.gsi.gov.uk).

Highway Structures & Bridges  
Design

## CD 352 - NINAA

# Northern Ireland National Application Annex for Design of road tunnels

(formerly BD 78/99)

Version 0.0.1

### Summary

There are no specific requirements for the Department of Infrastructure, Northern Ireland, supplementary or alternative to those given in CD 352.

### Feedback and Enquiries

Users of this document are encouraged to raise any enquiries and/or provide feedback on the content and usage of this document to the dedicated team in the Department for Infrastructure, Northern Ireland. The email address for all enquiries and feedback is: [dcu@infrastructure-ni.gov.uk](mailto:dcu@infrastructure-ni.gov.uk)

**This is a controlled document.**

**Release notes**

**2**

## Latest release notes

Document code	Version number	Date of publication of relevant change	Changes made to	Type of change
CD 352 - NINAA	0.0.1	November 2024	Core document, England NAA	Incremental change to notes and editorial updates

No change this revision. Publication date November 2024: Department for Infrastructure Northern Ireland National Application Annex to CD 352.

## Previous versions

Document code	Version number	Date of publication of relevant change	Changes made to	Type of change
CD 352	0	March 2020		

© Crown copyright 2024.

You may re-use this information (not including logos) free of charge in any format or medium, under the terms of the Open Government Licence. To view this licence:

visit [www.nationalarchives.gov.uk/doc/open-government-licence/](https://www.nationalarchives.gov.uk/doc/open-government-licence/),  
write to the **Information Policy Team, The National Archives, Kew, London TW9 4DU**,  
or email [psi@nationalarchives.gsi.gov.uk](mailto:psi@nationalarchives.gsi.gov.uk).



Highway Structures & Bridges  
Design

## CD 352 - SNAA

# Scotland National Application Annex for Design of road tunnels

(formerly BD 78/99)

Version 0.0.1

### **Summary**

There are no specific requirements for Transport Scotland supplementary or alternative to those given in CD 352.

### **Feedback and Enquiries**

Users of this document are encouraged to raise any enquiries and/or provide feedback on the content and usage of this document to the dedicated Transport Scotland team. The email address for all enquiries and feedback is: [TSSStandardsBranch@transport.gov.scot](mailto:TSSStandardsBranch@transport.gov.scot)

**This is a controlled document.**

**Release notes**

**2**

## Latest release notes

Document code	Version number	Date of publication of relevant change	Changes made to	Type of change
CD 352 - SNAA	0.0.1	November 2024	Core document, England NAA	Incremental change to notes and editorial updates

Version 0.0.1: No change since last publication [Publication date November 2024]:Transport Scotland National Application Annex to CD 352.

## Previous versions

Document code	Version number	Date of publication of relevant change	Changes made to	Type of change
CD 352	0	March 2020		

© Crown copyright 2024.

You may re-use this information (not including logos) free of charge in any format or medium, under the terms of the Open Government Licence. To view this licence:

visit [www.nationalarchives.gov.uk/doc/open-government-licence/](https://www.nationalarchives.gov.uk/doc/open-government-licence/),  
write to the **Information Policy Team, The National Archives, Kew, London TW9 4DU**,  
or email [psi@nationalarchives.gsi.gov.uk](mailto:psi@nationalarchives.gsi.gov.uk).



Llywodraeth Cymru  
Welsh Government

Highway Structures & Bridges  
Design

## CD 352 - WNAA

# Wales National Application Annex for Design of road tunnels

(formerly BD 78/99)

Version 0.0.1

### **Summary**

There are no specific requirements for the Welsh Government supplementary or alternative to those given in CD 352.

### **Feedback and Enquiries**

Users of this document are encouraged to raise any enquiries and/or provide feedback on the content and usage of this document to the dedicated Welsh Government team. The email address for all enquiries and feedback is: [Standards\\_Feedback\\_and\\_Enquiries@gov.wales](mailto:Standards_Feedback_and_Enquiries@gov.wales)

**This is a controlled document.**

**Release notes**

**2**

## Latest release notes

Document code	Version number	Date of publication of relevant change	Changes made to	Type of change
CD 352 - WNAA	0.0.1	November 2024	Core document, England NAA	Incremental change to notes and editorial updates

Version 0.0.1: No change since last published. [Publication date November 2024. Welsh Government National Application Annex to CD 352.

## Previous versions

Document code	Version number	Date of publication of relevant change	Changes made to	Type of change
CD 352	0	March 2020		

© Crown copyright 2024.

You may re-use this information (not including logos) free of charge in any format or medium, under the terms of the Open Government Licence. To view this licence:

visit [www.nationalarchives.gov.uk/doc/open-government-licence/](https://www.nationalarchives.gov.uk/doc/open-government-licence/),  
write to the **Information Policy Team, The National Archives, Kew, London TW9 4DU**,  
or email [psi@nationalarchives.gsi.gov.uk](mailto:psi@nationalarchives.gsi.gov.uk).