**VOLUME 3 HIGHWAY STRUCTURES:
INSPECTION AND
MAINTENANCE**
SECTION 4 ASSESSMENT

PART 6

BA 39/93

**ASSESSMENT OF REINFORCED
CONCRETE HALF-JOINTS**

SUMMARY

This Advice Note provides guidance on the assessment of reinforced concrete half-joints in accordance with the requirements of BD 44 and BS 5400: Part 4: 1990 as implemented by BD 24.

INSTRUCTIONS FOR USE

This is a new document to be incorporated into the Manual.

1. Insert BA 39/93 into Volume 3 Section 4.
2. Archive this sheet as appropriate.

Note: New contents pages for Volume 3 containing reference to this document are available with BD 45/93.



THE DEPARTMENT OF TRANSPORT

BA 39/93



THE SCOTTISH OFFICE INDUSTRY DEPARTMENT



THE WELSH OFFICE
Y SWYDDFA GYMREIG



THE DEPARTMENT OF THE ENVIRONMENT FOR
NORTHERN IRELAND

Assessment of Reinforced Concrete Half-joints

Summary: This Advice Note contains guidance on the assessment of reinforced concrete half-joints in accordance with the requirements of BD 44 and BS 5400: Part 4: 1990 as implemented by BD 24.

Printed and Published by the
above Overseeing Departments
© Crown Copyright 1993

Price: £1.00

REGISTRATION OF AMENDMENTS

Amend No	Page No	Signature & Date of incorporation of amendments	Amend No	Page No	Signature & Date of incorporation of amendments

SUPERSEDED

Registration of Amendments

REGISTRATION OF AMENDMENTS

Amend No	Page No	Signature & Date of incorporation of amendments	Amend No	Page No	Signature & Date of incorporation of amendments

SUPERSEDED

VOLUME 3 HIGHWAY
STRUCTURES
INSPECTION AND
MAINTENANCE
SECTION 4 ASSESSMENT

PART 6

BA 39/93

**ASSESSMENT OF REINFORCED
CONCRETE HALF-JOINTS**

Contents

Chapter

1. Introduction
2. Serviceability Limit State
3. Ultimate Limit State
4. Reinforcement
5. References
6. Enquiries

Appendix A

Appendix B

1. INTRODUCTION

General

1.1 This Advice Note gives guidance on the assessment of concrete half-joints at both the ultimate and serviceability limit states. It is based on the findings of a recent research project⁽¹⁾ which investigated the behaviour of a range of half-joints, combining a variety of reinforcement layouts with different types of bearings.

1.2 The main problem in assessing the long term durability of half-joints is the difficulty in determining the relevant strains and crack widths. This Advice Note presents an elastic analysis for doing this which has been modified to allow for the non-linear behaviour in the region of the re-entrant corner. An explanation of the analysis is given in Appendix A together with a worked example of the method in Appendix B.

1.3 The arrangement and detailing of the reinforcement is an important factor in the performance of a half-joint. The present requirements given in BS 5400: Part 4: 1990⁽²⁾ (hereinafter referred to as Part 4) are mainly concerned with the ultimate limit state. As a result of the research by Clark⁽¹⁾ a need for additional reinforcement to ensure a satisfactory performance under service loading has been identified. When assessing an existing half-joint, it is therefore necessary to compare the reinforcement provided with the combined recommendations of the Advice Note and BD 44, the Assessment of Concrete Highway Bridges and Structures (DMRB 3.4).

1.4 Any reference in this Advice Note to a British Standard is to that Standard as implemented by the appropriate Departmental Standard.

Scope

1.5 The advice given in this document is applicable to both upper and lower reinforced concrete half-joints. It may also be applied to pre-tensioned and post-tensioned prestressed half-joints which for this purpose can be considered as reinforced concrete elements. For pre-tensioned members, the prestressing force and tendons should be ignored, but for post-tensioned members the prestressing force should be considered as an external force acting on the half-joint.

1.6 The behaviour of half-joints has been found to be influenced by the eccentricity of the reaction and the type of bearing. This Advice Note covers the use of both rigid and flexible bearings.

1.7 The criteria given in the Advice Note are intended to be used in conjunction with that given in BD 44 (DMRB 3.4). The Advice Note covers both serviceability and ultimate limit states.

Implementation

1.8 This Advice Note should be used in all future assessments of reinforced concrete half-joints. It should also be taken into account in assessments currently in hand unless, in the opinion of the Overseeing Department, this would result in unacceptable additional expense or delay.

2. SERVICEABILITY LIMIT STATE

General

2.1 Although assessments are normally carried out at the ultimate limit state, for half-joints, because of durability considerations, it is advisable to check the serviceability limit state in an assessment. The serviceability criteria stipulated in Part 4 for design should, in general, be adopted for the assessment of half-joints. However, the Technical Approval Authority may, under particular conditions of exposure, feel it necessary to modify the Part 4 requirements. Methods for determining strains and crack widths are given in this Advice Note.

2.2 Where the serviceability criteria are exceeded, inspection of the half-joint should be undertaken to confirm the condition of the joint. If there is no cracking and the load carrying capacity of the joint is adequate, more frequent future inspection may be the only course of action to be adopted. Where there is extensive cracking or spalling, it is unlikely to be practicable to strengthen the joint just to satisfy the serviceability criteria. Repair of damaged concrete and reinforcement may also prove difficult where access is restricted. Therefore it is important that such joints are regularly inspected to monitor their performance and measures are taken to prevent water reaching the repaired sections.

2.3 Tests on half-joints have shown that cracking is generally initiated at the re-entrant corner as a result of shrinkage, and that maximum crack widths subsequently occur at this point. The overall cracking pattern which develops is dependent on the reinforcement arrangement, the eccentricity of the reaction and the type of bearing. However, for half-joints which have been adequately designed for shear, it can be assumed for the purpose of analysis, that cracking will be concentrated in a zone which extends at 45° from the re-entrant corner towards the top of the section, as shown in Figure 2.1.

Strains

2.4 The strain distribution assumed in a half-joint at the serviceability limit state is illustrated in Figure 2.2. It can be seen that the maximum concrete tensile strain occurs at the re-entrant corner B and the maximum compressive strain ϵ_c occurs at the top surface of the member at A vertically above the line of intersection of the neutral axis with a line at 45° from the re-entrant corner. However the strain distribution in the tensile zone is non-linear and this leads to an under-estimate of the

tensile strain at the extreme fibre of the concrete at the re-entrant corner when using a linear elastic analysis. The non-linearity in the strain distribution is as a result of slip occurring between the reinforcement and the concrete. Therefore, whilst the compressive strain in the concrete and the tensile strain in the reinforcement can be determined directly from an elastic analysis, as shown in Appendix A, some modification of the extreme fibre concrete tensile strain is required. A factor K_1 , derived from the tests on half-joints, is applied to the strain at the re-entrant corner, ϵ_1 , determined by an elastic analysis, to give:

$$\epsilon' = K_1 \epsilon_1 \quad \dots (i)$$

where ϵ' is the modified re-entrant corner strain and K_1 is taken as 2.3 when inclined reinforcement is present and 3.5 where inclined bars are omitted.

In addition to slippage some allowance must be made for the tension stiffening effect in the cracked concrete section. The complete expression for ϵ' therefore becomes:

$$\epsilon' = K_1 \epsilon_1 - K_2 \frac{b h f_t}{E_s \epsilon_s A_s \gamma_m} \quad \dots (ii)$$

where

- K_2 is derived from test evidence and can be taken as 0.3×10^{-3}
- b is the breadth of the half-joint in mm.
- h is the depth of the half-joint in mm.
- f_t is the modulus of rupture of the concrete, taken as $0.556 \sqrt{f_{cu}}$, in N/mm².
- E_s is the elastic modulus of steel in N/mm².
- ϵ_s is the strain at the steel level in the direction normal to a 45° line from the re-entrant corner, determined from an elastic analysis. (See Figure 2.2).
- f_{cu} is the characteristic concrete cube strength, in N/mm².
- γ_m is the appropriate partial safety factor for material strength.
- A_s is the effective area of steel in mm² normal

to a 45° crack from the re-entrant corner, determined from:

$$A_s = \sum_{i=1}^{\eta} A_{s_i} \cos^2 (45 - \beta_i),$$

where A_{s_i} is the area of one layer of reinforcement at an angle β_i to the horizontal.

Crack Width

2.5 The predicted maximum crack width, w , at the re-entrant corner is taken as the lesser of the values from the following equations using the modified strain ϵ' from equation (ii):

$$w = \sqrt{2}(a - 0.5y)\epsilon' \quad \dots \text{(iii)}$$

and $w = 3a_{cr}\epsilon' \quad \dots \text{(iv)}$

- where
- a is the distance of the vertical reaction taken at the front edge of a rigid bearing or centre line of a flexible bearing from the re-entrant corner in mm.
 - y is the dimension of the fillet in mm.
 - a_{cr} is the distance from the nearest bar to the point where the crack width is calculated in mm.

Equation (iii) is based on the average strain over a distance of $\sqrt{2}(a - 0.5y)$ on either side of the crack, as illustrated in Figure 2.3. The crack width determined by this equation can become unrealistic for large values of a , since in such cases more than one crack will occur and the maximum crack width reduces. In these situations, the maximum crack width would be more accurately determined by assuming the element behaves as a long cantilever and using equation (iv) which is based on equation 26 of Part 4. For the purpose of this Advice Note, equation (iv) will govern when a is greater than $3a_{cr}/\sqrt{2} + 0.5y$. The predicted maximum crack width should be checked against the limit stipulated in Part 4.

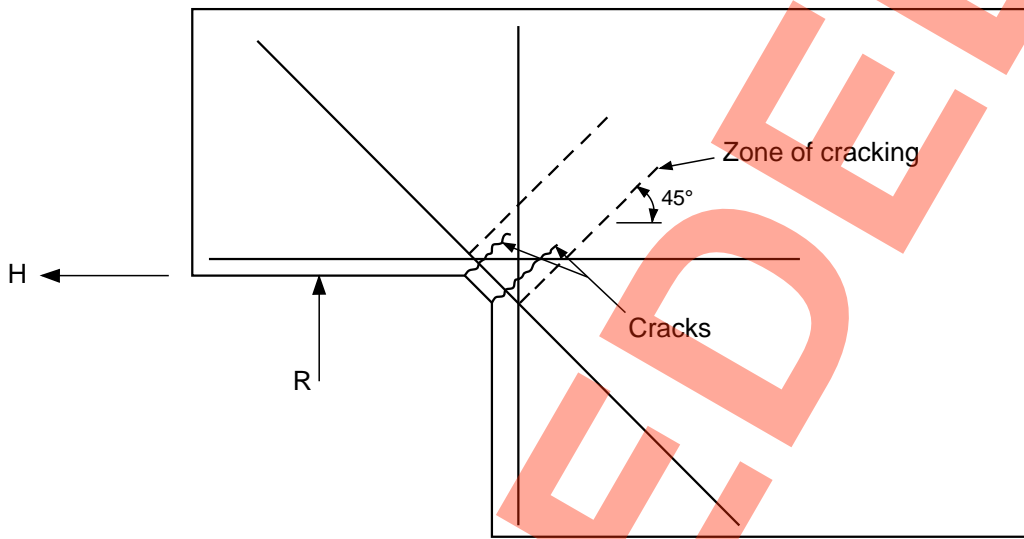

Figure 2.1 - Zone of cracking

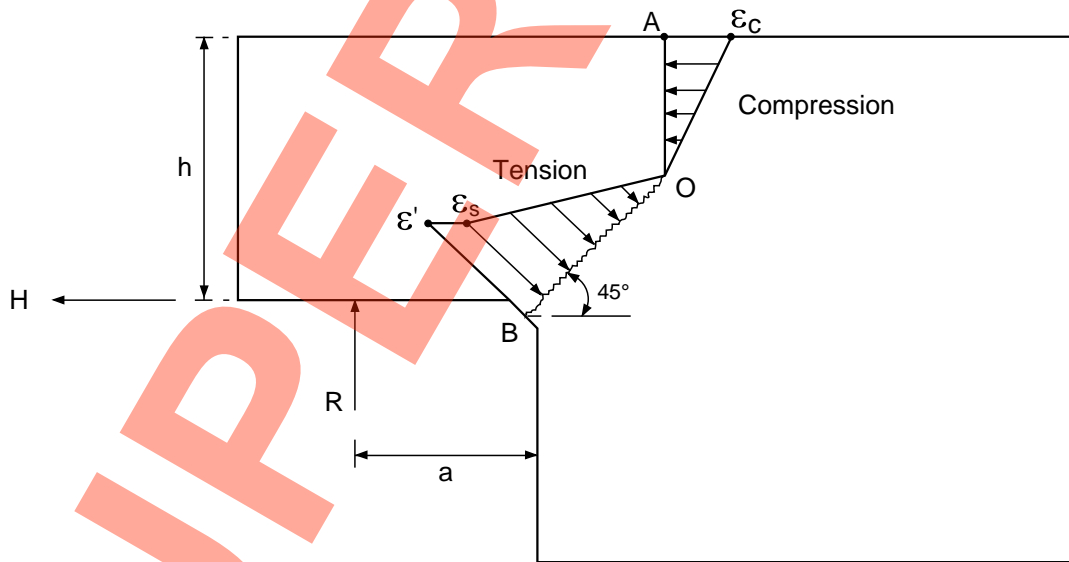

Figure 2.2 - Strain distribution

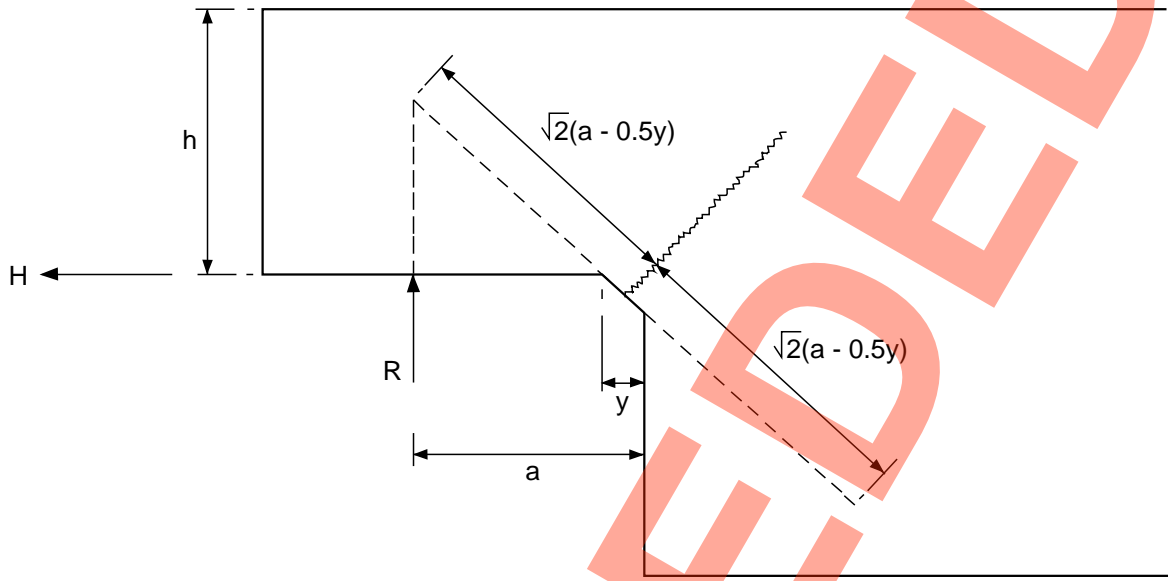

Figure 2.3 - Crack width model

3. ULTIMATE LIMIT STATE

General

3.1 The strength of a half-joint for assessment of existing structures should be determined in accordance with the requirements of BD 44 (DMRB 3.4).

- b is the effective width of the slab in mm, taken as the lesser of the spacing of the bearings in the transverse direction or the width of the bearing plus 2d.
- b_w is the width of the bearing in mm.

Horizontal Forces

3.2 When determining the horizontal forces to be resisted by the reduced section of a half-joint, as shown in Figure 7 of BD 44/90 (DMRB 3.4), consideration should be given to the additional horizontal forces that may occur at the bearing. Clause 7.2.3.4 of BD 44/90 (DMRB 3.4) lists some of the possible causes of these forces. If significant, such forces can reduce the load carrying capacity of the section by causing premature cracking over the bearing.

The lateral reinforcement within the length of the reduced depth section can be considered to contribute to resist T.

3.3 In the tests on half-joints where such cracks have occurred, the cause was mainly attributed to high rotation of the bearing resulting in a concentration of loading at one end. Extensive cracking was observed during tests on half-joints with soft rubber bearings. Therefore their use is not recommended for half-joints. It is important to check that the type of bearing used for half-joints is capable of accommodating the rotation at the support.

3.4 In assessing half-joints which do not contain sufficient reinforcement to resist these horizontal forces, a tensile strength of $0.566 \sqrt{f_{cu}}/\gamma_m$ for concrete may be assumed.

3.5 For wide slabs with a number of bearing positions across the deck, consideration should be given to the lateral load distribution. Figure 3.1 illustrates a strut and tie system representing the load distribution as viewed in elevation at the end of the slab. The lateral reinforcement in the non-loaded face can be assumed to be subject to a tensile force T where,

$$T = P (b - b_w)/4d$$

and P is the vertical reaction at each bearing at the ultimate limit state in kN.

d is the effective depth to the lateral reinforcement in mm.

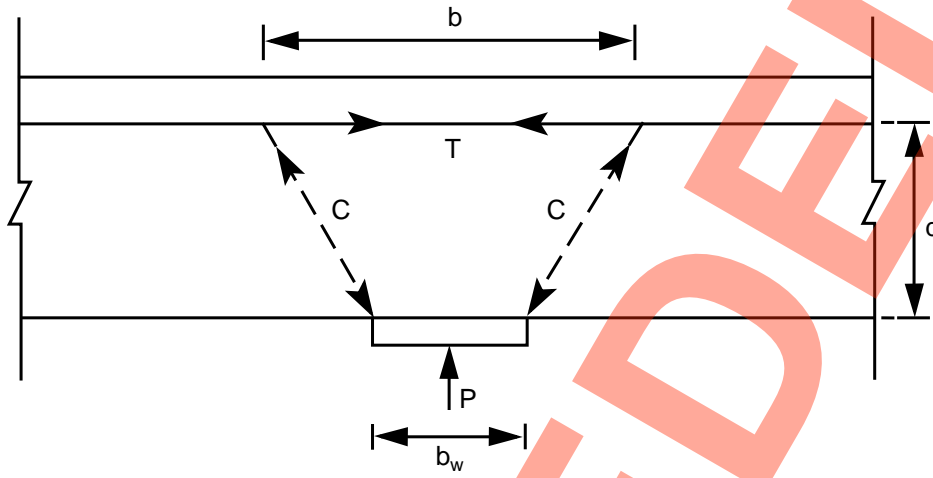

Figure 3.1 - Lateral load distribution

4. REINFORCEMENT

General

4.1 The arrangement of reinforcement in a half-joint contributes significantly to the behaviour of the element, particularly under service loads. Whilst certain combinations of horizontal, vertical and inclined bars will be satisfactory in ensuring an adequate ultimate load capacity, the resultant strains and crack widths under service loads may be unacceptable. It is therefore important to satisfy the necessary criteria for both serviceability and ultimate conditions to ensure the long term durability of these joints.

4.2 Where there is evidence of corrosion of reinforcement in a half-joint, allowance should be made for any loss of cross-section in assessing the strength of the element. In addition, consideration should be given to the effects due to corrosion on the fatigue life of the reinforcement and an assessment in accordance with BD 38 (DMRB 3.4) may be required.

Inclined Links

4.3 The presence of inclined links in a joint greatly improves the behaviour under service loading. Results from tests show that maximum crack widths are considerably greater for joints reinforced with only vertical links as compared to those reinforced with inclined links. Position of the link relative to the re-entrant corner also influences the crack width and links should therefore be positioned as accurately as possible. Strains and crack widths can be determined from the equations in paragraphs 2.4 and 2.5 of this Advice Note for all joints reinforced with inclined links, vertical links or a combination of the two.

Horizontal Reinforcement

4.4 Horizontal reinforcement in both top and bottom faces of the reduced section of a half-joint mitigate the effects of the concentrated load at the bearing and the effects of any applied loads. Horizontal bars provided at the bearing face of the joint help in resisting horizontal tensile stresses that may develop in the concrete at this position. The areas of reinforcement provided in a joint should be checked against the requirements of paragraphs 4.1 and 4.2 of this Advice Note. Ideally, a minimum area of secondary reinforcement in accordance with Clause

5.8.4.2 of BD 44/90 (DMRB 3.4) should be present. However, where this is not the case in an existing half-joint, regular inspection should be undertaken to monitor the development of any cracks.

Other Factors

4.5 Where half-joints are part of a pre-tensioned or post-tensioned member, the requirements for the provision of reinforcement in the transmission zone or end block should be determined in accordance with BD 44 (DMRB 3.4).

5. REFERENCES

1. Clark, L. A. and Thorogood, P. Serviceability Behaviour of Reinforced Concrete Half-Joints. TRRL Contractor Report 70, 1987.
2. BS 5400: Steel, Concrete and Composite Bridges: Part 4. Code of Practice for Design of Concrete Bridges. BSI, 1990. [*implemented by BD 24*]
3. Design Manual for Roads and Bridges
Volume 1: Section 3: General Design
BD 24 The Design of Concrete Highway Bridges and Structures. Use of BS 5400: Part 4: 1990 (DMRB 1.3.1)
Volume 3: Section 4: Assessment
BD 38 Assessment of the Fatigue Life of Corroded or Damaged Reinforcing Bars (DMRB 3.4.5)
BD 44 The Assessment of Concrete Highway Bridges and Structures (DMRB 3.4)

SUPERSEDED

6. ENQUIRIES

All technical enquiries or comments on this Advice Note should be sent in writing as appropriate to:-

Head of Bridges Engineering Division
The Department of Transport
St Christopher House
Southwark Street
London SE1 0TE

P H DAWE
Head of Bridges Engineering Division

The Deputy Chief Engineer
Roads Directorate
The Scottish Office Industry Department
New St Andrew's House
Edinburgh EH1 3TG

J INNES
Deputy Chief Engineer

Head of Roads Engineering (Construction) Division
Welsh Office
Y Swyddfa Gymreig
Government Buildings
Ty Glas Road
Llanishen
Cardiff CF4 5PL

B H HAWKER
Head of Roads Engineering
(Construction) Division

Superintending Engineer Works
Department of the Environment for
Northern Ireland
Commonwealth House
Castle Street
Belfast BT1 1GU

D O'HAGAN
Superintending Engineer Works

Orders for further copies should be addressed to:

DOE/DOT Publications Sales Unit
Government Building
Block 3, Spur 2
Lime Grove
Eastcote HA4 8SE

Telephone No: 081 429 5170

CALCULATION OF STRAINS BY ELASTIC ANALYSIS

Figure A.1 illustrates the elastic model from which ϵ_1 , the extreme fibre concrete tensile strain at the re-entrant corner, can be determined for any arrangement of reinforcement. It is assumed that under service loading, a half-joint of width b has a single 45° crack from the re-entrant corner extending to point O , above which the concrete is in compression. The principal strains are assumed to be either perpendicular to the crack or perpendicular to the line of principal compression, depending on the position in the section being considered, and are proportional to the distance from the point of zero strain, point O .

Figure A.2 shows the free body to the left of the crack and line of principal compression for the case of one layer of reinforcement with area A_{si} at an angle β_1 . If the extreme fibre compressive strain is ϵ_c then the strain perpendicular to the crack at the steel level is

$$\epsilon_i = \epsilon_c(d_i - x) \sqrt{2}/x \quad \dots(1)$$

where d_i = is the effective depth to the layer of reinforcement under consideration.
The strain in the direction of the steel, resolving strains in accordance with Mohr's circle is

$$\epsilon_{si} = \epsilon_i \cos^2(45 - \beta_1) \quad \dots (2a)$$

A better agreement with the test data is achieved by considering the strains as displacements and equation (2a) is re-written as

$$\epsilon_{si} = \epsilon_i \cos(45 - \beta_1) \quad \dots(2b)$$

The steel stress based on equation (2b) is

$$f_{si} = E_s \epsilon_{si} \quad \text{where } E_s \text{ is the elastic modulus of steel and the steel force is}$$

$$F_{si} = A_{si} f_{si}$$

Considering the forces acting on the free body, the horizontal component of one layer of reinforcement is

$$F_{hi} = F_{si} \cos \beta_1 = A_{si} E_s \epsilon_{si} \cos \beta_1$$

The concrete force C acting at a depth of $x/3$ is

$$C = E_c \epsilon_c b x / 2, \text{ where } E_c \text{ is the elastic modulus of concrete.}$$

Therefore for n layers of reinforcement as shown in Figure A3, horizontal equilibrium is given by

$$H + C - \sum_{i=1}^n F_{hi} = 0 \quad \dots (3)$$

and for moment equilibrium about O

$$R(a+h-x) + H(h-x) - C(2x/3) - \sum_{i=1}^n F_{si} \sqrt{2}(d_i - x) \cos(45 - \beta_1) = 0 \quad \dots (4)$$

Appendix A

where

- x is the depth to the neutral axis
- d_i is the depth of A_{si} at the position of the crack
- H is the horizontal reaction
- R is the vertical reaction

Equations (3) and (4) can be solved iteratively to give x and ϵ_c .

The steel strains can be determined from equation (2b) and the extreme fibre concrete tensile strain ϵ_t at the re-entrant corner obtained from:

$$\epsilon_t = \epsilon_c(h + 0.5y - x) \sqrt{2/x}$$

where y is the dimension of the fillet.

SUPERSEDED

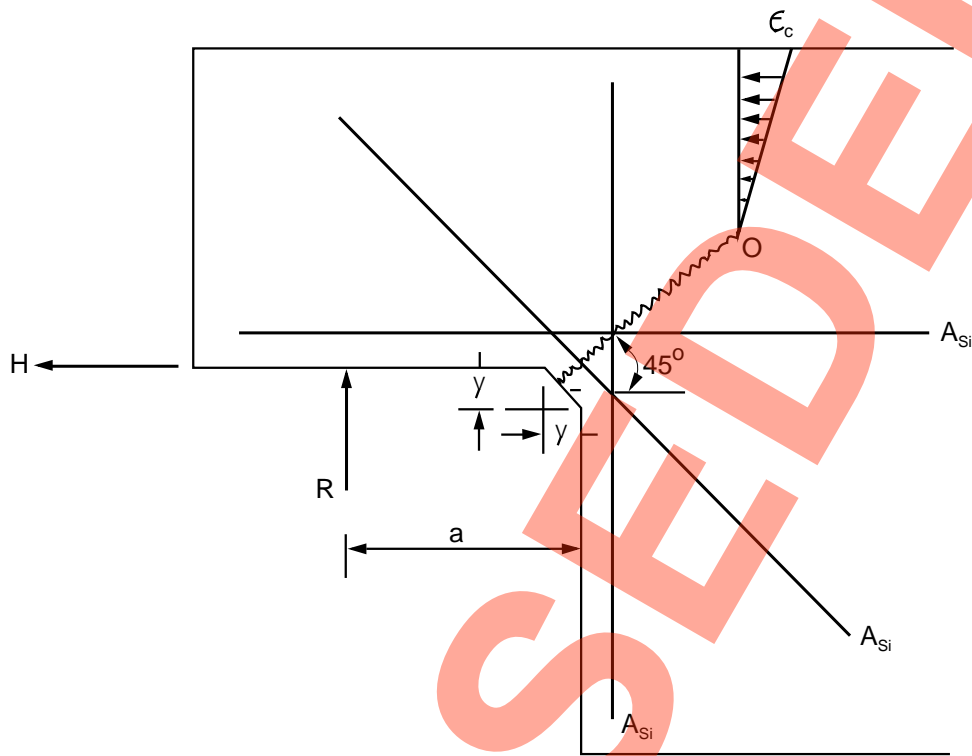

Figure A1

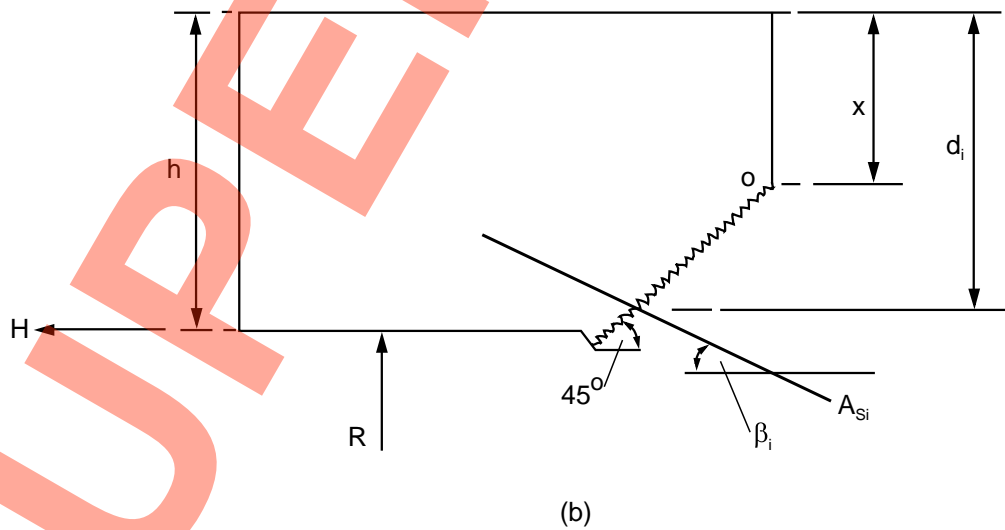

Figure A2

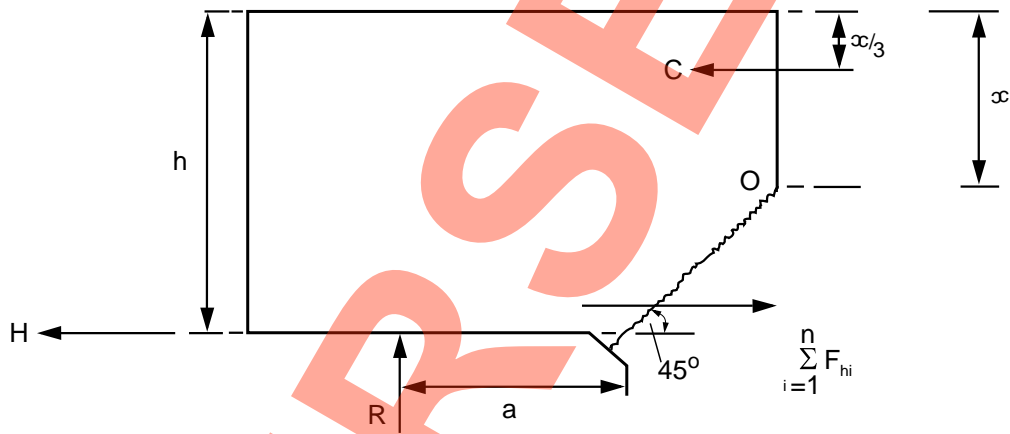

Figure A3

EXAMPLE OF CRACK WIDTH CALCULATION

Figure B1 shows the half-joint detail in a reinforced concrete voided slab which has been designed for 37.5 units of HB loading. The total width of the slab is 9.9m and the effective width of slab per bearing is taken as 1.1m. The main inclined reinforcement consists of T20 links in two layers giving an area per bearing in each layer of 2510mm². T12 U-bars and links provide the horizontal and vertical reinforcement respectively giving an area per bearing in each direction of 452mm².

a) Section Details

$$\begin{aligned}
 h &= 710\text{mm} & n &= 4 \\
 b &= 1100\text{mm} & l_i &= (d_i - x) \\
 a &= 305\text{mm} & \text{Cover} &= 35\text{mm} \\
 y &= 100\text{mm} \\
 A_{s1} &= 2510\text{mm}^2, \beta_1 = 60^\circ \\
 d_1 &= 710 + 50 - [(35+10)/\cos 15^\circ] \sin 45^\circ = 727\text{mm} \\
 A_{s2} &= 2510\text{mm}^2, \beta_2 = 60^\circ \\
 d_2 &= 760 - [(100+10)/\cos 15^\circ] \sin 45^\circ = 679\text{mm} \\
 A_{s3} &= 452\text{mm}^2, \beta_3 = 0^\circ, d_3 = 710 - 61 = 649\text{mm} \\
 A_{s4} &= 452\text{mm}^2, \beta_4 = 90^\circ, d_4 = 710 - 100 = 610\text{mm}
 \end{aligned}$$

$$A_s = \sum_{i=1}^4 A_{s_i} \cos^2 (45 - \beta_i) = 5136\text{mm}^2$$

b) Material Properties

$$\begin{aligned}
 f_{cu} &= 30\text{N/mm}^2 \\
 f_t &= 0.556 \sqrt{f_{cu}} = 3.05\text{N/mm}^2 \\
 E_c &= 28\text{kN/mm}^2 \\
 E_s &= 200\text{kN/mm}^2
 \end{aligned}$$

c) Loading

$$R = 1057\text{kN}, H = 0 \text{ (From Part 4 serviceability loading).}$$

d) Crack Width Analysis

Taking the equilibrium equations (3) and (4) in Appendix A, substitute for ΣF_{hi} and C in terms of A_{s_i} , ϵ_c , β_i , d_i and x. This gives

$$E_c \epsilon_c b x / 2 - \sum_{i=1}^4 (A_{s_i} E_s \epsilon_c (d_i - x) \sqrt{2} \cos(45 - \beta_i) \cos \beta_i) / x = 0 \tag{i}$$

and

$$R(a+h-x) - E_c \epsilon_c b x^2 / 3 - \sum_{i=1}^4 2 A_{s_i} E_s \epsilon_c (d_i - x)^2 \cos^2(45 - \beta_i) / x = 0 \tag{ii}$$

Evaluate $\sum_{i=1}^4 ()$ term from equation (i) for n = 4

$$\begin{aligned}
 \therefore \sum_{i=1}^4 () &= [343 \times 10^6 \epsilon_c (727 - x) + 343 \times 10^6 \epsilon_c (679 - x) \\
 &\quad + 90.4 \times 10^6 \epsilon_c (649 - x)] / x
 \end{aligned}$$

Appendix B

Substitute in equation (i) and find x

$$E_c \epsilon_c bx/2 - \epsilon_c \cdot 10^6 (54.09 x 10^4 - 776.4x)/x = 0$$

$$\therefore x = 164\text{mm}$$

Evaluate $\sum_{i=1}^4$ () term from equation (ii) and substitute

for x = 164mm

$$\therefore \sum_{i=1}^4 () = 356 \times 10^{10} \epsilon_c \text{ Substitute in equation (ii) and find } \epsilon_c$$

$$R(a + h - 164) - E_c \epsilon_c b 164^2/3 - 356 \times 10^{10} \epsilon_c = 0$$

$$\therefore \epsilon_c = 2.34 \times 10^{-4}$$

Determine the strain at the concrete surface ϵ_1 ,

where $\epsilon_1 = \epsilon_c (h + 0.5y - x) \sqrt{2} / x$

$$\epsilon_1 = 1.2 \times 10^{-3}$$

Determine the strain at the level of the outermost reinforcement layer, n = 1

where

$$\epsilon_{s1} = \epsilon_c (d_1 - x) \sqrt{2} \cos (45 - \beta_1) / x$$

$$\epsilon_{s1} = 1.09 \times 10^{-3}$$

Determine the modified value for strain at the concrete surface, where

$$\epsilon' = K_1 \epsilon_1 - K_2 bhf_t / E_s A_s \epsilon_s \gamma_m$$

and $K_1 = 2.3$ for inclined reinforcement

$$K_2 = 0.3 \times 10^{-3}$$

$$\gamma_m = 1.0$$

$$\therefore \epsilon' = 2.12 \times 10^{-3}$$

e) The crack width is determined from the lesser of

$$w_1 = \sqrt{2}(a - 0.5y)\epsilon' \quad \text{or} \quad w_2 = 3a_{cr}\epsilon'$$

For this example a_{cr} is based on the maximum spacing between the bars of 140mm, $a_{cr} = 73.2\text{mm}$. [$a_{cr} = \sqrt{(70^2 + (35+10)^2)} - 10 = 73.2\text{mm}$]

$$\therefore w_1 = 0.76\text{mm} \text{ or } w_2 = 0.47\text{mm}$$

Therefore the crack width is taken as 0.47mm. Permissible crack width from Table 1 of BS 5400; Part 4 is 0.25mm.

As the crack width exceeds the permissible value, inspection of the half-joint should be undertaken to confirm the condition of the joint.

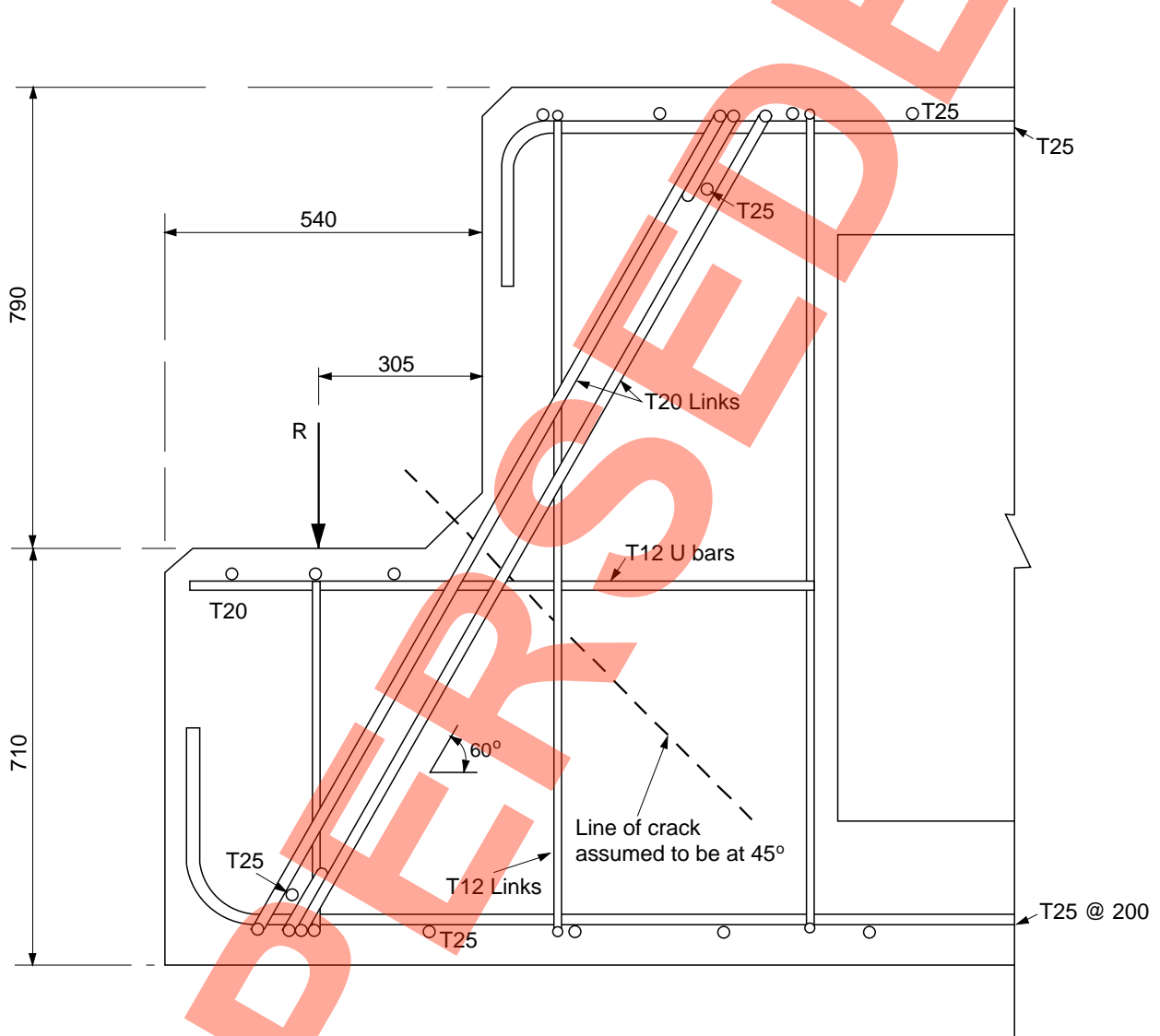

Figure B1 - Half joint in RC voided slab