**VOLUME 3 HIGHWAY STRUCTURES:
INSPECTION AND
MAINTENANCE**
SECTION 4 ASSESSMENT

PART 4

BA 16/97 AMENDMENT NO.2

**THE ASSESSMENT OF HIGHWAY
BRIDGES AND STRUCTURES**

SUMMARY

This Amendment includes revisions to incorporate changes in vehicle and axle loads following the introduction of the Road Vehicles (Authorised Weight) Regulations.

INSTRUCTIONS FOR USE

This amendment is to be incorporated in the Manual.

1. Remove existing contents page for Volume 6 and insert new contents page for Volume 6 dated November 2001.
2. Remove existing cover and contents sheet and insert new cover and contents sheet.
3. Insert the replacement pages listed on the Amendment Sheet (Amendment No 2), remove the corresponding existing pages, which are superseded by this and archive as appropriate.
4. Insert the Amendment Sheet at the front of the document after the new cover sheet.
5. Enter details of Amendment No 2 on Registration of Amendment sheet and sign and date to confirm the amendment has been incorporated.
6. Archive this sheet as appropriate.

Note: A quarterly Index with a full set of Volume Contents Pages is available separately from the Stationery Office Ltd.



THE HIGHWAYS AGENCY



SCOTTISH EXECUTIVE DEVELOPMENT DEPARTMENT



**THE NATIONAL ASSEMBLY FOR WALES
CYNULLIAD CENEDLAETHOL CYMRU**



**THE DEPARTMENT FOR REGIONAL DEVELOPMENT
NORTHERN IRELAND**

The Assessment of Highway Bridges and Structures

Summary: This Amendment includes revisions to incorporate changes in vehicle and axle loads following the introduction of the Road Vehicles (Authorised Weight) Regulations.

AMENDMENT NO 2 (NOVEMBER 2001)

Replacement Pages

Page number	Date
Chapter 2: 2/5, 2/6	November 2001
Chapter 3: 3/1, 3/2	November 2001
3: 3/5, 3/6	November 2001
3/9 – 3/12 incl.	November 2001
Chapter 4: 4/3, 4/4	November 2001
Chapter 7: 7/1, 7/2	November 2001
Chapter 10: 10/1, 10/2	November 2001
Chapter 11: 11/1, 11/2	November 2001
Annex A: A/1, A/2	November 2001
Annex B: B/1, B/2	November 2001

The replacement sheets supersede those dated May and November 1997. All superseded pages should be archived as appropriate.

REGISTRATION OF AMENDMENTS

Amend No	Page No	Signature & Date of incorporation of amendments	Amend No	Page No	Signature & Date of incorporation of amendments

SUPERSEDED

REGISTRATION OF AMENDMENTS

Amend No	Page No	Signature & Date of incorporation of amendments	Amend No	Page No	Signature & Date of incorporation of amendments

SUPERSEDED

**VOLUME 3 HIGHWAY STRUCTURES:
INSPECTION AND
MAINTENANCE**
SECTION 4 ASSESSMENT

PART 4

BA 16/97 AMENDMENT NO.2

**THE ASSESSMENT OF HIGHWAY
BRIDGES AND STRUCTURES**

Contents

Chapter

1. Introduction
 2. Simple Distribution Methods
 3. Assessment of Masonry Arch Bridges by the Modified MEXE Method
 4. Alternative Methods to the Modified MEXE Method
 5. Spandrel Walls and Dry-stone Walls
 6. Sub-structures, Foundations and Retaining Walls
 7. Jack Arch Bridges
 8. Metal Bridges
 9. Trough Deck Bridges
 10. References
 11. Enquiries
- Annex A - Derivation of Distribution Factors and Equivalent Axle Loads in Chapter 2
- Annex B - Effects of Multiple Axles on Arches
- Annex C - Maintenance and Repair
- Annex D - Defects in Arch Bridges
- Annex E - Comparison of Masonry Arch Bridge Assessment Methods
- Annex F - Example of Calculations for Determining the Load Capacity of a Masonry Arch Bridge
- Annex G - Studies on the Depth Factor and Condition Factor, Effects of Skew and Strength of Saddle Repaired Arches
- Annex H - The Assessment of Dry-stone Retaining Walls

1. INTRODUCTION

General

1.1 This Advice Note is intended to be used in conjunction with BD 21 (DMRB 3.4.3) for the assessment of highway bridges and structures. It covers certain types of structure or structural components where firm criteria cannot be given but where the assessment of structural adequacy involves the exercise of engineering judgement. It also contains details of alternative quick and simple methods of load distribution and arch assessment which, while being conservative, are nevertheless adequate for assessment purposes. Finally, it gives advice on ways of remedying the various defects which are found in different types of structure. Although this document is advisory in nature, the principles and methods given are acceptable to the Overseeing Organisation and may be deemed to satisfy any relevant criteria given in BD 21 (DMRB 3.4.3).

Scope

1.2 The field of application for this Advice Note is given in BD 21 (DMRB 3.4.3). In particular it provides a simple method of load distribution and an empirical method and a simple computerised method of arch assessment. It covers the assessment of structures which cannot be treated by normal calculation methods and the maintenance of the various different types of structure. Each of these items is discussed more fully in the following paragraphs.

Load Distribution

1.3 Graphs of load distribution factors are given for estimating the loads carried by internal and external girders of decks composed of longitudinal beams with certain specified forms of deck construction between them. The factors are only intended for use with the type of loading specified in BD 21 (DMRB 3.4.3) but can be used for determining both bending moments and shearing forces.

1.4 Equivalent axle loads are given to enable the direct determination of bending moments and shearing forces in internal and external girders of decks composed of transverse beams with certain specified forms of deck construction between them. The use of these simple methods is both quick and simple, and while they are believed to give conservative results, their use is recommended where applicable before more sophisticated and accurate methods are tried.

Modified MEXE Method of Arch Assessment

1.5 The modified MEXE method for arch assessment given in this document is a comprehensive method for determining the carrying capacity of single span brick and masonry arches in terms of allowable axle weights. The method as such is concerned solely with the strength of the arch barrel and takes account of the materials, various defects and geometric proportions which affect the strength of the arch. Factors are also given to take account of the effects of multiple axle bogies. The method is quick and simple to use and should be tried before more sophisticated methods of analysis are attempted.

Substructures, Foundations and Retaining Walls

1.6 Advice is given for qualitative assessment of dry-stone walls, retaining walls, spandrel walls of arches, sub-structures and foundations which cannot be assessed by mathematical means because of the number of unknown parameters involved and their complex behaviour. The advice draws the attention of the engineer to the various defects likely to be found in them and comments on their structural significance. However, ultimately a satisfactory assessment of such structures depends upon the correct interpretations of the physical observations and the exercise of engineering judgement supported by local knowledge.

Maintenance

1.7 Many structures which have been damaged or have deteriorated in various ways can be restored to their original load carrying capacity by carrying out fairly straightforward maintenance. Advice is given about the importance of the various defects and the remedial measures that can be taken to alleviate them. All types of structure within the scope of this Advice Note are considered for this purpose.

Definitions

1.8 For the purposes of this Advice Note the following definitions apply:

- (i) Load Distribution. The sharing of load between the main structural members as a consequence of the stiffness of intervening connecting members;

- (ii) Jack Arch. Concrete, brick or stone masonry arch spanning between the bottom flanges of two adjacent girders;
- (iii) Hogging Plate. Arched metal plating spanning between the bottom flanges of two adjacent girders;
- (iv) Bridge Axes:
 - The line joining the mid-points of the two unsupported edges of the bridge;
 - The axis through the mid-point of the first axis above and parallel to the unsupported edges of the bridge.

Note: Reference may also be made to the other definitions given in BD 21 (DMRB 3.4.3).

Symbols

1.9 The following symbols are used in this Advice Note:

A_f	Axle factor
A_p	Centrifugal distribution factor
d	Arch barrel thickness
F_A	Centrifugal effect factor
F_b	Barrel factor
F_{cM}	Condition factor for a MEXE assessment
F_d	Depth factor
F_f	Fill factor
F_j	Joint factor
F_m	Material factor
F_{mo}	Mortar factor
F_p	Profile factor
F_{sr}	Span/rise factor
F_w	Width factor
h	Depth of fill
K_L	Proportion factor for longitudinal girders
K_t	Proportion factor for KELs
L	Span of arch
M_E	Equivalent axle load for bending moment effect
PAL	Provisional axle loading
R	Bending moment or shear without centrifugal effects
R_c	Enhanced bending moment or shear
r_c	Rise of arch barrel at crown
r_q	Rise of arch barrel at quarter points
S_E	Equivalent axle load for shear force effect

S_k	KEL value
S_L	Shear on longitudinal member
S_U	Gross shear due to one lane of UDL

Implementation

1.10 This Advice Note should be used forthwith for assessments of load carrying capacity of trunk road bridges and other structures, including those structures currently being assessed, provided that, in the opinion of the Overseeing Organisation, this would not result in significant additional expense or delay progress. Its application to particular assessments should be confirmed with the Overseeing Organisation.

1.11 When a reduction in live loading in accordance with BD 21 (DMRB 3.4.3) has been used for an assessment and the bridge found adequate, the Maintaining Agent for the Overseeing Organisation must ensure that the surface characteristics and traffic flows relevant to the reduced loading are maintained. Otherwise, the structure must be re-assessed.

2. SIMPLE DISTRIBUTION METHODS

General

2.1 This chapter contains simple methods which can be used to determine the proportion of the loading carried by individual girders in decks which contain either longitudinal or transverse members spanning parallel between abutments. The methods can also be applied to transverse girders spanning between parapet girders. They do not, however, apply to the supporting parapet girders for which separate calculations must be made. Their use is limited to simply supported spans with the deck of the type specified in 2.2. A method is given for calculating the enhancement in the girder bending moments and shears, caused by centrifugal action, which takes into account the distribution of this effect.

The background to the derivation of the distribution factors and equivalent axle loads is given in Annex A.

The simple distribution methods are suitable for initial assessment of structures. In cases where the structure is found to be inadequate using the simple distribution methods, more detailed analysis such as a grillage or finite element analysis should be carried out using the loading requirements of BD 21 (DMRB 3.4.3).

Limitations

2.2 The methods described can only be used when the deck between the girders consists of any of the following:

- (i) reinforced concrete slab spanning over longitudinal or transverse beams;
- (ii) jack arches;
- (iii) hogging plates or cast iron floor plates supported on the bottom flanges of the members and carrying well compacted in-fill.

2.3 The methods cannot be used for any of the following types of construction:

- (i) where internal longitudinal girders (ie girders other than external parapet girders) support cross girders;
- (ii) where a member has simply supported deck plates or slabs resting on the top flange;
- (iii) where members span between abutments and the direction of the carriageway is at an angle greater than 10° and less than 80° to the axes of the bridge (see Figure 2/1).

2.4 In the cases where the methods cannot be used, the loading given in BD 21 (DMRB 3.4.3) can be distributed between members by simple statics.

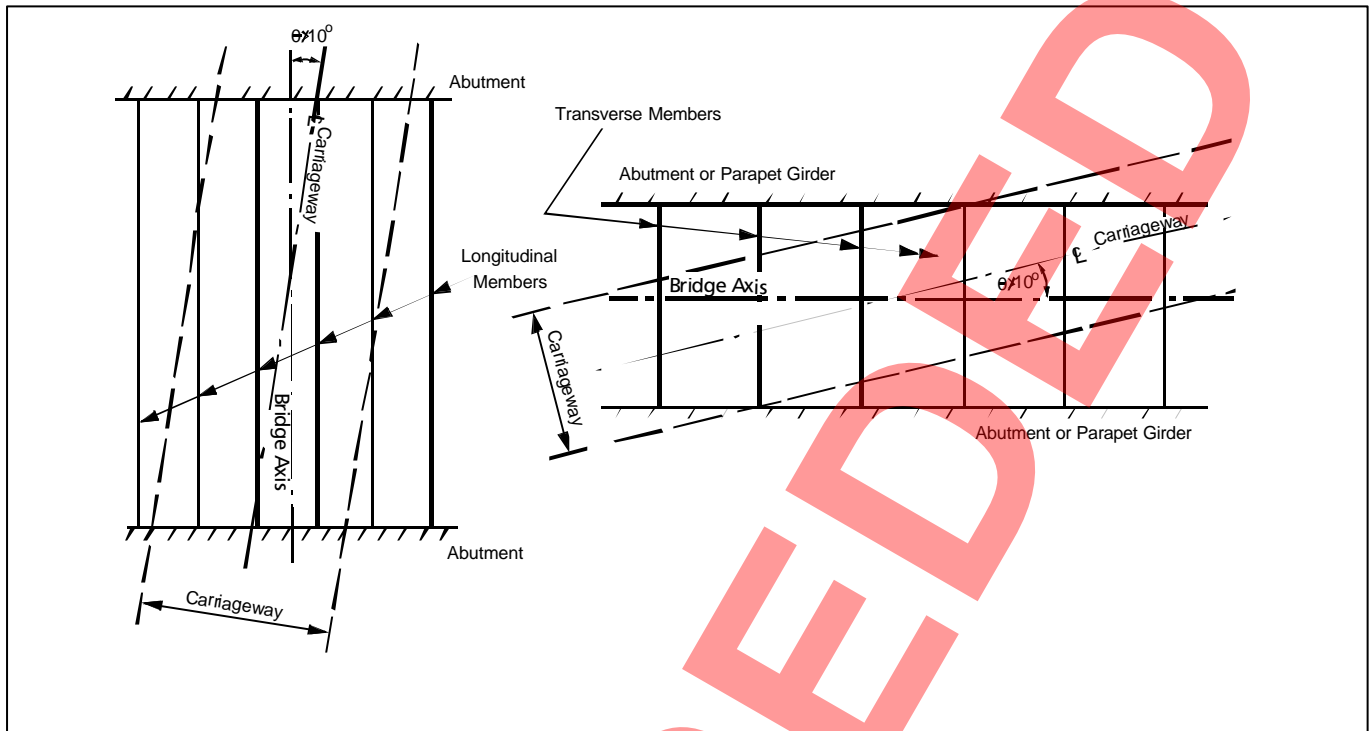

Figure 2/1 Carriageway Inclined to the Bridge Axes

Longitudinal Members - Bending Moments

2.5 Load proportion factors for longitudinal girders are given in Figures 2/2 and 2/3 for internal and external girders respectively. The figures cover the cases of single and multiple lane loading; the particular case to be considered will be governed by the lane width criteria given in BD 21 (DMRB 3.4.3).

2.6 The nominal live load bending moment applied to an internal girder under a traffic lane can be obtained by multiplying the gross moment due to the effects of the live load from one notional lane of width 2.5m as specified in BD 21 (DMRB 3.4.3) by the appropriate factor from Figure 2/2. If the angle of skew is greater than 35° an additional factor of 1.15 should be applied.

2.7 The bending moment applied to edge girders can be obtained in a similar way but using the appropriate factor from Figure 2/3. For right spans, if there is at least one structural member between the nearside wheels and the edge member then the latter need not be examined for live load on the carriageway.

Longitudinal Members - Shear

2.8 The nominal shear on a longitudinal member which is equal to or longer than 2m may be determined from the following expression:

$$S_L = K_L \cdot S_U + 0.5S_k$$

where S_L = shear on longitudinal member (kN)

K_L = appropriate proportion factor from Figures 2/2 or 2/3

S_U = gross shear of one 2.5m notional lane of UDL as specified in BD 21 (DMRB 3.4.3) (kN)

S_k = value of KEL for one 2.5m notional lane as specified in BD 21 (DMRB 3.4.3) (kN)

When the member span is less than 2m the shear should be calculated assuming static distribution and using the loading specified in BD 21 (DMRB 3.4.3).

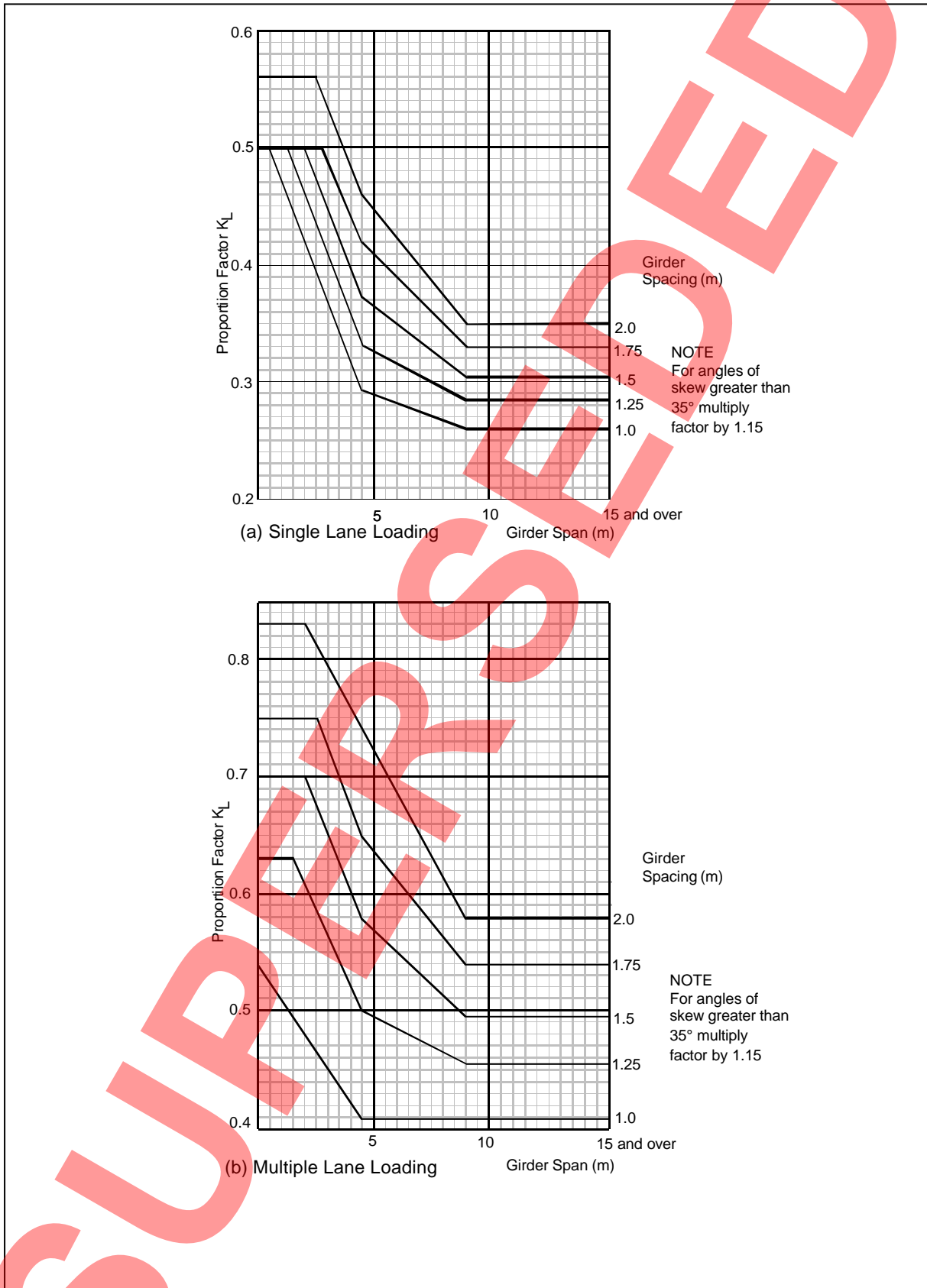
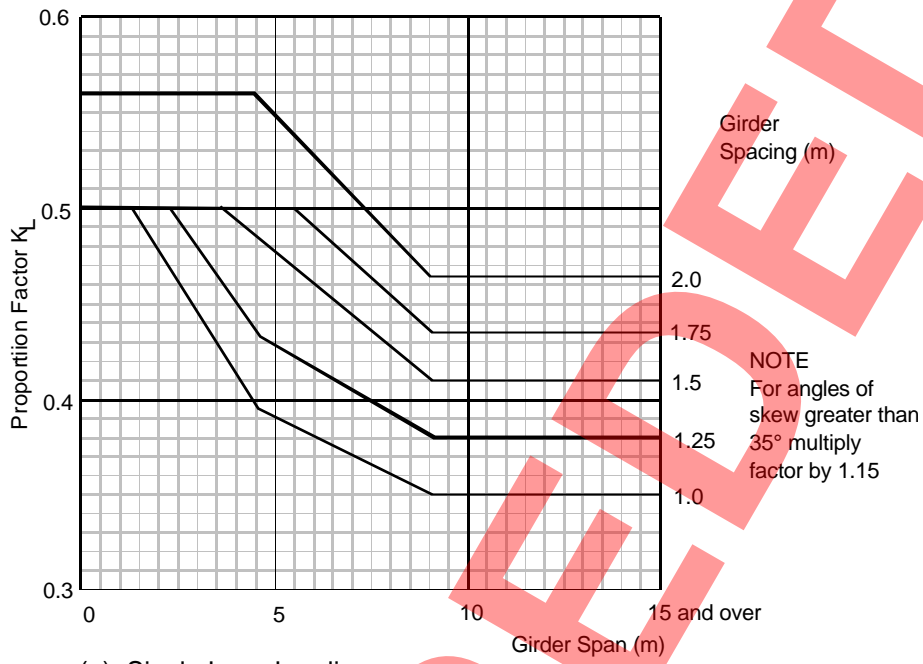
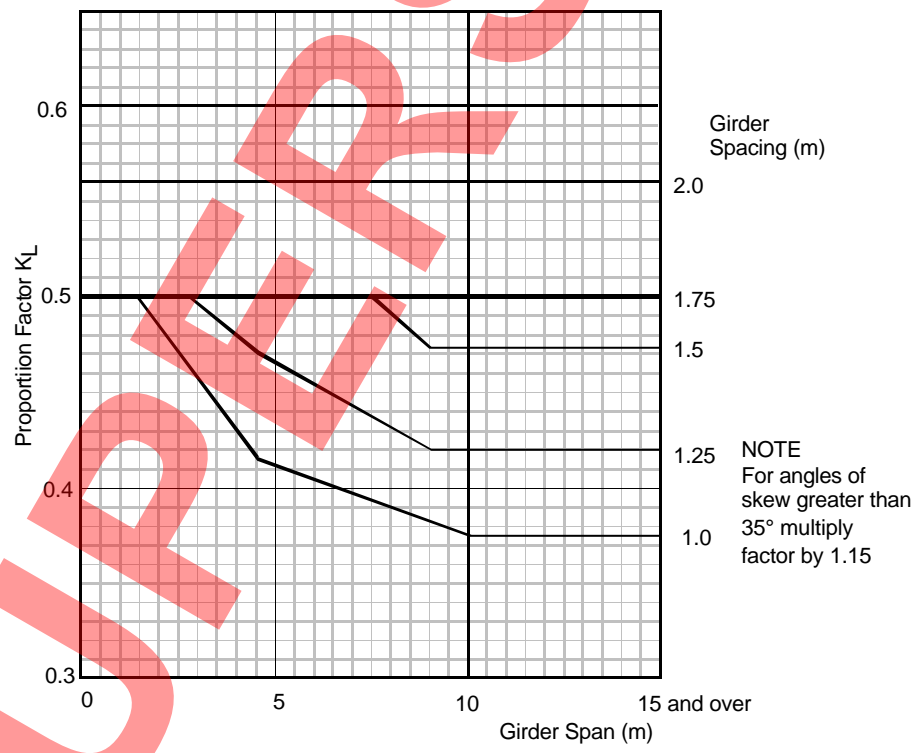

Figure 2/2 Proportion Factors for Internal Longitudinal Girders



(a) Single Lane Loading



(b) Multiple Lane Loading

Figure 2/3 Proportion Factors for External Longitudinal Girders

Transverse Members - Bending Moments and Shears

2.9 The nominal bending moments and shears induced in transverse girders can be determined for both internal and external girders by using the values of equivalent axle loads given in Figures 2/4 and 2/5 and Table 2/1. The steps in the calculation are as follows:

- (i) obtain an equivalent axle value M_E for a bending moment effect from Figure 2/4 (for an internal girder) or Figure 2/5 (for an external girder);
- (ii) obtain an equivalent axle load value S_E for a shear force effect from Table 2/1;
- (iii) convert M_E or S_E to two equal point loads 1.8m apart;
- (iv) position the point loads on the girder, irrespective of any lane markings, to give the worst bending moment or shear force effect;
- (v) calculate the nominal bending moments or shear forces.

2.10 For the purpose of 2.9 - 2.14 the carriageway shall be divided into 2.5m wide lanes, which shall be located at positions causing the most adverse loading effects. The equivalent axle loads are to be positioned within the lanes to cause the most onerous loading effect but there shall be at least 0.7m between the wheels of adjacent axles. If the carriageway is less than 5m wide only one equivalent axle load shall be used.

2.11 The equivalent axle load values (bending moment and shear) obtained from 2.9(i) shall only be used for up to two axles. The equivalent loads for any remaining axles shall be obtained by multiplying the values from 2.9(i) by 0.6.

2.12 In addition to the equivalent axle loads a UDL will be applied to any fractional part of a lane which remains after the carriageway has been divided into 2.5m widths. The value of the UDL in kN/metre should be $5\text{kN/m}^2 \times$ (sum of half the distance in metres between the adjacent cross girders). Figure 2/6 indicates the position of the loads to be considered.

2.13 The values of equivalent axle load for the transverse girder located next to an external girder are to be calculated by averaging the values obtained for internal and external girders.

2.14 The results provide values for the effects of 40 tonnes Assessment Live Loading. The effects of other levels of Assessment Live Loading can be estimated directly by multiplying these results by the appropriate Reduction Factors from Table 2/2.

Centrifugal Effects

2.15 The enhancement due to centrifugal effects of bending moments and shears, which have previously been determined from 2.5 to 2.14 may be calculated by means of the following expression:

$$R_c = R.A_p.F_A$$

Where R_c = enhanced bending moment or shear

R = bending moment or shear without centrifugal effects

A_p = distribution factor given in Table 2/3

F_A = factor given in BD 21 (DMRB 3.4.3)

Girder Spacing	Equivalent axle loads for the shear force effect kN	
	Internal Girder	External Girder
2.0	200	200
1.5	180	192
1.0	160	184

Table 2/1 Equivalent Axle Loads for the Shear Force Effect

Assessment Live Loading Level	Reduction Factors	
	Bending Effect	Shear Effect
26 tonnes	1.00	1.00
18 tonnes	1.00	1.00
7.5 tonnes	0.49	0.52
3 tonnes	0.17	0.17
Fire Engines Group 1	0.58	0.62
Fire Engines Group 2	0.29	0.31

Table 2/2 Reduction Factors for Assessment Live Loadings

Span	A_p	
	Longitudinal Member Edge Girders Only	Transverse Member Supported by Parapet Girders
Up to and including 6m	1.0	0.9
Over 6m and up to and including 9m	0.9	Centrifugal effect may be neglected
Over 9m and up to and including 12m	0.8	
Over 12m and up to and including 15m	0.7	

Table 2/3 Centrifugal Distribution Factor A_p

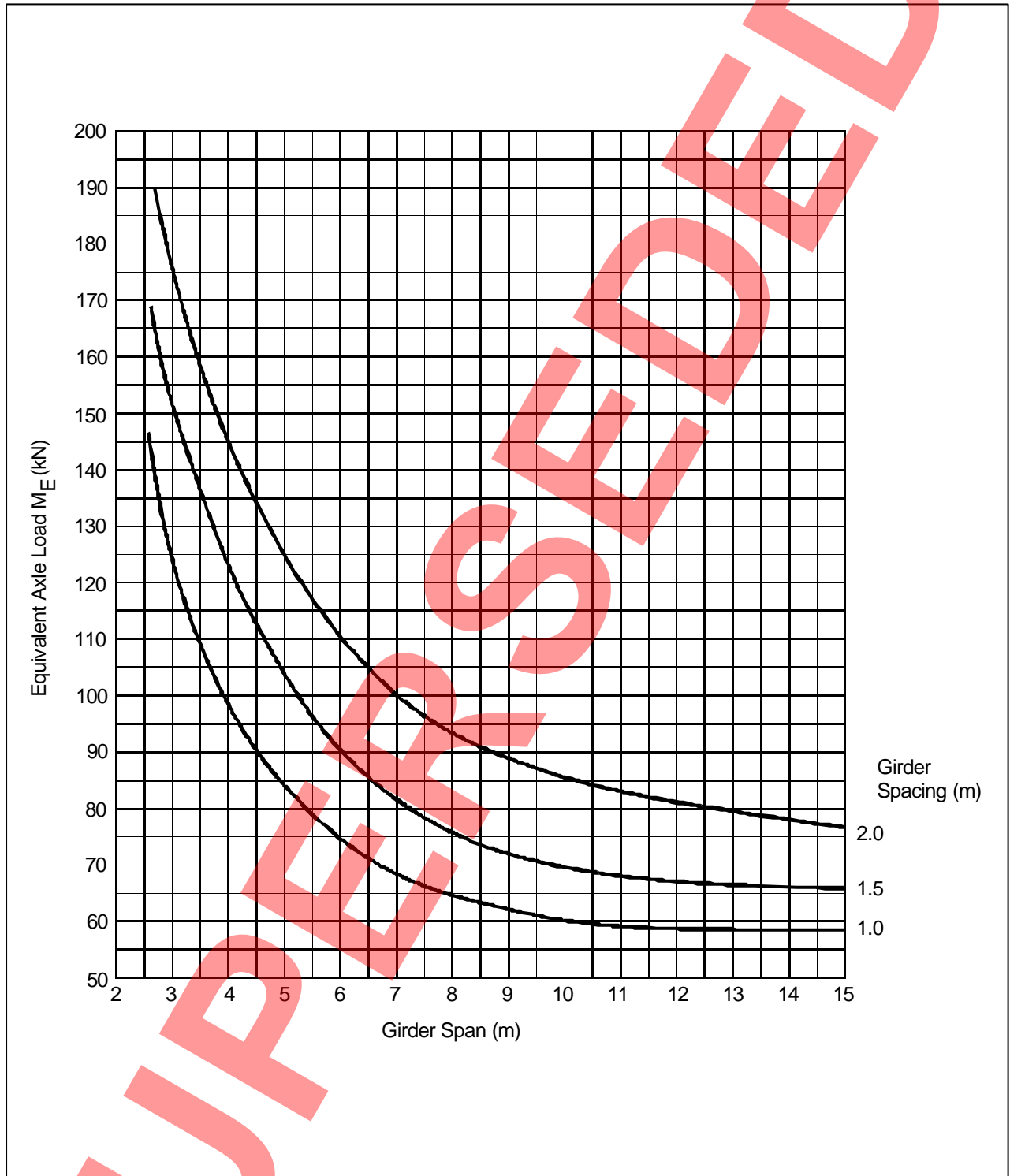

Figure 2/4 Bending Moment Effect for Transverse Girders
Equivalent Axle Loads for Internal Girders

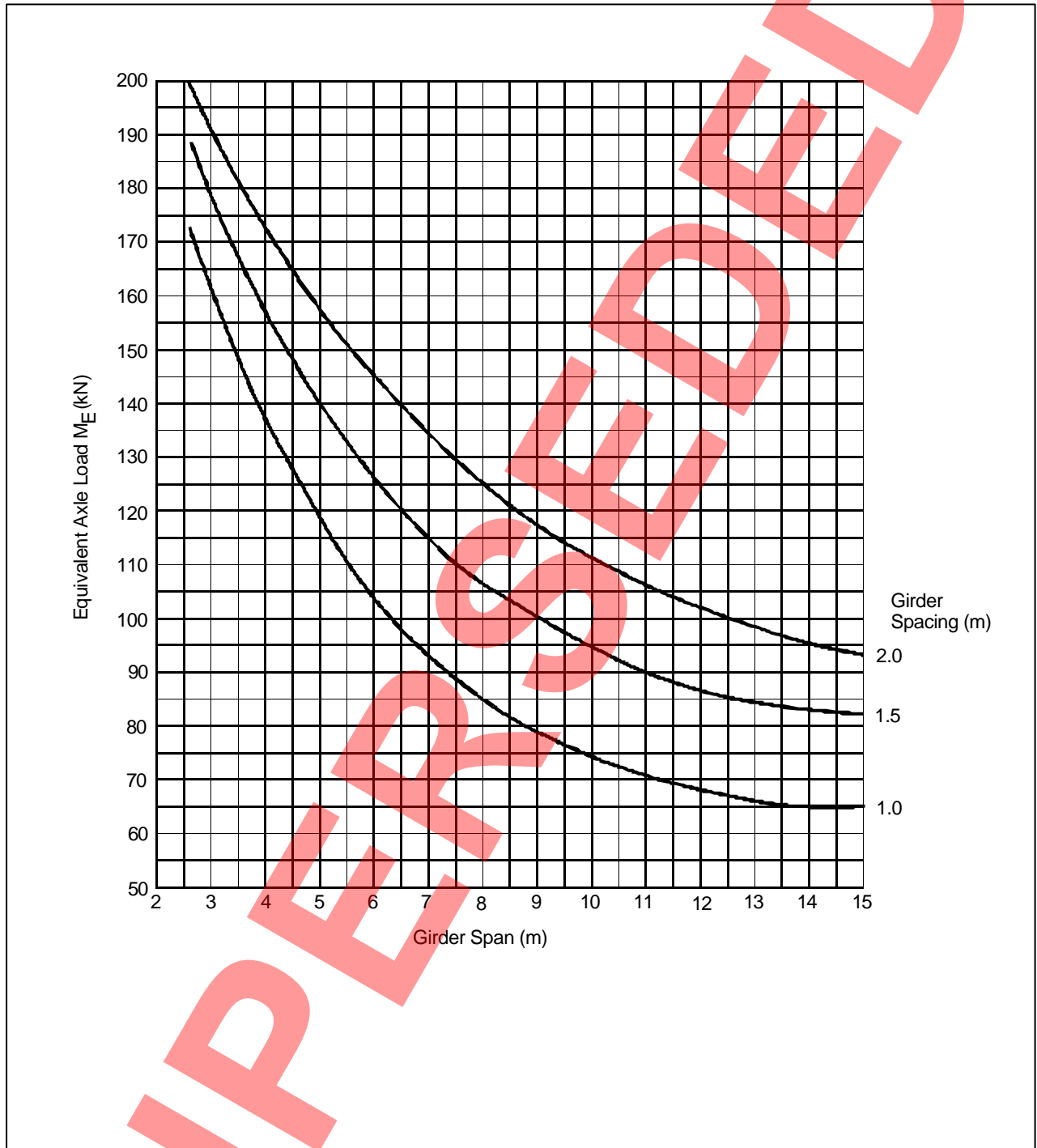

Figure 2/5 Bending Moment Effect for Transverse Girders
Equivalent Axle Loads for External Girders

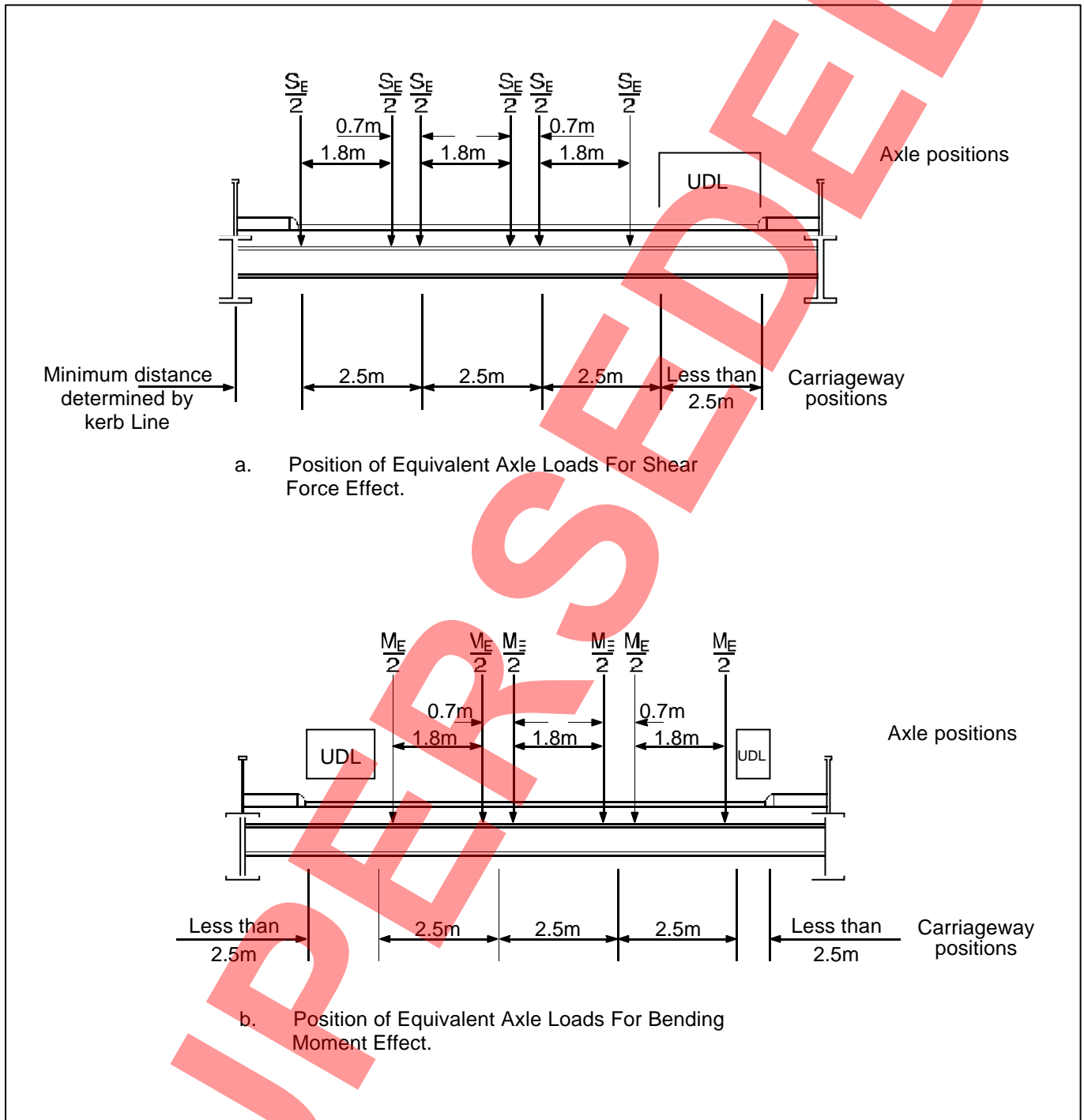

Figure 2/6 Application of Loads on Transverse Girders

[Note: A maximum of 2 lanes are to be loaded fully. The remaining lanes are to be loaded with 0.6 times the loadings shown above.]

3. ASSESSMENT OF MASONRY ARCH BRIDGES BY THE MODIFIED MEXE METHOD

Scope

3.1 This chapter deals with the assessment of the strength of the ARCH BARREL ONLY. The strength of the bridge may be affected by the strength of the spandrel walls, wing walls, foundations, etc. These items are dealt with under Chapter 8 of BD 21 (DMRB 3.4.3) and Chapters 5 and 6 of this Advice Note. The modified MEXE may be used to estimate the carrying capacity of arches spanning up to 18m, but for spans over 12m it becomes increasingly conservative compared to other methods. The method should not be used where the arch is flat or appreciably deformed.

Method of Assessment

3.2 The assessment of the arch barrel has been adapted from the method set out in "Military Load Classification (of Civil Bridges) by the Reconnaissance and Correlation Methods", MEXE May 1963 (10.2.1). This method is based on the results of past experience, and it has been found to give satisfactory results to date for the range of vehicles conforming to the Road Vehicles (Authorised Weight) Regulations (see BD 21 (DMRB 3.4.3)); but its extrapolated use for heavier vehicles, or for spans greater than 18m should be treated with caution. It is intended to be applied primarily to single span arches.

3.3 The initial assessment is in terms of a maximum allowable axle load on an axle forming part of a double axled bogie; factors are given in 3.25 for converting this result to other axle configurations and for situations where axle 'lift-off' may occur on the axle of a multiple axle bogie.

Theory

3.4 The long term strength of a brick or masonry arch is almost impossible to calculate accurately and recourse has, therefore, been made to an empirical formula based on the arch dimensions. The arch is first assumed to be parabolic in shape with span/rise ratio of 4, soundly built in good quality brickwork/stonework, with well pointed joints, to be free from cracks, and to have adequate abutments. For such an idealised arch, a provisional assessment is obtained from a nomogram (Figure 3/1) or from the formula given in 3.10. This provisional assessment is then modified by factors

which allow for the way in which the actual arch differs from the ideal.

Survey of Arch

3.5 The arch should be inspected in accordance with Chapter 2 of BD 21 (DMRB 3.4.3) and the following dimensions measured as shown in Figure 3/2:

- (i) The span L (m)
(in the case of skew spans, measure L parallel to the axis of the arch)
- (ii) The rise of the arch barrel at the crown r_c (m)
- (iii) The rise of the arch barrel at the quarter points r_q (m)
- (iv) The thickness of the arch barrel adjacent to the keystone (see 3.7) d (m)
- (v) The average depth of fill, at the quarter points of the transverse road profile, between the road surface and the arch barrel at the crown, including road surfacing h (m)

3.6 The following information will also be required to derive the various modifying factors:

Type of material used for the arch barrel
Type of construction of the barrel, ie are the voussoirs in courses or laid at random?
Condition of materials in the barrel, ie is there a lot of spalling and are the voussoirs sound or are they deteriorating due to weathering?
Deformation of the arch barrel from its original shape:

- Positions of dropped voussoirs and the amount of drop
- Width, length, number and positions of cracks
- Type of filling above the arch and its condition
- Position and size of services
- Width of mortar joints
- Depth of mortar missing from joints
- Condition of joint mortar

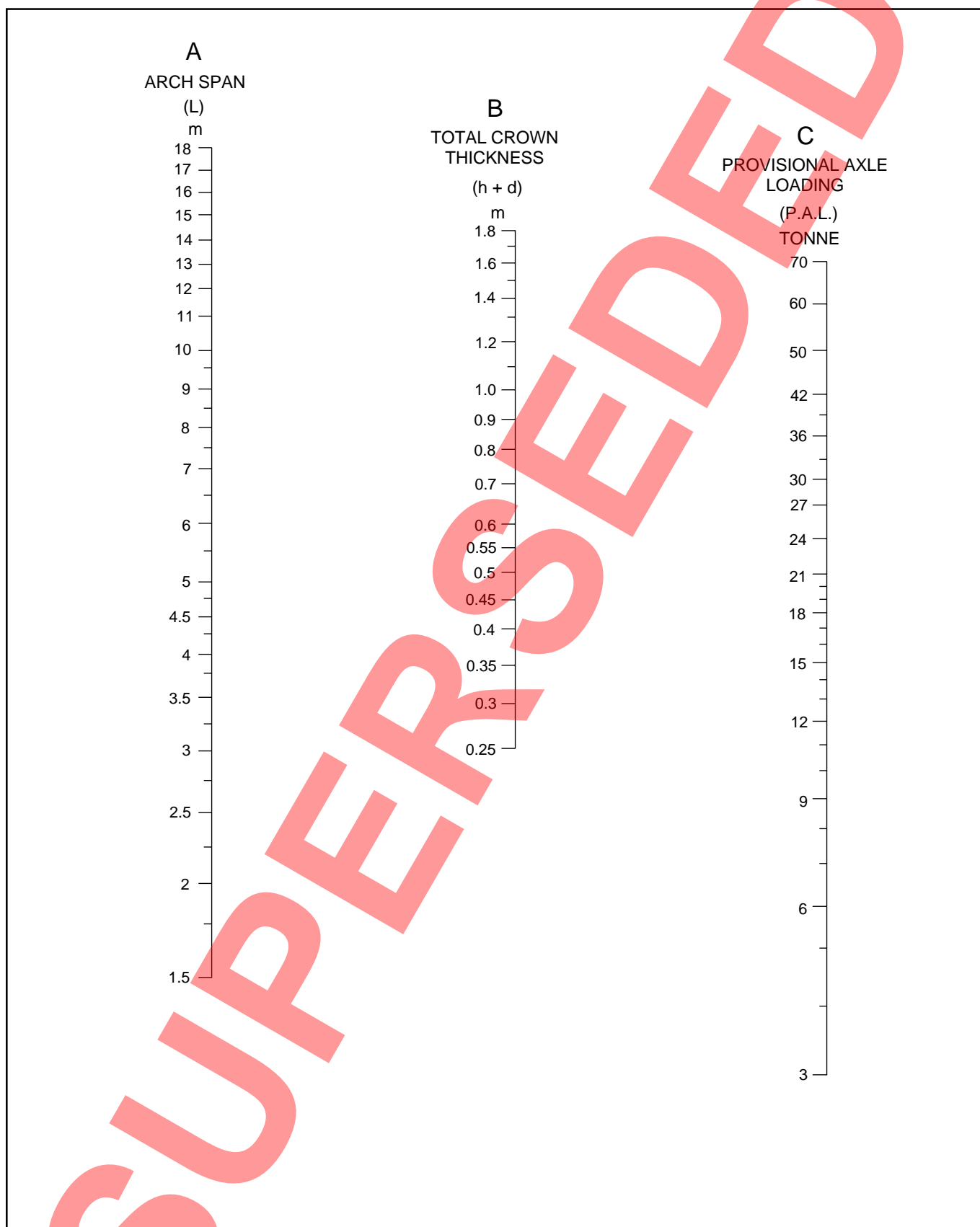

Figure 3/1 Nomogram for Determining the Provisional Axle Loading of Masonry Arch Bridges before Factoring

3.7 The appropriate measurements should be taken so that the arch barrel thickness may be adjusted to allow for missing mortar (see Table 3/5) and to allow for any services laid through the arch barrel.

3.8 Radial displacement of individual stones or bricks, especially near the crown when there is little cover, should be particularly noted (see Annex D plate 8). Displacement may be due to uneven masonry projecting above the barrel and being subjected to concentrated loads or a hard spot such as a pipe flange bearing directly on the arch. The damage is usually localised and not serious if dealt with before it has progressed too far. If, however, there are a number of voussoirs displaced, then this should be taken into account and the thickness of the arch barrel adjusted accordingly.

3.9 Note should be taken of any evidence of separation of the arch rings, particularly with regard to any additional rings which have been constructed in later years, and due account should be taken in the value assumed for the arch barrel thickness.

Provisional Assessment

3.10 The provisional axle loading *PAL* is obtained by reference to the nomogram in Figure 3/1. Mark the arch span *L* on Col A and the total crown thickness (*d + h*) (barrel and fill) on Col B. Line through these points to Col C, and read off the provisional axle loading assessment in tonnes. Alternatively, the provisional axle loading may be obtained by substituting the values of (*d + h*) and *L* in the following expression:

$$PAL = \frac{740(d+h)^2}{L^{1.3}} \quad \text{or } 70, \text{ whichever is less}$$

This expression has been derived from the nomogram and should only be used within the limits given in Figure 3/1.

The provisional axle load obtained is then modified by the modifying factors in 3.11 to 3.16 and the condition factor in 3.17 to 3.24.

Modifying Factors

3.11 Span/Rise Factor (F_{sr}). Flat arches are not so strong under a given loading as those of steeper profile, and the provisional assessment must, therefore, be adjusted. A span/rise ratio of 4 and less is assumed to give optimum strength and has a factor of 1. When the span/rise ratio is greater than 4, reference should be made to the graph in Figure 3/3 which gives the appropriate span/rise factor F_{sr} for the different ratios.

3.12 Profile Factor (F_p). There is evidence that elliptical arches are not so strong as segmental and parabolic arches of similar span/rise ratio and barrel thickness. The ideal profile has been taken to be parabolic and for this shape the rise at the quarter points, $r_q = 0.75r_c$, where r_c is the rise at the crown.

The profile factor F_p for ratios of r_q/r_c less than or equal to 0.75 should be taken to be unity, and for ratios greater than 0.75 should be calculated from the expression:

$$F_p = 2.3 \left[\frac{r_c - r_q}{r_c} \right]^{0.6}$$

For convenience this has been plotted in Figure 3/4.

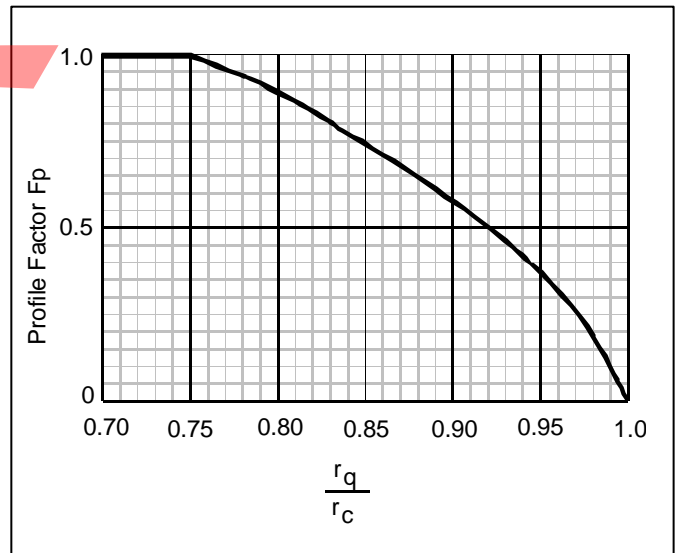

Figure 3/4 Profile Factor

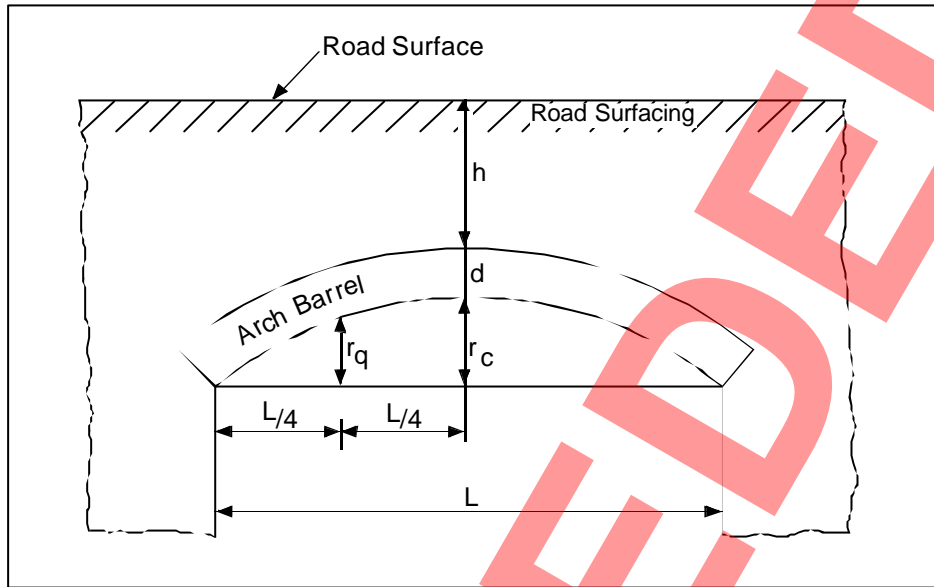

Figure 3/2 Arch Dimensions

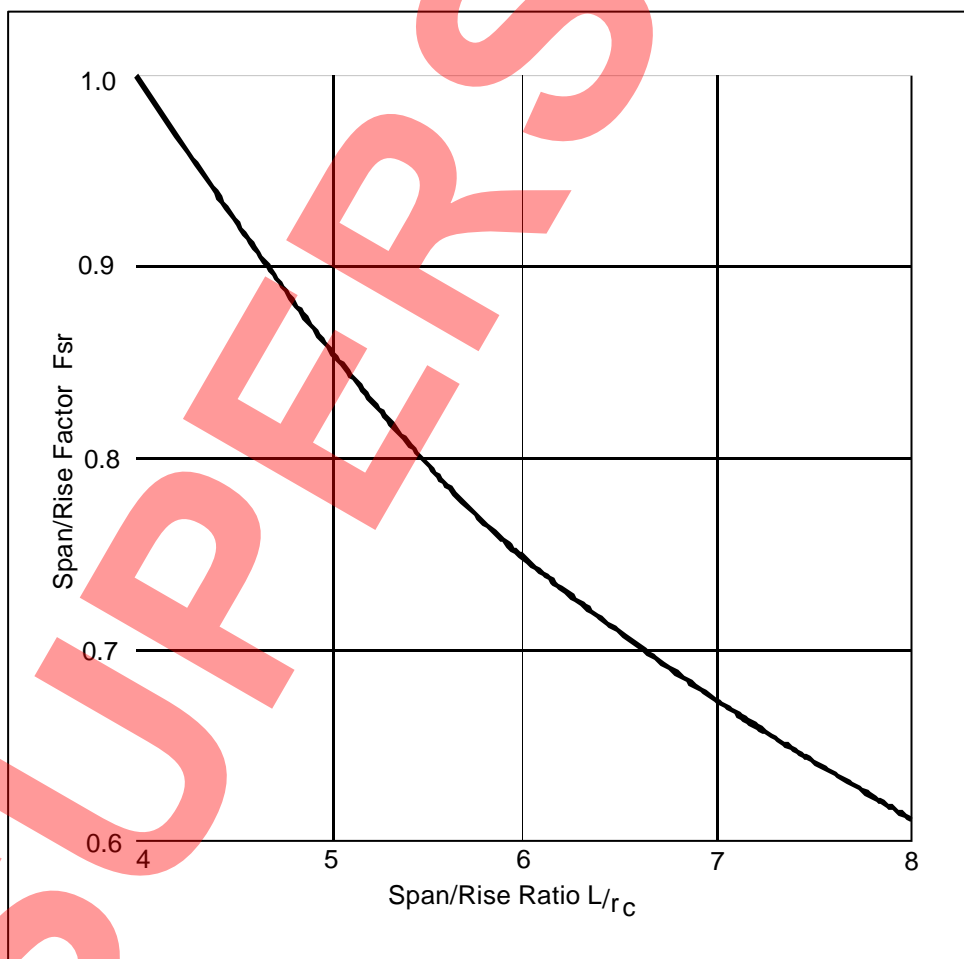

Figure 3/3 Span/Rise Factor

3.13 Material Factor (F_m). The material factor is obtained from the following formula:

$$F_m = \frac{(F_b \cdot d) + (F_f \cdot h)}{d + h}$$

Appropriate values of the barrel factor F_b and the fill factor F_f can be obtained from Tables 3/1 and 3/2 respectively.

3.14 Apart from frost action, an arch which is constantly wet, or shows signs that damp often penetrates, is unlikely to have suffered deterioration from this cause alone unless the seepage contains reactive chemicals which may have affected the materials of construction; in this case allowance should be made in the value taken for the barrel factor. Some local damage may be offset by evidence that the structure was built with good materials and workmanship. Such evidence would be:

- (i) Durable masonry set in its correct bed
- (ii) Well shaped durable bricks
- (iii) Correct bonding of brickwork or masonry with regular and narrow joints
- (iv) Original documents showing liberal haunching at the abutments and a good specification.

3.15 Note should be taken of any leaching from fill material above the arch due to the presence of water. This should be allowed for in the fill factor.

3.16 Joint Factor (F_j). The strength and stability of the arch barrel depend, to a large extent, on the size and condition of the joints. Lime mortar was commonly used in bridge construction. Although it is softer than cement mortar, and has a lower strength, this is compensated for by better joint-filling properties, good load distribution and flexibility for bridge movements and settlement. The joint factor F_j is obtained from the following formula:

$$F_j = F_w \cdot F_d \cdot F_{mo}$$

Appropriate values for F_w and F_{mo} can be obtained from Tables 3/3 and 3/4 respectively. The depth Factor F_d may be taken as 1.0 for pointed joints in good condition. In the case of insufficiently filled joints, it is

recommended that if the depth of missing mortar can be estimated with reasonable accuracy, the thickness of the arch barrel should be reduced by this amount and F_d taken as 1.0. When this is not appropriate, the depth factor F_d may be taken from Table 3/5.

Condition Factor (F_{cM})

General

3.17 The estimation of the preceding factors is based on quantitative information obtainable from a close inspection of the structure, but the factor for the condition of the bridge depends much more on an objective assessment of the importance of the various cracks and deformations which may be present and how far they may be counter-balanced by indications of good material and workmanship. A quantitative estimate of the arch barrel condition factor F_{cM} should be made by the engineer, the value selected being between 0 and 1.0. A low factor should be taken for a bridge in poor condition while 1.0 may be taken for an arch barrel in good condition with no defects. It is important that the engineer dissociates the "condition factor" from the "material factor" and the "joint factor" as these are dealt with separately, as indicated in 3.13 to 3.16. Guidance on the choice of condition factor is given in 3.19 to 3.23 and by reference to the photographs in Annex D. Lower values than those in the suggested ranges may be taken for an arch in a particularly poor state. When an unsound arch barrel supports a large depth of fill, a lower value of the condition factor should be taken than that based solely on the other arch deficiencies.

3.18 The condition factor of the arch, and hence its carrying capacity, can often be improved by carrying out fairly minor repairs. These repairs are distinct from the more elaborate strengthening methods described in 3.1 to 3.7 of Annex C.

Cracks or Deformations

3.19 Cracks or deformations which may have occurred soon after the bridge was built are not usually as serious as those which are recent, and show clean faces, possibly with loose fragments of masonry. A further important point is whether the deterioration is progressive. Where this is suspected, frequent careful observations may be necessary before arriving at a final assessment. Cracks may on occasion be formed in the mortar only and it is important that cracking and joint deficiencies should not be confused with each other.

Arch Barrel	Barrel Factor (F_b)
Granite and Whinstone whether random or coursed and all built-in-course masonry except limestone, all with large shapes voussoirs	1.5
Ashlar quality siliceous sandstone	1.4
Concrete# or engineering bricks and similar sized masonry (not limestone).	1.2
Limestone, whether random or coursed, ashlar quality calcareous sandstone, good random masonry and building bricks, all in good condition.	1.0
Masonry of any kind in poor condition (many voussoirs flaking or badly spalling, shearing etc). Some discretion is permitted if the dilapidation is only moderate.	0.7

Concrete arches will normally be of relatively recent construction and their assessment should be based on the design calculations if these are available.

Table 3/1 Barrel Factor

Filling	Fill Factor (F_f)
Concrete #	1.0
Grouted materials (other than those with a clay content)	0.9
Well compacted materials*	0.7
Weak materials evidenced by tracking of the carriageway surface	0.5

The fill factor for concrete is less than the barrel factor to allow for possible lack of bond to the arch.

* When assessing an arch for Authorised Weight Vehicles, unless details of the fill are known or there is evidence of weakness from the condition of the road surface, it is recommended that this factor be adopted. If the arch then requires a restriction, further investigation should be made to see if the strength may be increased.

Table 3/2 Fill Factor

Width of Joint	Width Factor (F_w)
Joints with widths up to 6mm	1.0
Joints with widths between 6mm and 12.5mm	0.9
Joints with widths over 12.5mm	0.8

Table 3/3 Width Factor

Condition of Joint	Mortar Factor (F_{mo})
Mortar in good condition	1.0
Loose or friable mortar	0.9

Table 3/4 Mortar Factor

Construction of Joint	Depth Factor (F_d)
Unpointed joints, pointing in poor condition and joints with up to 12.5mm from the edge insufficiently filled	0.9#
Joints with from 12.5mm to one tenth of the thickness of the barrel insufficiently filled	0.8#
Joints insufficiently filled for more than one tenth the thickness of the barrel	At the + engineer's discretion

Table 3/5 Depth Factor

Interpolation between these values is permitted, depending upon the extent and position of the joint deficiency. Instead of using this depth factor, it is preferable to reduce the barrel thickness by the amount of missing mortar (see 3.16).

+ See Annex G.

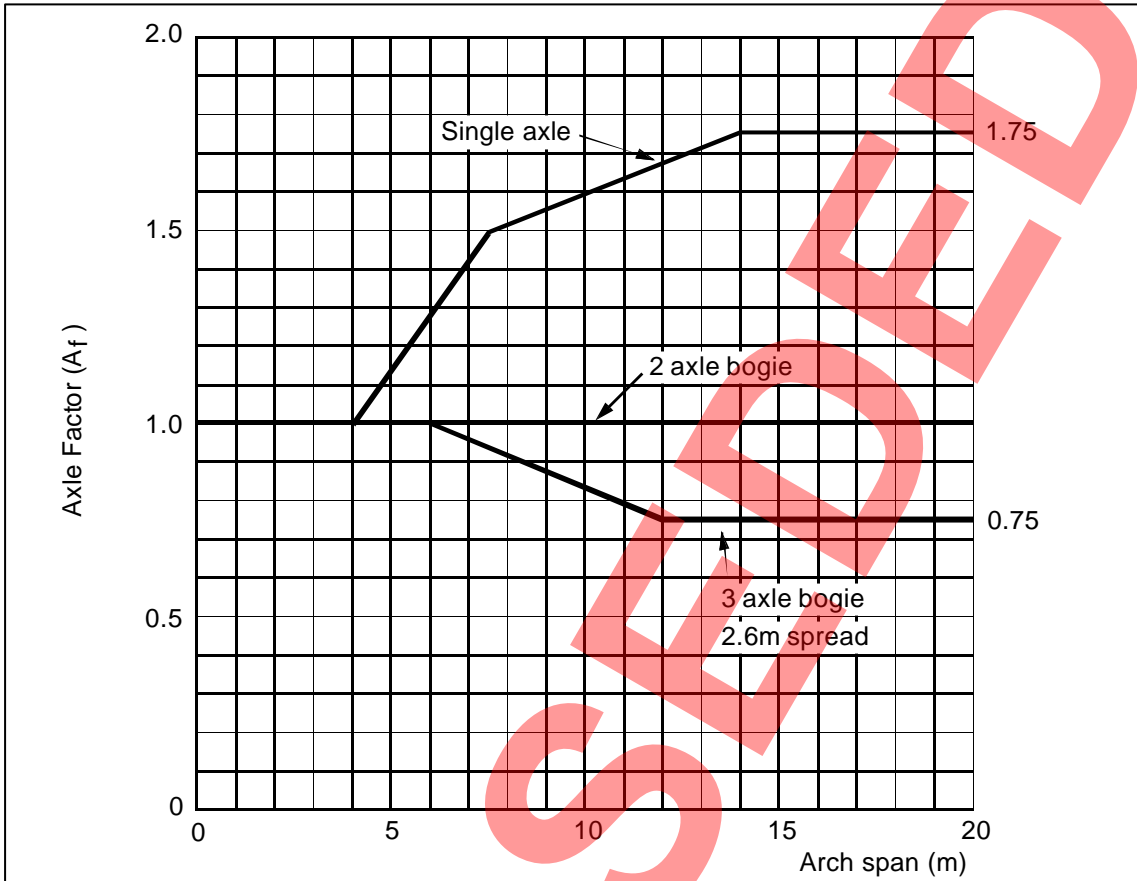

Figure 3/5a No Axle Lift-Off

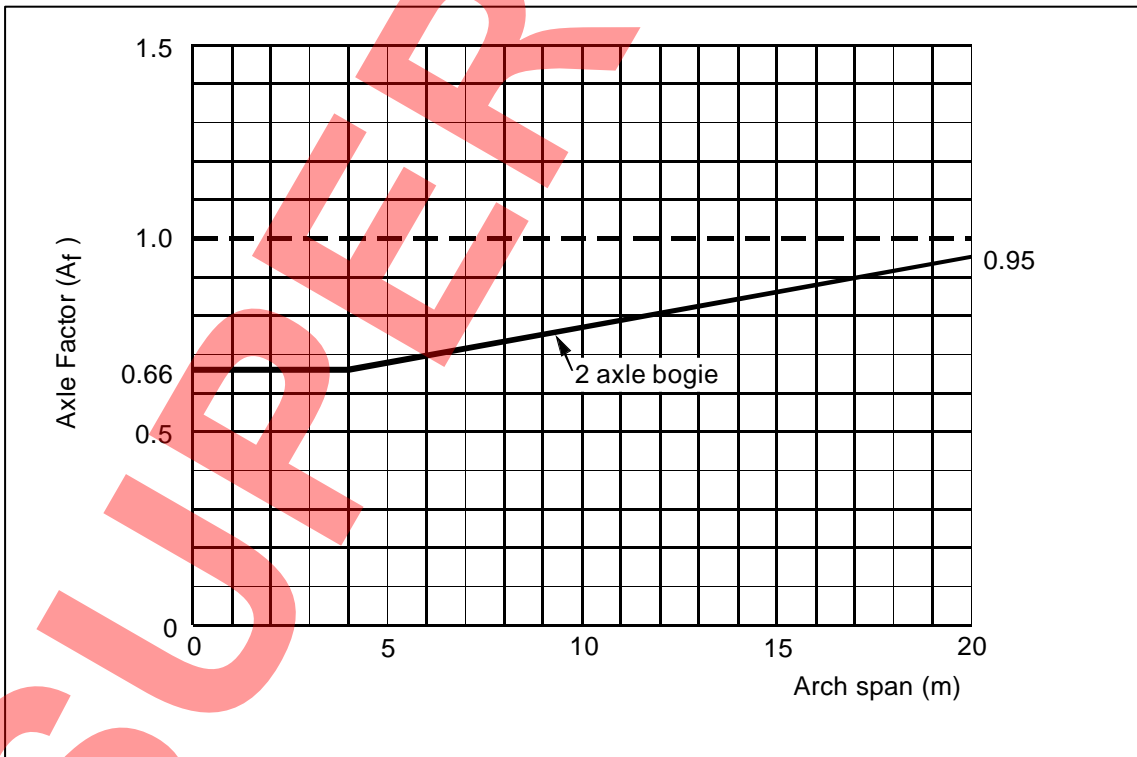

Figure 3/5b With Axle Lift-Off

Figure 3/5 Conversion of Modified Axle Loads to Single, Double and Triple Axles

Allowable Axle Load (tonnes) per axle			Max Gross Vehicle Weight (gvw) (tonnes)	Weight Restriction (tonnes)	Type of Vehicle
Single	Double	Triple			
11.5	10	8*	40/44	N/A	HGV-5 or 6 axles
11.5	9.5	-	32	33	HGV-4 axles
11.5	9.5	-	26	26	HGV-3 axles
11.5	-	-	18	18	HGV-2 axles
9	-	-	12.5	13	
7	-	-	10	10	
5.5	-	-	7.5	7.5	LGV
2	-	-	3	3	Car/Van

Table 3/6 Load Capacity and Gross Vehicle Weight Restrictions for Masonry Arches

* Note: An assessment for the 24 tonne 3 axle bogie (8 tonne axle) is only necessary for arches where 'no axle lift-off' conditions prevail.

Defects

3.20 It is also important to differentiate between those defects which affect the load carrying capacity of the arch barrel and other defects which do not affect the load carrying capacity of the barrel but can affect the stability of the road surface. These are elaborated in 3.21 and 3.22 respectively.

Defects Affecting the Stability and Load Carrying Capacity of the Arch Barrel

3.21 Ranges of condition factors are given below for crack patterns resulting from specific causes. The choice of factor is made from a critical examination of the size, shape and importance of the various defects. The overall figure representing several defects should be based on the relative importance of the worst type of defect present. It will not necessarily be derived by multiplying the factors for several separate defects together:

- (i) Longitudinal cracks due to differential settlement in the abutments. These are dangerous if large, ie $> 3\text{mm}$, because they indicate that the barrel has broken up into independent sections. If the indications are that the barrel is breaking up into 1m sections or less then a factor of 0.4 (or less) should be used. A higher factor should be used for crack spacings greater than 1m. Range of condition factors, 0.4-0.6;
- (ii) Lateral cracks or permanent deformation of the arch which may be caused by partial failure of the arch or movement at the abutments. These faults can be accompanied by a dip in the parapet which may be more easily observed. Range of condition factors, 0.6-0.8;
- (iii) Diagonal cracks. These normally start near the sides of the arch at the springings and spread up towards the centre of the barrel at the crown. They are probably due to subsidence at the sides of the abutment. Extensive diagonal cracks indicate that the barrel is in a dangerous state. Range of condition factors, 0.3-0.7;
- (iv) Cracks in the spandrel walls near the quarter points. These frequently indicate flexibility of the arch barrel over the centre half of the span. Condition factor 0.8. Further information on condition factors is given in Annex G, which also

covers effects of skew and strength of saddled repaired arches.

Unfavourable Defects Not Affecting the Stability of the Arch Barrel

3.22 The unfavourable defects which do not affect the stability of the arch barrel but may affect the stability of the road surface are indicated below, with a description of their significance:

- (i) Longitudinal cracks near the edge of the arch barrel are signs of movement between the arch and spandrel or bulging of the spandrel, caused by the lateral spread of the fill exerting an outward force on the spandrels. This is a frequent source of weakness in old arch bridges and the proximity of the carriageway to the parapet should be taken into account when assessing its importance (see Annex D plate 10);
- (ii) Movement or cracking of the wing walls is another common source of weakness in old bridges and occurs for similar reasons to (i) above (see Annex D plates 9 & 10);
- (iii) Where the bridge consists of multi-span arches and the strength of intermediate piers is in doubt, the structure should be examined for cracks and deformation arising from any weakness in the piers.

Condition Factor Less Than 0.4

3.23 Where the condition factor is less than 0.4 immediate consideration should be given to the repair or reconstruction of the bridge.

Should, for any reason, there be disagreement between the Bridge Owner and the Highway Authority over the value of the condition factor to be taken for an arch bridge, an impartial opinion may be obtained from the Overseeing Organisation.

Application

3.24 The span/rise profile, material, joint and condition factors should be applied together with the provisional axle loading obtained as in 3.10 in order to determine the modified axle load which represents the allowable loading (per axle) on the arch from a double axled bogie configuration with no 'lift-off' from any axle.

MODIFIED AXLE LOAD =

$$F_{sr} \cdot F_p \cdot F_m \cdot F_j \cdot F_{cm} \cdot PAL$$

3.25 The unrounded value of this modified axle load should be multiplied by the appropriate axle factors A_f from Figure 3/5a to give the allowable axle loads for single and multiple axles with no 'lift off'.

Figure 3/5/b gives the axle factors A_f for the 'lift-off' case (see 3.27-3.28). The 2 axle bogie case is the most onerous (see Annex B).

The capacity of an arch should be determined in terms of gross vehicle weights from Table 3/6 in accordance with 3.30 and 3.31.

3.26 It should be noted that these allowable axle loads may not represent the strength of the bridge as a whole. This may be affected by the strength of the spandrel walls, wing walls, foundations, etc (see 3.1). Should the strength of any of these items be assessed as being lower than the barrel strength, then the lowest value should be taken as the strength of the bridge as a whole.

Axle Lift-off

3.27 The axle factors A_f given in Figure 3/5 cover two situations. The first, the 'no lift-off' case, is the more usual when all the wheels of the vehicle are assumed to be in full contact with the road surface at all times. The 'lift-off' case relates to circumstances when the wheels of a double or triple axled bogie can partially lose contact with the road surface and transfer some of their load to other axles in the bogie. Examples of the circumstances which may bring about this phenomenon are given below. The road condition should be inspected to determine whether or not 'lift-off' should be taken into account. The presence of any of the following conditions could lead to the adoption of a 'lift-off' case:

- (i) A vertical road alignment with significant changes from positive to negative gradient over a short distance, eg a humped back bridge;
- (ii) Arch located at the bottom of a hill or on a straight length of road where approach speeds are likely to be high;
- (iii) Irregularities in road surface on the arch.

Derivation of Axle Factors

3.28 The derivation of the Axle Factors is given in Annex B.

Curved Carriageways

3.29 Where the carriageway on an arch is horizontally curved, an allowance for the effects of any increase in vertical loading caused by centrifugal effects should be made by dividing the allowable axle weight by the factor F_A derived in accordance with BD 21 (DMRB 3.4.3). Centrifugal effects may be ignored when the radius of curvature of the carriageway exceeds 600m.

Load Capacity and Weight Restrictions

3.30 To find the load capacity of an arch, the allowable axle loads determined in accordance with 3.24 - 3.29 should first be rounded off to the nearest 0.5 tonnes. The maximum gross weight of the AW vehicles which the arch can carry is then found from Table 3/6. It is the maximum weight for which both the single and, where applicable, the double axle load calculated for the arch are satisfied. It should be noted that when an arch has allowable axle loads which are equal to or greater than 11.5 tonnes for a single axle and 10 tonnes for a double axle (ie 20 tonne bogie) no weight restrictions are necessary for AW vehicles.

3.31 However, the AW Regulations permit heavier triaxles of up to 24 tonnes provided that they are fitted with air or fluid suspensions. A check should also be made to determine whether weight restrictions are needed for these heavier triaxles. Requirements are also given in Table 3/6 to enable arches to be checked for 40/44 tonne vehicles. When weight restrictions are found necessary the restriction signs will apply to gross weights of vehicles and should be signed for one of the weight restrictions given in Table 3/6.

4. ALTERNATIVE METHODS TO THE MODIFIED MEXE METHOD

General

4.1 A number of computer-based methods have recently been developed to assess masonry arch bridges. In a recent exercise, the results from two of these methods, a Castigliano - type elastic method (10.2.5) and a mechanism method (10.2.6) were compared with the results from 10 full-scale tests (10.2.8) carried out through a TRL research programme. A computerised version of the Pippard/MEXE method was also used in the exercise. The details of these comparisons are given in Annex E. However, it should be remembered that, with only a limited number of test results available, such an exercise cannot be regarded as a fully comprehensive evaluation of the methods concerned. The Pippard/MEXE method is described in the rest of this clause; details of the other methods can be found in the references given.

An Elastic Computer-based Method of Assessment for Masonry Arch Bridges

4.2 The following describes a computer-based, two-dimensional elastic method of analysis which is basically a computerised version of the Pippard/MEXE method. It is as simple to use once the parameters for a bridge have been obtained, as for the normal MEXE assessment. This computer approach offers greater flexibility than the MEXE method with respect to geometrical, material and loading parameters. The background work was carried out using the computer program MINIPONT (10.2.7) but for such analysis any other suitable frame-analysis or finite element program could also be employed. An example of the post-analysis calculations is given in Annex F. Of the modifying factors of MEXE, only the Joint and Condition Factors are required for this analysis. It is recommended that this method should be used as an additional tool when a greater accuracy of results is required following a MEXE assessment. In particular, it should be used for marginal cases.

4.3 The method involves separate elastic analyses of the arch as a two-pinned structure separately under dead and live loads. Although only a unit width is analysed, the results are to be converted to make allowance for the effective arch width due to the transverse spread of wheel loads. The ultimate live load capacity is calculated to be the load at which the maximum

compressive fibre stress at any section reaches the characteristic compressive strength of the masonry concerned. In order to obtain the allowable live load, the ultimate capacity is then reduced by a condition factor which is equal to the product of F_j and F_c of the modified MEXE method and the partial safety factor for load γ_f , given in BD 21 (DMRB 3.4). The method has given uniformly acceptable correlation with full-scale test results and allows Pippard's basic theoretical method to be carried out in full without the need for the various approximations which were incorporated into the MEXE method. However, it should be used only when there is well-compacted fill between spandrels and must not be used for open spandrel bridges. When there is evidence of heave or cracks at the road surface, reduction factors such as the Fill Factor of the modified MEXE method should be applied.

Arch Ring Idealisation

4.4 The arch ring should be represented along its centreline by a number of line elements (which may be straight) in the spanwise direction and with pinned supports assumed at the springings. The number of elements should be chosen so that the critical nodal bending moments become convergent with respect to increase of elements. Twelve elements may be sufficient in most cases. It has been found that the 1/3 span section is usually the most critical section for determining axle load capacity and therefore a node should be located at the 1/3 span position of the arch ring. Figure 4/1 shows a typical example of idealisation. In the transverse direction, a unit width should be assumed.

Application of Loads

4.5 The analysis should be carried out in two steps: one with dead load and another with applied unit live load. The dead load from the fill and masonry may be applied as joint loads. The live load may be applied as either joint loads or, preferably, as member uniformly distributed loads. The load applied to the road surface should be dispersed through the fill and arch material at slopes of 2 vertical to 1 horizontal. This load may be assumed to be a uniformly distributed vertical load on the horizontal projection of each segment of the arch centreline which falls within the dispersal lines.

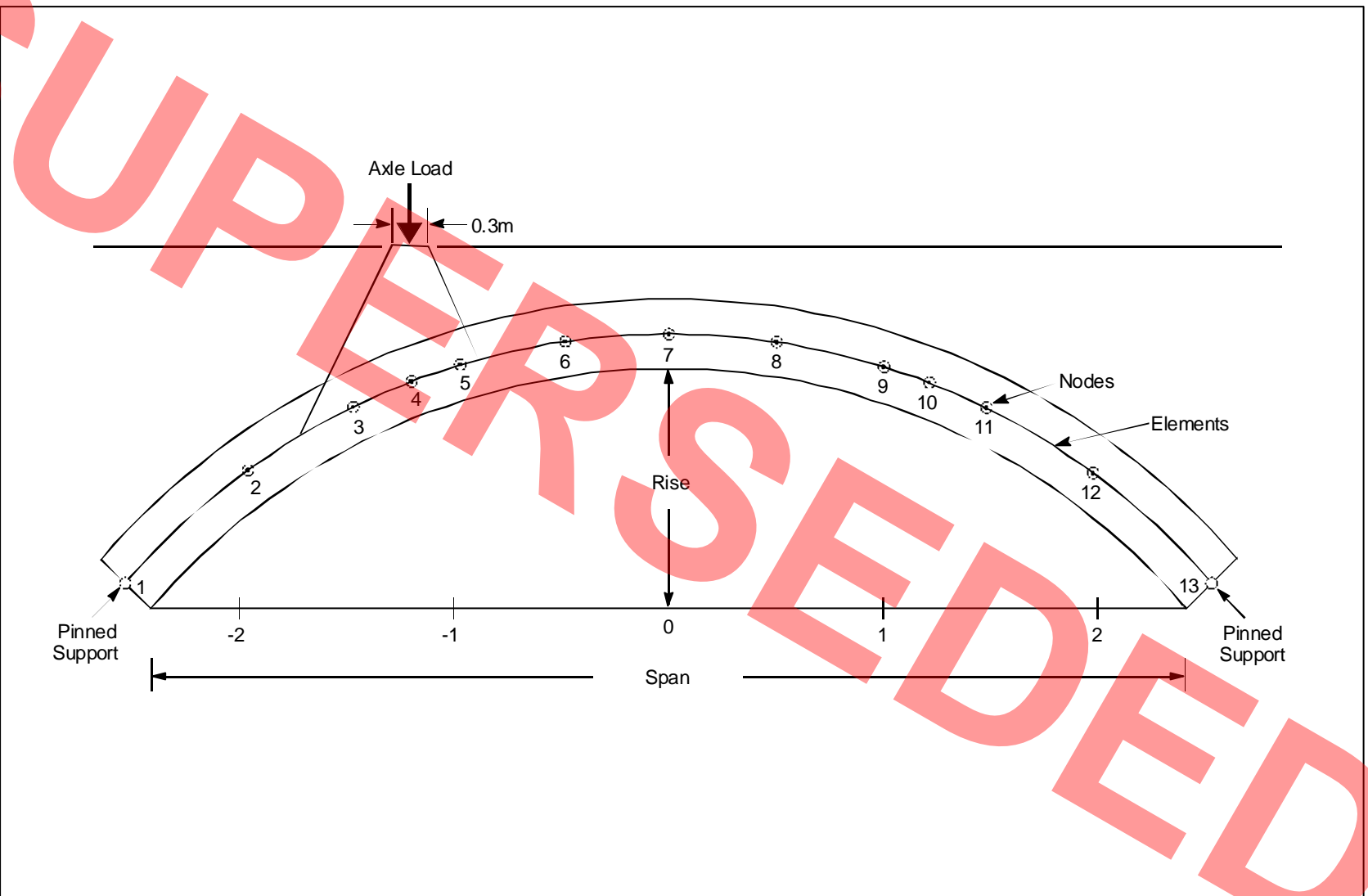

Figure 4/1 Arch Ring Idealisation

Transversely, the effective width w of the arch barrel carrying a wheel load applied at any position along the span can be derived (as shown in Figure 6.4 of BD 21 (DMRB 3.4.3)) from the approximate formula:

$$w = h + 1.5$$

Where h is the fill depth at the point under consideration and both w and h are in metres. The combined effective width for a number of wheel loads located transversely on the carriageway can be derived as shown in Figure 6.4 of BD 21 (DMRB 3.4).

4.6 The method is applicable for the assessment of any axle configuration. Figure 4/2 shows an influence line for the critical load effect at the 1/3 span section of the structure with respect to a moving axle load. As a first approximation the worst position of an axle configuration can be determined using this influence line.

4.7 When an assessment for AW vehicles is carried out, the allowable load may be determined in terms of a single axle by using the elastic method and then the allowable multiple axle loads are derived from the single axle case by using Figure 3/5. The capacity in terms of gross vehicle weights should be determined from Table 3/6 in accordance with 3.30 and 3.31.

Compressive Strength of Masonry

4.8 The ultimate compressive strength of the composite masonry, as opposed to that of the voussoir units, is to be used in the analysis. Requirements concerning masonry strengths and testing procedures are given in BD 21 (DMRB 3.4.3). The compressive strength of the masonry should be determined as accurately as possible. For critical cases, in the absence of any other reliable information, core samples should be taken in order to determine the compressive strength of the voussoir units. When using BS 5628 to obtain compressive strength the tables for concrete block masonry may be considered to apply for stone masonry. Where stone units are thinner than those allowed for in BS 5628: Part 1, Figure 4/3 of BD 21 (DMRB 3.4.3) should be used.

Ultimate Load Capacity of the Arch

4.9 The assumption implicit in the method of 4.2 and 4.3 is that the live load capacity of an arch bridge can be obtained by analysing it as a two-pinned arch and using the criterion that the ultimate load capacity is reached when the total dead and live load compressive

stress at any section, calculated using the full depth of section, equals the ultimate compressive strength of the masonry. The combined dead and live load axial and bending compressive stresses at the critical section are equated to the characteristic compressive strength of the masonry to obtain the theoretical maximum load at failure.

Allowable Load

4.10 Work carried out by the Department of Transport as well as by British Rail has indicated that the MEXE provisional axle loads (PAL) are based on Pippard's allowable axle loads which were calculated to be those producing the permissible masonry compressive stress in the arch barrel. The MEXE PALs, which correspond to the ideal bridge, are multiplied by the Modification Factors in order to make them pertinent to a particular structure. Similarly, the theoretical maximum failure load, which is basically the Pippard load at the ultimate masonry compressive stress, needs to be converted to a theoretical failure load pertinent to the actual structure by using deterioration factors such as the Joint Factor, F_j and Condition Factor F_{cM} of the MEXE method. The other Modification Factors of MEXE are directly taken care of within the computer analysis.

4.11 It is recommended that, for a single axle, the allowable axle load should be obtained using the following formula:

$$\text{Allowable single axle load} \times \gamma_{fL} = \text{Theoretical maximum single axle failure load} \times F_j \times F_{cM}$$

$$\text{where } \gamma_{fL} = 3.4$$

4.12 When multiple-axle AW vehicles are used for more precise calculations, the check for adequacy should be carried out at the ultimate limit state (ULS). A γ_{fL} value for the most critical axle should be taken as 3.4 and for the other axles as 1.9. When the configuration of a vehicle at the time of crossing is known with some precision, as in the case of some abnormal loads, γ_{fL} for all axles may be taken as 2.

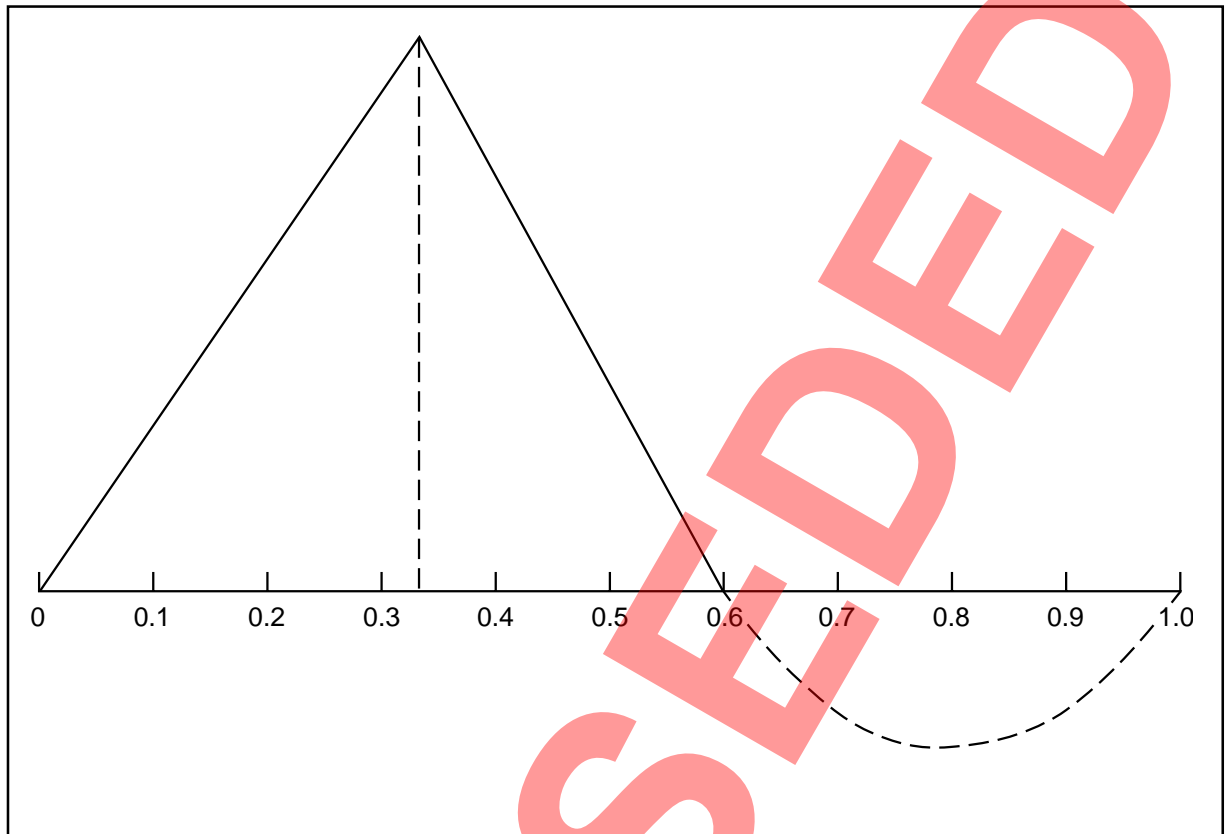

Figure 4/2 Influence Line for Determining Critical Load Position

5. SPANDREL WALLS AND DRY-STONE WALLS

General

5.1 The adequacy of spandrel walls and dry-stone walls will generally be assessed qualitatively and be based on the results of visual inspection of the structures, including the significance of any defects. The particular details of the two types of wall and the seriousness of the various defects which can occur are described in 5.2 to 5.10. Various remedial measures for the different faults are discussed in Annex C.

Spandrel Walls

5.2 Spandrel walls are normally formed from dressed material and suffer the normal problems associated with exposed masonry: weather, loss of pointing, etc. In addition, deterioration of bridge spandrels is frequently a function of dead and live load lateral forces generated through the bridge infilling or as a result of direct vehicular impact. In both cases some outward movement is caused. Lateral forces may cause the wall to rotate outward from the arch barrel, to slide on the arch barrel, to be displaced bodily outwards whilst taking part of the arch ring with it, or to bulge (see Figure 5/1 and Annex D plates 9 and 10).

5.3 Dry-stone spandrel walls are not common. Where they occur there are difficulties which are similar to those of retaining walls, but the effects of live loading are more significant.

5.4 Spandrel walls are more vulnerable to damage or displacement if no footway exists to restrain vehicles passing close to the side of the bridge. Without footpaths, vehicular impact is more likely and the effects of the lateral loading generated by the vehicle through the bridge fill may be more acute.

5.5 Poor bridge drainage may also be a feature leading to deterioration of the spandrel, particularly if saturation of the bridge fill occurs. Work on Statutory Undertakers' and Private Utilities' equipment passing through the bridge may also lead to deterioration of the spandrels by permitting an increase of water percolation into the fill, thereby reducing the shear strength of the fill.

Dry-stone Walls

5.6 Construction and Behaviour. Inspection of dry-stone walls reveals that they are normally constructed without recognisable foundations and out of marginal quality material. Only the front face contains dressed masonry, the remainder usually being rubble. Dry-stone walls were constructed as facing walls to vertical or near vertical cuts in unstable or friable material or as free-standing burr and retaining walls. In the latter cases construction and backfilling proceeded together.

5.7 The behaviour of dry-stone walls is a function of their method of construction. The absence of mortar results in stone to stone contact, and since the stones used in the walls are usually irregular or roughly squared off, point contact between stones is common. Contact pressure may be high especially at the base of tall stones and crushing is often evident. The open nature of a dry-stone wall permits weathering of the face and in the open joints, reducing the area of contact and encouraging further crushing. In addition, percolation of ground water and water-borne salts through the fabric of the wall results in weathering and the leaching of fines from within the structure. Salt spray resulting from de-icing salts may cause deterioration in the fabric of the lower parts of the wall.

5.8 Weathering occurs more in some areas of wall than in others due to the very variable quality of the masonry used. Random weathering and unsatisfactory foundations results in differential settlements, movements and bulging which induces acute stresses in some elements of the structure causing cracking whilst elsewhere stones become loose and may be dislodged.

Assessment of Dry-stone Walls

5.9 Assessment of dry-stone walls consists of regular visual inspection and a comparison with adjacent structures. Qualitative judgements are difficult since conditions will vary greatly with the quality of stone used, age, subsoil conditions, geometry, weathering factors and local expectations. Due attention should be given to local engineering experience.

5.10 Where past movement or the condition of the structure raise doubts concerning stability, regular monitoring should be introduced. Decisions relating to

structural safety and conditions often depend upon engineering instinct, although simple visual aids such as tell-tales can be useful to determine if the structure is moving or in a temporary equilibrium.

5.11 Additional guidance on the assessment of dry-stone retaining wall is given in Annex H.

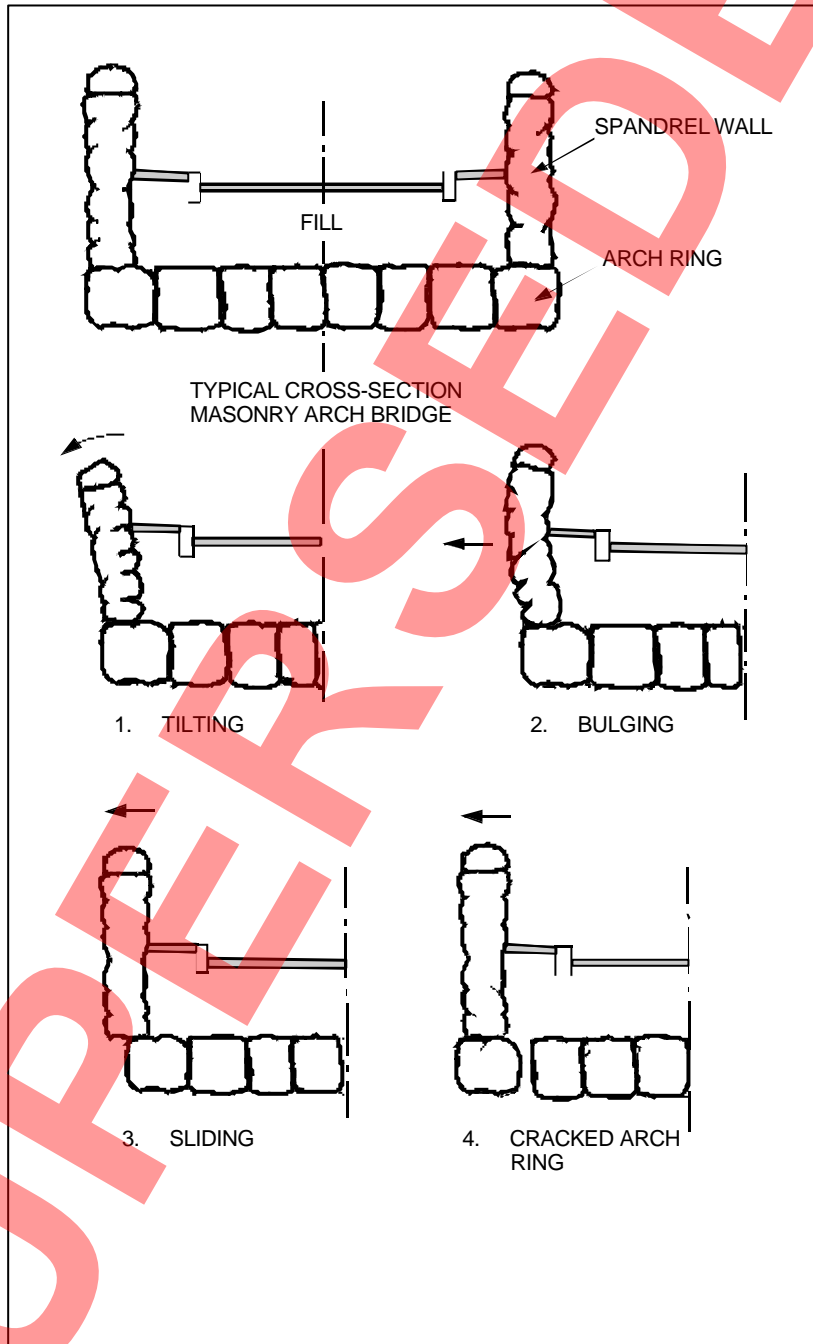

Figure 5/1 Spandrel Wall Failures

6. SUB-STRUCTURES, FOUNDATIONS AND RETAINING WALLS

General

6.1 The adequacy of a sub-structure, foundation or a retaining wall is usually determined from a qualitative assessment of the general condition of the structure, including the significance of any defects. In carrying out such an assessment particular attention should be paid to the items described in 6.2 to 6.7.

Dimensions

6.2 Before assessment can proceed, dimensional checks are required on the sub-structure, foundations or retaining wall for preparing sketches for analysis or for confirmation of the 'as-built' drawings. These dimensional checks may require excavation or probing to determine depth and the extent of the sub-structure and foundations. Care must be exercised to ensure that no exploratory work impairs stability or damages underground services.

6.3 In some instances exploratory excavations, probing or boring may not be practicable prior to assessment. In these cases, if an assessment is required conservative estimates may have to be made regarding the probable dimensions of the sub-structure, foundations or retaining wall based only upon visual evidence.

Bearings, Abutments and Retaining Walls

6.4 In many early bridges, bearings were omitted; in others only rudimentary forms of bearing were provided. As part of the assessment the existence and efficiency of the bearings should be established. Where no bearings exist or their efficiency is impaired, the ability of a bridge to cater for thermal movements and forces should be considered.

6.5 Tilting or rotation in any direction of piers, retaining walls and abutments may be determined using normal survey techniques. If there are any indications of damage due to possible thermal movement, this may be confirmed by using laser techniques.

Water Scour

6.6 Flow of water can cause leaching and scour from foundations and sub-structures. Any sight of unexpected or unintended water flows should be investigated, the cause established and any resultant deterioration determined.

6.7 Underwater inspection in slow moving water may be undertaken by divers, or using flexible dams or cofferdams. The latter may have the advantage of providing dry conditions for repairs should they be required. In fast moving water damming may be impracticable. Where clarity of water permits, underwater photography or television is of particular assistance to the engineer in establishing conditions below water level. It should be noted that the depth of any scour holes which may occur during a flood are generally greater than those observed during periods of slack water. Evidence of the natural refilling of scour holes is sometimes available if material of a coarser or differing nature is present within the scour zone.

7. JACK ARCH BRIDGES

7.1 Experimental findings indicate that, with the presence of strong fill materials above jack arches, it may be reasonable to assume composite action between the metal members and the fill when assessing such structures. When the structure is found to be inadequate following an initial conservative assessment (ie without taking into account such composite action), the following procedure may be followed:

7.2 An alternative and less conservative method for assessing jack arches is given in BA 61 (DMRB 3.4.17).

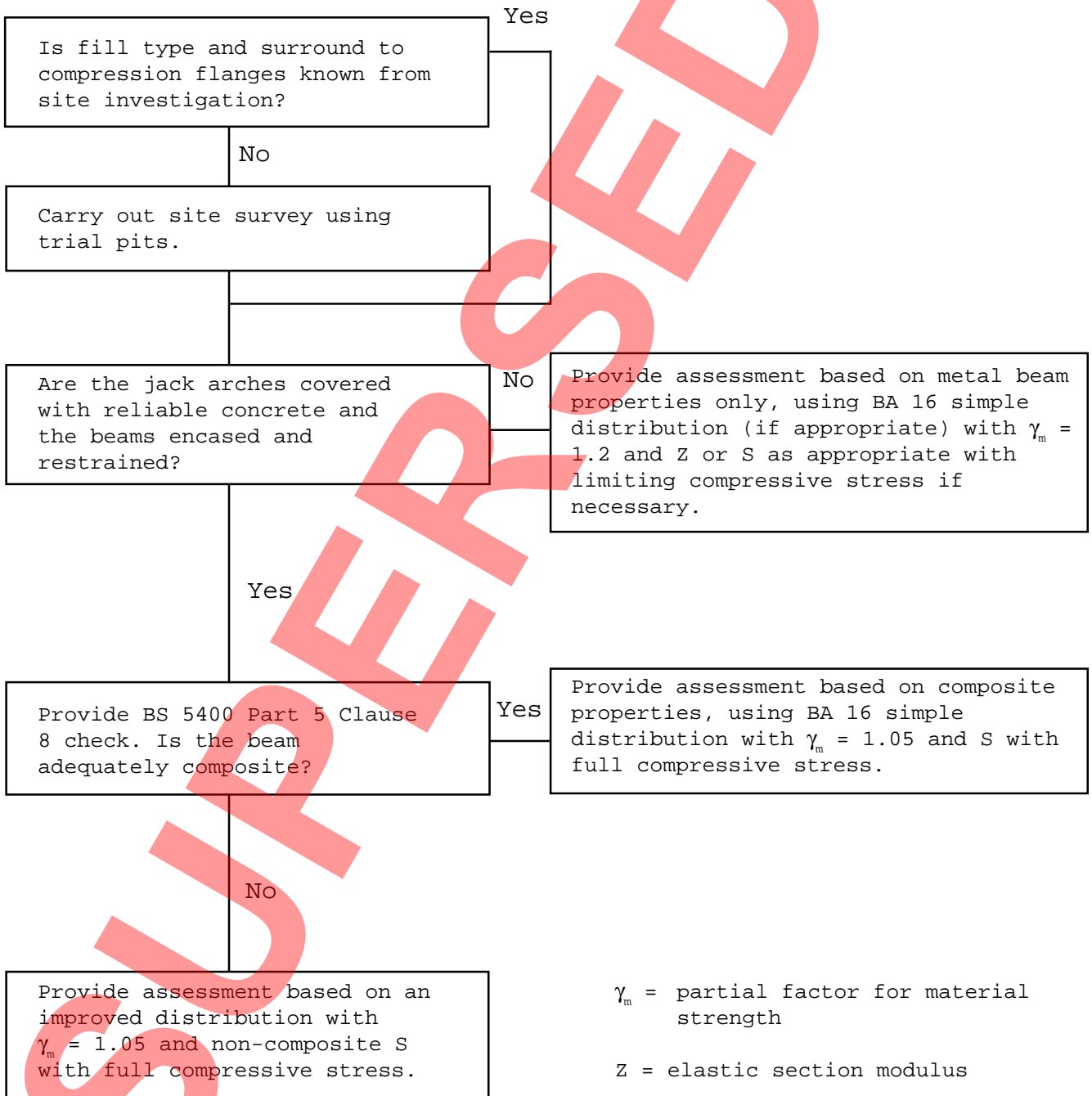

γ_m = partial factor for material strength
 Z = elastic section modulus
 S = plastic section modulus

8. METAL BRIDGES

8.1 With respect to bearing zones at supports, the following criteria for the assessment of simply-supported bridges containing rolled members and plate girders over short spans may be used:

- (i) for bridges under 10m span, load combinations 3 and 5 of BD 37 (DMRB 1.3) may be ignored;
- (ii) bridges between 10m span and 15m span require a careful assessment of their intended articulation (ie ability to rotate or slide) with respect to the effects of live load and temperature and with particular reference to the condition of the structure. Calculations need only be provided where it is suspected that the performance and integrity of the structure may not be satisfactory as a result of any changes in articulation;
- (iii) rolled sections in filler joist slab construction do not need to be checked for compliance with bearing stiffener requirements;
- (iv) in structures of less than 10m span, the requirement to apply an additional moment M_y as required in BD 56 (DMRB 3.4.11) Annex A Clause 9.14.3.4 may be ignored when checking webs with or without bearing stiffeners.

9. TROUGH DECK BRIDGES

Analysis

9.1 The BD 21 (DMRB 3.4.3) rules regarding the dispersal of live load to a number of troughs are considered to be adequate or conservative for bridges where the carriageway is at least 3 webs of troughing away from the edge. However, where live loading is required to be closer to the edge, a grillage analysis, with each web and its associated flanges modelled individually, is recommended. Grillage analysis is also recommended for bridges of spans of 4m or less and for bridges with transversely spanning troughs having a fill depth of 300 mm or more. In these latter cases, the BD 21 (DMRB 3.4.3) rules may be unconservative.

Transverse Bending Rigidity

9.2 When using a grillage analysis, in areas of the deck where the transverse bending moment is sagging, the transverse bending rigidity may be enhanced in alternative elements to take account of the composite action of the concrete trapped within the webs.

Compact/Non-compact Designation

9.3 The sections of Lindsay troughing as adopted by Dorman Long are considered to be essentially compact. Built up sections, however, may not be. In such cases, it may still be possible to calculate the ultimate resistance of members using the plastic modulus of the section provided it is certain that the fill will provide restraint against buckling after the onset of plastic flow.

10. REFERENCES

1. Design Manual for Roads and Bridges (DMRB): The Stationery Office Ltd.

Volume 1: Section 3 General Design

BD 10 Design of Highway Structures in Areas of Mining Subsidence (DMRB 1.3)

BD 37 Loads for Highway Bridges (DMRB 1.3)

Volume 2: Section 4 Paints and Other Protective Coatings

BD 35 Quality Assurance Scheme for Paints and Similar Protective Coatings (DMRB 2.4.1)

BA 27 Quality Assurance Scheme for Paints and Similar Protective Coatings (DMRB 2.4.2)

Volume 3: Section 3 Repair

BD 27 Materials for the Repair of Concrete Highway Structures (DMRB 3.3)

BA 35 The Inspection and Repair of Concrete Highway Structures (DMRB 3.3)

Volume 3: Section 4 Assessment

BD 21 The Assessment of Highway Bridges and Structures (DMRB 3.4.3)

BD 56 The Assessment of Steel Highway Bridges and Structures (DMRB 3.4.11)

BA 61 The Assessment of Composite Highway Bridges and Structures (DMRB 3.4.17)

2. Other Documents referred to:

2.1 Military Engineering Experimental Establishment - "Classification (of Civil Bridges) by the Reconnaissance and Correlation Methods" - Christchurch (MEXE), May 1963.

2.2 Hendry, A.W., Jaeger L.G. - "The Analysis of Grid Frameworks and Related Structures" - Chatto and Windus, 1958 (rept 1969).

2.3 Thomas F.G., and Short A. - "A Laboratory Investigation of Some Bridge-Deck Systems" - I.C.E. March 1952.

2.4 Pippard A.J.S. - "The approximate estimation of safe loads on masonry bridges". Civil Engineer in War, Vol 1, 365. Inst. Civ. Engrs, London, 1948.

2.5 Bridle R.J. and Hughes T.G. - "An energy method for arch bridge analysis". Proc. Inst. Civ. Engrs, London, Part 2, 1990.

2.6 Heyman J. - "The estimation of the strength of masonry arches" - Proc Inst Civ. Engrs, London, Part 2, Dec 1980.

2.7 MINIPONT User Manual, Highway Engineering Computer Branch, Department of Transport, London, 1975. (Software is not commercially available).

- 2.8 Page J. - "Assessment of masonry arch bridges". Proceedings of the Institution of Highways and Transportation National Workshop, Leamington Spa, March 1990.
- 2.9 Harvey W.J. - "Application of the mechanism analysis to masonry arches". The Structural Engineer, Vol 66, No.5, March 1988.
- 2.10 Choo B.S. et al - "Finite-Element analysis of masonry arch bridges using tapered elements". Proc. Inst. Civ. Engrs, London, Part 2, Dec 1991."

3. Useful additional references (see Annex C):

- 3.1 Hsiong Wei "Repair of Poplar Street Complex Bridges in East St. Louis". Trans.Res.Rec. 664. Bridge Eng. Vol 1. Washington DC. 1978
- 3.2 Jones C.J.F.P. and Spencer W.J. "The implications of Mining Subsidence for Modern Highway Structures". Conference on large ground movements and structures, Cardiff. 1977
- 3.3 Koretzby H.P. "What has been learned from the first Prestressed Concrete Bridges - Repair of Such Bridges". Tran.Res.Rec 664. Bridge Eng Vol 1, Washington DC. 1978
- 3.4 Tilly G.P. "Fatigue Problems in Highway Bridges" Trans.Res.Rec 664. Bridge Eng. Vol 1. Washington DC. 1978
- 3.5 Forde M.C. and Topping B.H.V. International Conference on Structural Faults and Repair, Engineering Technics Press. Proceedings of the Second. 1985
- 3.6 Forde M.C. Proceedings of the International Conference on Structural Faults and Repair - Volumes 1 and 2, Engineering Technics Press. 1987
- 3.7 Page J. "A guide to repair and strengthening of masonry arch highway bridges", TRL Report 204. 1996

4. The following computer program is referred to in the text of this Advice Note:

MOT/EBP/250C - GRIDS Program for the grillage analysis of slab or pseudo-slab bridge decks: Highway Engineering Computer Branch, Department of Transport.
(Software is not commercially available).

11. ENQUIRIES

All technical enquiries or comments on this Advice Note should be sent in writing as appropriate to:

Head of Civil Engineering
The Highways Agency
St Christopher House
Southwark Street
London SE1 0TE

G BOWSKILL
Head of Civil Engineering

Chief Road Engineer
Scottish Executive Development Department
Victoria Quay
Edinburgh
EH6 6QQ

J HOWISON
Chief Road Engineer

Chief Highway Engineer
The National Assembly for Wales
Cynulliad Cenedlaethol Cymru
Crown Buildings
Cathays Park
Cardiff CF10 3NQ

J R REES
Chief Highway Engineer

Assistant Director of Engineering
Department for Regional Development
Roads Service
Clarence Court
10-18 Adelaide Street
Belfast BT2 8GB

D O'HAGAN
Assistant Director of Engineering

ANNEX A

DERIVATION OF DISTRIBUTION FACTORS AND EQUIVALENT AXLE LOADS IN CHAPTER 2

Longitudinal Members

A1. The proportion factors given in Chapter 2 for longitudinal members are based on the theoretical approach of Hendry and Jaeger (10.2.2) and the test results and recommendations given by Thomas and Short of the Building Research Station (10.2.3). It was found that using Hendry and Jaeger's method with a value of EL_T/EI of 0.0305 (see page 19 of ref 10.2.2) and a value of $\beta = \infty$ gave exact correspondence with the distribution in the model jack arch bridge described in Thomas and Short's paper. Fair correspondence was also obtained for two bridges tested in 1943.

Proportion factors for internal and external girders were therefore calculated by Hendry and Jaeger's method for various girder spacings and spans up to 9.0m using this constant value of EL_T/EI . Due to a lack of experimental data on old types of bridges beyond 9.0m span, the proportion factors calculated for 9.0m span were conservatively adopted for all greater spans.

The different approach of Thomas and Short was then used to calculate similar sets of proportion factors which were plotted in conjunction with the previous sets. Envelopes were then drawn embracing the two sets of values calculated and the factors obtained were plotted in the form shown in Figures 2/3 and 2/4.

The factors were originally derived for a loading which consisted of trains of vehicles. It has been assumed that these factors are also applicable to the current assessment loading consisting of a UDL plus KEL since, although this loading is presented in a different format, it nevertheless represents the actual traffic loading consisting of individual vehicles.

Transverse Members

A2. The equivalent axle loads have been derived to give the same bending moments or shear forces in a single girder (either internal or external) as those that would be produced by 40/44 tonne vehicles or C&U vehicles, now covered by AW vehicles, on a set of girders spanning between rigid parapet girders. They were derived for various girder spacings and spans using the grillage computer program GRIDS (10.4) and taking account of the effect of the different vehicle types which comply with the then C&U Regulations.

The distribution properties of transverse girder and jack arch decks have been modelled in GRIDS by using a ratio of EL_T/EI of 0.0305 x 3.28 per metre length of cross girder to represent the ratio of the stiffness of the grillage members. This ratio was used for all girder spacings and spans.

An equivalent axle load has been taken to represent the loading from a single lane of traffic and allows for impact and overloading. The number of equivalent axles applied was the number of 2.5m wide lanes carried by a cross-girder. However, the full load from only two axles was taken on a girder; the effect from more than two lanes of traffic was reduced by applying a factor of 0.6 to the other axle loads. The reduction factors for other Assessment Live loadings were derived by comparing the bending moments and shear forces obtained from GRIDS due to the loading imposed by vehicles complying with the Assessment Live Loading categories with those effects obtained from the worst of the C&U and 40/44 tonne vehicles, now covered by AW vehicles.

ANNEX B

EFFECTS OF MULTIPLE AXLES ON ARCHES

Introduction

B1. The modified MEXE method for arch assessment makes use of a nomogram from which it is possible to derive, for a particular arch, a provisional allowable axle load of an axle forming part of a double axled bogie. This load is then modified by various factors to allow for the shape of the arch, construction materials, dimensions of the arch barrel and any defects. However, because a proportion of heavy vehicles now have triple axles, a simple method of relating the effect of different axle configurations to double axles is needed so that the carrying capacity of the arch can be derived for all types of vehicle.

Theory

B2. Examination of the stress influence lines for typical arches reveals the following:

- (i) at positions away from the crown there is little difference in the influence line shapes between a two pinned and a three pinned arch;
- (ii) for a two pinned arch the dead load bending moment increases the live load moment at the 1/3 point but relieves the moment at the crown;
- (iii) peak values for stress in the arch ring for both two and three pinned arches occur under a concentrated load placed between about 0.1 and 0.35 of the span away from a springing point.

These observations led to the conclusion that the critical position for comparing the effects of different axle configurations could be taken as the 1/3 point. Examination of the influence lines also shows that the influence line for maximum stress at the 1/3 point is very similar in shape to that for the mid-point bending moment of a simply supported beam of span equal to half the arch span. Thus there is a simple method of comparing the effects of different axle configurations by comparing the bending moments due to the different loading configurations on a simply supported beam whose length is equal to half the arch span.

Axle Factors

B3. The comparisons between single and multiple axles have been made as outlined above for single axle and two and three axled bogies whose weights and spacings represent the extremes of those allowable under the AW regulations. The basis of the method has been a comparison of the then C&U configurations with the double axle bogie that was used in the derivation of the MEXE nomogram. Two sets of comparisons have been undertaken, which consider the no 'lift-off' and 'lift-off' cases. The 'no lift-off' case assumes equal distribution of loading between the axles of the bogie. The 'lift-off' case was considered because, although bogies are fitted with compensating mechanisms to share the load between all the axles, it was felt that some allowance should be made for possible axle 'lift-off' which could occur for example at the crown of a sharply humped bridge. Research has indicated that, for three axled bogies, the load transfer takes place between the two outer axles, the centre axle weight remaining constant. Accordingly for the three axle 'lift-off' case, half the weight of one outer axle has been transferred to the other outer axle. For two axled bogies it has been assumed that half the weight of one axle is transferred to the other axle.

It was found that the extreme effects of the two axled configurations also covered the three axled bogies up to 22.5 tonnes complying with the then C&U Regulations. The worst case results for single axle and two axled configurations are therefore shown in Figure 3/5 where the axle factors are plotted against the arch span. The AW Regulations permit heavier three axled configurations of 24 tonnes with air or fluid suspension.

Additional factors have therefore been included in Figure 3/5a no 'lift-off' case to enable assessments for the heavier three axled bogies to be carried out as these may prove to be the more onerous configuration. These factors are not given in Figure 3/5b 'lift-off' case because the improved compensatory performance of the air or fluid suspension ensures that the effects of the heavier three axled bogies are no worse than the 22.5 tonne configuration.

SUPERSEDED

ANNEX C

MAINTENANCE AND REPAIR

Introduction

- C1. Maintenance required for highway bridges may be due to any of the following:
- (i) as a result of fair wear and tear;
 - (ii) as a result of poor detailing;
 - (iii) as a result of lack of waterproofing;
 - (iv) as a result of substandard design, workmanship and materials;
 - (v) as a result of damage caused by accident, ground movements, mining subsidence or flood;
 - (vi) as a result of the use of de-icing salts;
 - (vii) as a result of heavy vehicular use or incorrect management of the highway.

In the context of this section, fair wear and tear covers such items as regular painting, attention to drainage defects and readjustments to bearings. Some problems are a direct result of poor detailing, but others stem from the repetitious use of particular solutions which are ultimately found to be unsatisfactory. The latter may be the result of inadequate design or substandard workmanship and materials. With modern bridges these defects frequently become apparent 10-20 years after original construction.

Damage caused by an outside agent can be severe. Vehicular impacts are becoming more serious, whilst geotechnical movements such as those resulting from mining subsidence may prove particularly destructive to some forms of structure, eg arch bridges.

The action of de-icing salts in causing deterioration of bridge structures is now widely recognised. Unfortunately, the severity of this problem may not have been appreciated during the design of much of the earlier stock of bridges and the necessary precautions may not have been specified. In particular, the lower quality concrete used in some elements of bridges is resulting in a sufficient concentration of chloride ions in the concrete to cause corrosion of the embedded reinforcement.

It is axiomatic that increased use of a bridge will increase wear and tear. Due to modern-day traffic, some bridges carry large numbers of heavy vehicles which cause deterioration at a greater rate than that experienced in their early life. In these cases inspection and maintenance practices may need to be reviewed.

In the past, poor management of the highway has sometimes resulted in damage to highway structures. The practice of increasing surface thickness on bridges each time the adjacent highway surface is repaired leads not only to an increase in dead load but often results in structural members being buried in a corrosive environment.

Repairs and Strengthening

- C2. Repair solutions can differ markedly, depending upon the extent and the type of damage. For example, if a span of a footbridge is entirely removed by vehicle collision, a temporary replacement may have to be provided whilst a new span is being manufactured for the permanent reinstatement. Repairs to a structure which is intact and

useable should be carefully detailed so that they are effective and can be executed safely and with the minimum of disturbance to users of either the structure or the facility beneath. Possible methods of repair for different types of structure are described in Section 3 with comments on their suitability in particular circumstances.

For further information on concrete repairs refer to BD 27 (DMRB 3.3) and BA 35 (DMRB 3.3).

Arches

General

C3.1 Masonry arches are able to accommodate substantial cracking, deformation and overstress before they reach the point of collapse. Cracks in the arch barrel can often be repaired by guniting, thus allowing an improved condition factor to be adopted for the arch assessment (see 3.18 to 3.23). Consequently, it is usually only in cases of severe mining subsidence, impact or undercutting by floodwater that they become damaged beyond economic repair. The following notes in C3.2 to C3.7 briefly review some of the techniques which have been found useful in repairing or strengthening arch bridges.

Abutments and Piers

C3.2 A system of small diameter bored piling has been shown to be an extremely useful means of providing extra support needed to limit settlement or where additional loading is anticipated. In order to provide continuity, the piles are bored through and cast into the existing abutment. Where the abutment itself is weak it may require grouting or stitching together by some means, an example being the system as shown in Figure C/1.

Many arch bridges were built on very shallow foundations. This leads to frequent undercutting due to scour, and if underpinning is required it is prudent to build a concrete apron or invert slabs around the abutments or pier in order to protect the toe of the masonry, Figure C/2.

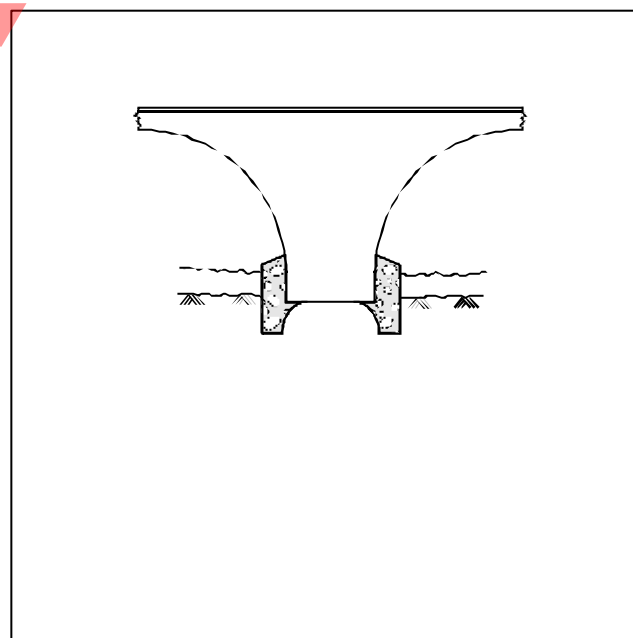
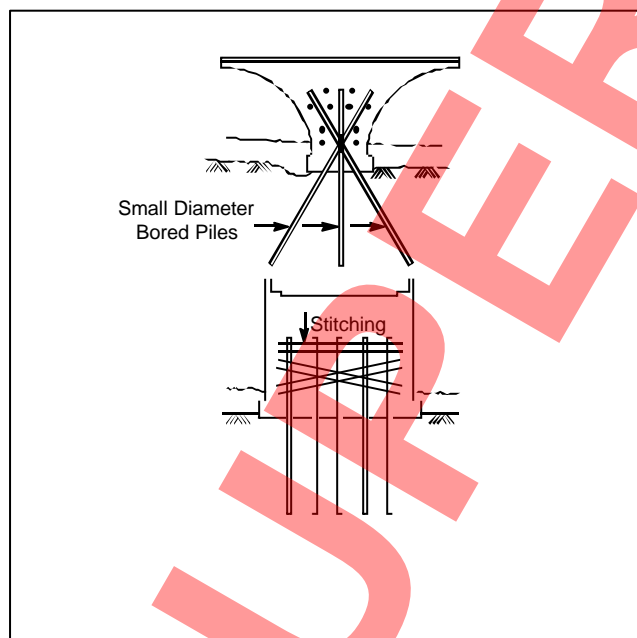

Figure C/1 Small Diameter Bored Piling and Stitching

Figure C/2 Use of Concrete Apron

Arch Barrels

C3.3 The most common means of strengthening an arch barrel is to cover it with a reinforced concrete saddle or relieving arch. The advantage of this method is that it not only strengthens the arch but also improves load distribution and ties together any cracked sections. When using this method care must be taken to ensure that the thrust is transmitted to the abutment and that the abutment is capable of carrying the additional load, Figure C/3.

It is usual to cast the saddle directly onto the existing extrados, thus ensuring composite action. Where no extra stress must be carried by the existing arch then a smooth debonding layer must be introduced. To reduce induced shrinkage stresses the saddle should be thoroughly cured and consideration given to casting segmentally.

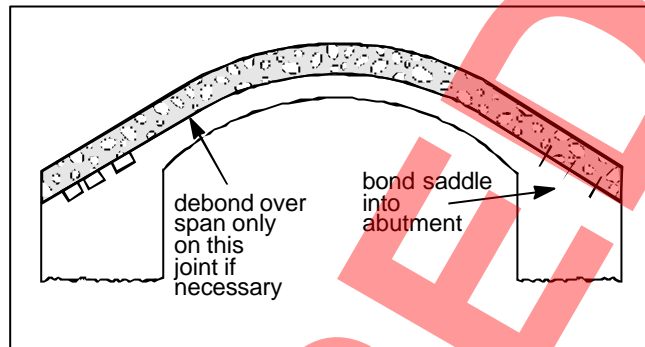

Figure C/3 Concrete Saddle

If extra thrust cannot be accepted by the abutments then a concrete slab may be built taking the necessary support from the abutments, Figure C/4. It should be borne in mind that removal and replacement of fill ought to be carried out with care and uniformity in order that unequal loading of the arch barrel does not occur. The replacement fill should be well compacted free draining material or weak concrete. A waterproof membrane should be applied to the top of the saddle or relieving arch before the fill is replaced.

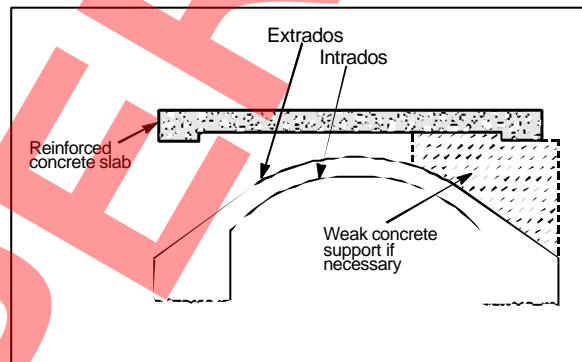

Figure C/4 Concrete Relieving Slabs

Where there is a large depth of fill or where the headroom beneath the bridge is not critical and appearance is not important, it is often economic to place a relieving arch underneath. This may be conveniently provided by sprayed concrete techniques or by placing a corrugated metal or glass reinforced liner within the arch and pumping concrete into the gap between the liner and the existing intrados, Figure C/6.

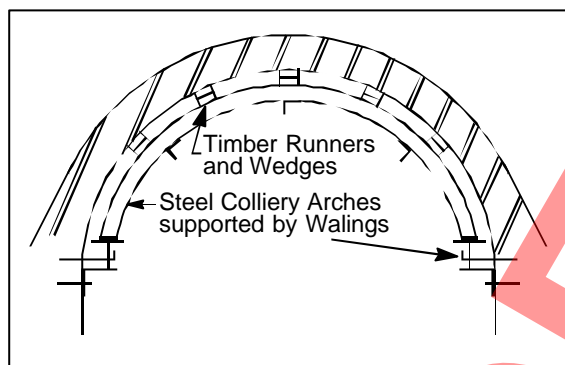

Figure C/5 Use of Colliery Arches

As a temporary measure during the passage of a mining wave, steel colliery arches may be used, supported by walings bolted to the abutments, Figure C/5; bent inverted T or I rolled steel beams may also be used to provide support for the arch.

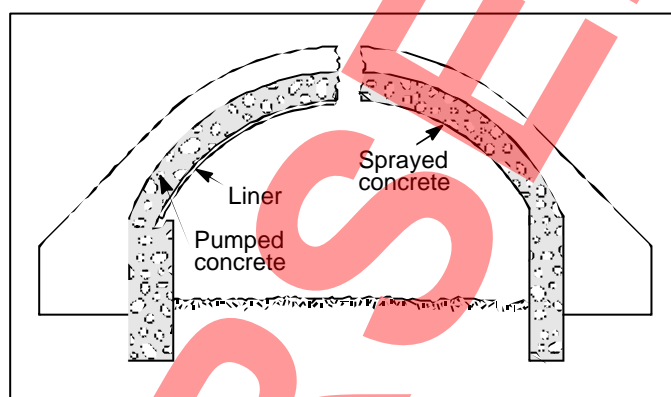

Figure C/6 Strengthening from Underneath the Arch

Spandrel Walls

C3.4 The traditional means of repairing walls that were deforming, tilting or sliding off the barrel was to tie both walls together with rods and large spreader plates on the outside of the bridge. This is unsightly, but has the advantage that it can be carried out without disrupting traffic. Another solution is to expose the walls and backfill them with concrete. If a barrel is being saddled, this is always the most appropriate method. Alternatively, consideration can be given to the use of needling through the spandrel walls.

Road Surfacing

C3.5 Surfacing must be kept in good repair as irregularities cause increased impact loading. Pot holes, lack of camber and cracks allow entry of water. Particular care should be taken to ensure that service trenches are properly backfilled and the surfacing resealed.

Cast Iron Arches

C3.6 Cast iron is a brittle, unpredictable material and extreme care must be exercised when removing existing decks. Whilst welding can be carried out it is difficult and the results are often of doubtful integrity and are best restricted to non-structural members such as decorative parapets, where metal stitching techniques may also be used.

Major strengthening is usually achieved by casting members into reinforced concrete or by placing additional steel or reinforced concrete ribs between the existing cast iron members.

Widening of Masonry Arches

C3.7 There is often a need to widen old arch bridges to accommodate growth in traffic volumes. To produce the most pleasing appearance an arch bridge should be widened using similar materials and to the same profile as the existing structure. However, as reinforced concrete is much cheaper than masonry it is common practice to widen the barrel in concrete and to reserve the use of masonry for the spandrels and outer ring of voussoirs. A vertical joint between the extension and old bridge should be provided to accommodate relative settlements of foundations unless they are founded on rock or piles. This gives rise to a problem (particularly with narrow extensions), as the thrust through the fill will try to push the extension away from the original structure and open up the joint. It may therefore be necessary to tie the two together in a manner which will still permit vertical settlement to occur. An alternative solution is to use weak concrete as the filling material.

Less pleasing in appearance are extensions consisting of steel or concrete beams with spans equal to those of the existing bridge. The support for the beams may consist of either cantilevers at the piers or abutments, an independent extension of the pier or abutment, or, in the case of piers, an extension of the cutwaters, Figure C/7b. A more sympathetic method of widening often used is that shown in Figure C/8. This consists of a concrete slab laid across the top of the bridge with cantilevers on both sides. However, due to the possibility of overloading the edges of the arch, the cantilevers should not have excessive length and should preferably carry only footways.

It is often necessary to add splayed approaches to bridges situated near road junctions, and this may be achieved by the method shown in Figure C/9. Experience has shown that steel beams are very difficult to maintain in this situation and concrete beams are preferred.

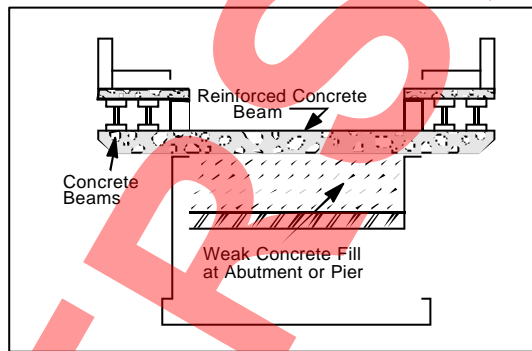

Figure C/7a Widening with Cantilever Beams at Supports

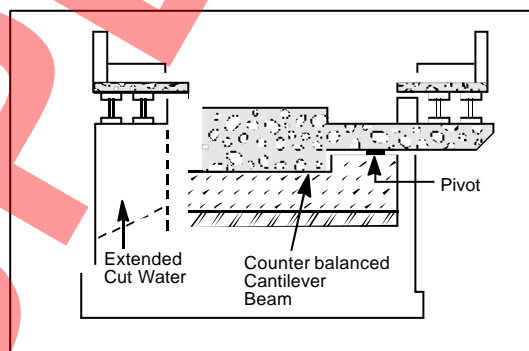

Figure C/7b Widening with Extension of Cutwater

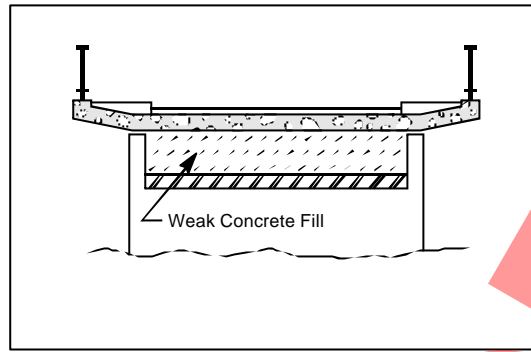

Figure C/8 Cantilever Slab

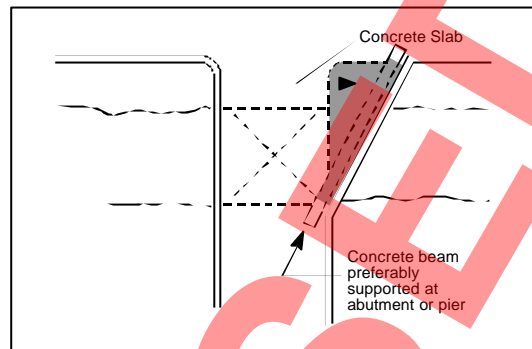

Figure C/9 Splayed Approach

In all cases, care must be taken to avoid overloading the edge of the arch barrel either directly or through the spandrel wall as this may be avoided by one of the solutions shown in Figure C/10.

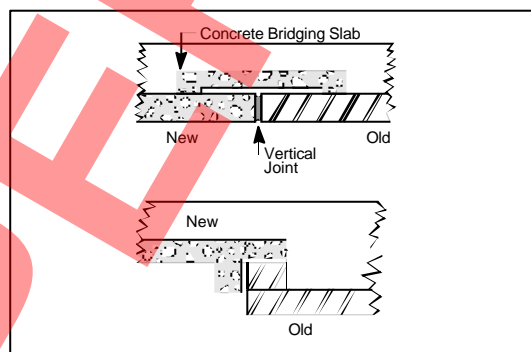

Figure C/10 Details Avoiding Overload at Edge of Old Arch

Beam and Slab Bridges

Masonry Slab

C3.8 Decks formed from stone slabs resting on cast iron or wrought iron beams exist in some parts of the country. In the majority of cases the treatment of these consists of completely renewing the deck using modern materials.

Beam and Slab

C3.9 Reinforced concrete beam and slab bridges are a fairly modern innovation and few were constructed prior to 1922. An inherent problem with many early reinforced concrete bridges is the variable and often low quality of the

Downloaded from https://www.standardsforhighways.co.uk on 06-May-2026, BA 16/97 Amendment No. 2, published: Nov-2001

concrete used and the lack of cover to the reinforcement. Deterioration is often caused by corrosion of the reinforcement and the only remedy is to cut back the concrete behind the reinforcement and repair in accordance with BD 27 (DMRB 3.3).

Steel Structures

C3.10 Many of the early steel structures are reaching the end of their economic lives. Although fatigue is unlikely to be a significant problem, corrosion may be extensive. If the deck has not been waterproofed, serious consideration should be given to providing a waterproofing system, particularly if a susceptible area of corrosion is immediately beneath or behind saturated surfacing materials. The need for the installation of an effective drainage system should also be determined.

Steel structures should be painted at regular intervals with a good paint system (see BD 35 (DMRB 2.4.1) and BA 27 (DMRB 2.4.2)) to protect against corrosion. Care should be taken to ensure that painting systems are not hiding areas of corrosion, slack or corroded rivets. Where corrosion is found it should be removed and if necessary new parent material added. The causes of corrosion should be removed whenever possible.

In many old steel structures, additional structural elements can be added without detracting from the appearance of the structure and, in exceptional cases, the complete deck structure may be renewed using modern materials whilst retaining the original parapet and side details. Prestressing cables and bars can be considered for strengthening provided that they are adequately protected against corrosion.

Accident Repair

General

C3.11 The increased incidents of impact by high loads is a serious problem. Few footbridges survive such an impact and the damage to larger bridges is often severe. Where a bridge has been damaged, assessment of its condition will be necessary.

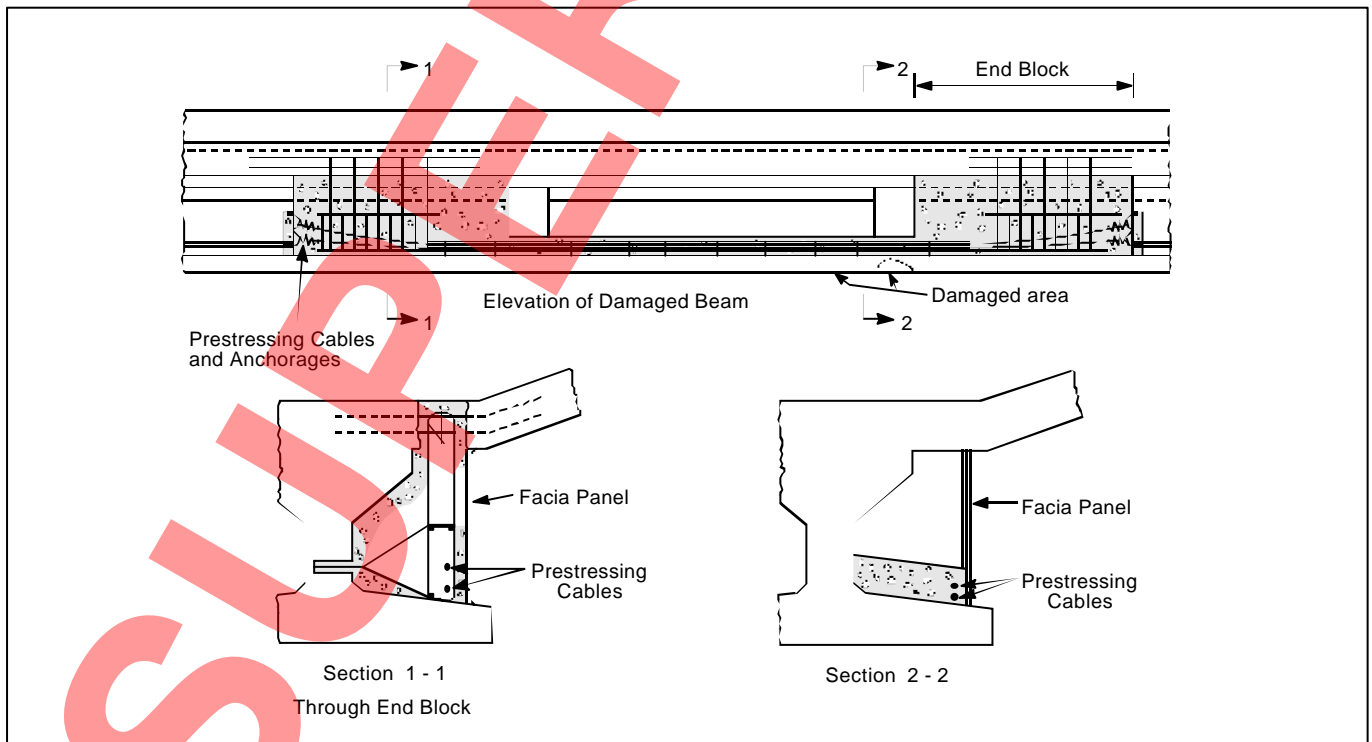

Figure C/11 Prestressed Edge Beam Repair

Treatment of bridges damaged by vehicular impact may differ from the repair needs and techniques associated with older deteriorating structures. Low bridges of light construction are particularly vulnerable to displacement. Steel members can usually be repaired and local damage to concrete can usually be made good. But major damage to a concrete bridge, especially if prestressed, often requires replacement of at least the edge beam.

Repair of Prestressed Beams

C3.12 Pieces of concrete are often broken off the bottom flange of prestressed edge beams from vehicular impact and some of the prestressing cables or prestressing strands can be severed.

If the damage is contained within the immediate area of the impact, repairs may be practical. A typical solution for the repair of severed prestressing wires is shown in Figure C/11. Integrity of the repair may be ensured by cutting slots through the deck slab, care being taken to conserve the reinforcement passing through the slots. End blocks to supplementary prestressing cables may be cast behind the existing transverse diaphragms and it is good practice to ensure good bonding between the new and existing concrete.

When the damage resulting from vehicular impact is not contained over a small area, and where damage to the edge beam web has occurred, the most economical method of repair may prove to be the replacement of the complete edge beam. Alternatively, consideration may be given to the bonding of steel plates to the deck soffit.

Repair of Supports

C3.13 Vehicular impact may also result in severe damage to the support structure, including the formation of plastic hinges. One method of repair which has proved successful is illustrated in Figure C/12.

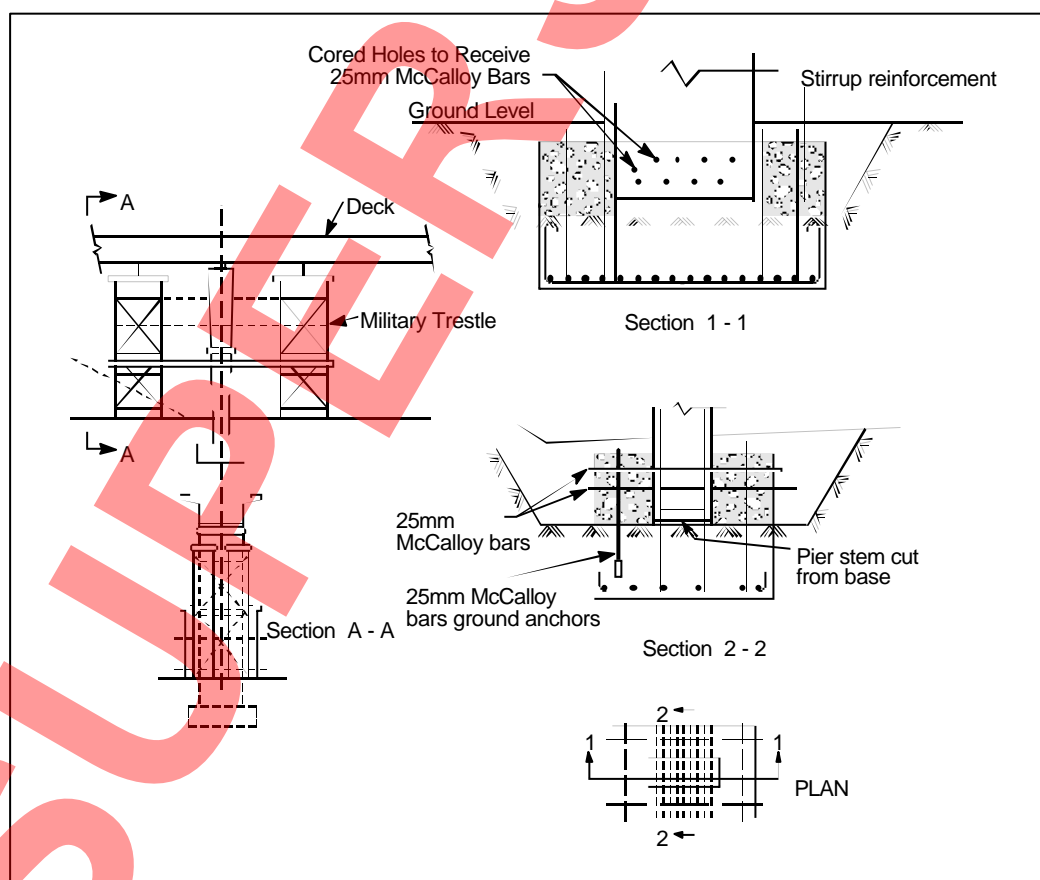

Figure C/12 Repair to Damaged Pier at base

Ground Movements and Mining Subsidence

General

C3.14 Mining of coal and other minerals propagates earth movements in the vicinity of the excavated area. These movements, known collectively as subsidence, are three dimensional in nature, any affected point having components of displacement along all three axes of a general Cartesian co-ordinate system. The displacements are imposed on any structure or bridge in the affected zone and may result in damage or even collapse unless adequate safeguards have been made in the original design, or unless the necessary precautions have been subsequently taken. In the past, these effects could usually be tolerated because of the small size of buildings and structures; alternatively, the flexibility of the old mining methods enabled extraction operations to be excluded from the appropriate areas. Today, the demand for energy and the modern mining methods that have been developed to enhance output make restrictions on the extraction of coal under a particular bridge prohibitively expensive. In addition, modern mining methods can cause settlements up to 1m and ground strains of 1 per cent; these ground disturbances can cause serious damage to any structure not initially designed to withstand them.

The majority of bridges were built before the introduction of modern mining techniques and no structural precautions were taken during their construction to cater for large imposed differential ground movements. Once the problem was recognised in the late 1950s, two main approaches were developed to provide safeguards against the effects of mining subsidence.

One solution is to design the structure to be sufficiently strong to sustain the stresses caused by the imposed displacements so that it can ride the subsidence movement. Alternatively, the bridge can be made flexible by being built up in a series of articulated parts. Mining movement and its effects can be assessed using BD 10 (DMRB 1.3).

Bridges Not Catering for Mining Subsidence

C3.15 Bridges are intimately connected to the ground through their sub-structure and in some cases their overall stability is dependent upon the thrust from supporting abutments. The inevitable consequence of this high degree of soil/structure interaction is that any ground strains are imparted directly to the foundation and sub-structure of the bridge. In turn, these strains are passed on to the deck to a greater or lesser degree, dependent upon the method of articulation.

With some bridge forms such as an arch there is no realistic division between the sub-structure and the super-structure and these types are particularly vulnerable to mining movements. This is because, although arches can withstand some differential settlement and spread of foundations, the strains associated with mining are often greatly in excess of the tolerance that the structure will accommodate. Subsidence damage to arch bridges is therefore often severe, requiring complete reconstruction.

Two major forms of damage to girder bridges or beam and slab bridges are that the abutments could move apart sufficiently to cause the deck to collapse between the abutments, or that the abutments could move together, causing the deck to jam against the curtain walls. The former mode of failure is unlikely to occur, unless the articulation system or bearing plinth has been designed to unusually close tolerances. On the other hand, compression damage is to be expected. Depending upon the relative strength of the deck and the abutment, one or both of these elements may be severely damaged.

In areas of weak subsoil, piled foundations are common. This type of foundation is particularly susceptible to mining subsidence because differential vertical movement can withdraw end support, disrupt material within the pile group block, and cause shear failure of certain pile types.

Damage to the bridge drainage usually occurs during the compression phase of mining subsidence. In addition, bearings are often strained beyond their design capacity.

The major causes of concern with this form of damage, and particularly the compression phase, can be summarised as follows:

- (i) can the deck sustain the tensile and compressive forces imposed or will the deck collapse?
- (ii) even if the deck can sustain the compressive forces, will some elements of the deck ride up out of the road surface creating a hazard to the bridge user?
- (iii) will the movements cause localised overstress and failure in the deck or sub-structure?
- (iv) if the bridge is supported on piles will the mining movements cause them to fracture?
- (v) can the super-structure or sub-structure sustain the torsion caused during the mining?

If there is some doubt concerning the ability of the structure to withstand the mining without collapse, then precautionary action must be taken. In the case of arch bridges this could lead to a decision to demolish the structure prior to mining and to reconstruct a new bridge designed to cater for the subsidence. Alternatively, some assistance to the arch in the form of colliery arches supporting the intrados can be constructed.

The construction of temporary compression trenches immediately behind the abutments can prevent beam and slab or girder decks being crushed as the sides of the cutting close up. These trenches are covered in steel plate to retain traffic flow.

The ability of prestressed decks to sustain the additional forces caused by mining movements without serious damage is doubtful and preventive action prior to mining is necessary. In the case of footbridges, damage may be avoided by lifting the deck off its bearings and supporting it above the ground during the passage of the mining. In the case of larger bridges, this is not possible. The cost of dismantling a bridge can be high and disruption to traffic considerable. In some instances the nature of the bridge is such that temporary dismantling is impossible. In these circumstances it is possible, and sometimes prudent, to construct a separate temporary bridge adjacent to or over the affected structure prior to the mining in order to retain the traffic route should the original bridge sustain severe damage. The cost of a compromise of this magnitude is very high, but may be justified because of the immense costs and disruption to industry which would be incurred if the bridge were to fail.

Bridges Designed to Cater for Mining Subsidence

C3.16 Even when a bridge has been specifically designed for mining subsidence, maintenance is required. In some instances the bridge may sustain secondary damage such as crushing of some part of the drainage system or the buckling of metal parapets. Alternatively, it may be that the final orientation of the bridge, once the mining has passed, will need adjustment by means of jacking to return it to an optimum configuration. If the bridge has been designed to accommodate the movements and the design has proved successful, then maintenance of this nature will be minor. Maintenance would be limited to changing the bearings, replacing drainage pipes and repairing movement joints. Damage to the road pavement adjacent to the bridge should be repaired to reduce the effect of vehicular impact loading.

ANNEX D

DEFECTS IN ARCH BRIDGES

Introduction

This annex contains illustrations of the typical defects which are found in the superstructure of masonry arch bridges, together with some comments on their significance. Section 1 deals with defects which affect the arch barrel, while Section 2 deals mainly with defects which affect other parts of the bridge, such as spandrel and wing walls. References to the appropriate clauses in this Advice Note are given in brackets.

SUPERSEDED

Annex D

Section 1

This section deals with defects which affect the stability and load carrying capacity of the arch barrel and which must be assessed in order to arrive at a suitable condition factor for the arch in question (3.21). These defects are mainly concerned with the shape of the arch and the presence of longitudinal, transverse or diagonal cracking; there may be other defects present but these are taken into account when deriving Material Factors (3.13 to 3.15) and/or Joint Factors (3.16) or when determining the thickness of the arch barrel to be assumed for assessment (3.5 to 3.9). Comments on the condition of each arch and the significance of the defects are given, together with suggested values for the Condition Factors.

SUPERSEDED



Plate 1a Elevation



Plate 1b View of Soffit

Plate 1 The arch shape is good, although there is a slight deformation at the quarter point. There are cracks in a few individual stones but these are not significant. There is also some gouging of the stones caused by passing river traffic.

Suggested Condition Factor: 0.9



Plate 2a Elevation



Plate 2b View of Soffit

Plate 2 The arch shape is good and the brickwork in good condition. There are very slight local deformations but no significant cracking. The dampness is not considered significant.

Suggested Condition Factor: 0.9



Plate 3a Elevation



Plate 3b View of Soffit

Plate 3 The arch shape is generally good, although it is slightly deformed in places. There are some short longitudinal cracks in the Voussoirs, mainly towards the edges of the arch. The repairs to the barrel have been well executed.

Suggested Condition Factor: 0.7



Plate 4a Elevation



Plate 4b View of Soffit

Plate 4 The arch shape is good, but there is severe longitudinal cracking towards the outer areas of the arch barrel.

Suggested Condition Factor: 0.5



Plate 5a General View of Soffit



Plate 5b Close-up of Soffit

Plate 5 The arch shape is good. There are severe longitudinal cracks covering most of the barrel. These are very wide at the edges.

Suggested Condition Factor: 0.3



Plate 6 This shows an arch which has become grossly deformed and flattened in shape. The MEXE method would not be suitable for assessing its carrying capacity and instead it should be assessed from first principles.



Plate 7 This shows a localised deformation of an arch which would perhaps reduce its Condition Factor by 0.1.

Section 2

This section illustrates various defects which, while not affecting the load carrying capacity of the arch barrel, may nevertheless affect the carrying capacity of the structure by affecting the stability of the road surface. These defects are concerned mainly with spandrel and parapet walls and wing walls. Some other localised defects are also illustrated.

SUPERSEDED



Plate 8 This illustrates the radial displacement of individual stones. In this particular case the assumed thickness of the arch barrel was adjusted to take account of the displacement.



Plate 9 This illustrates the movement of spandrel walls.

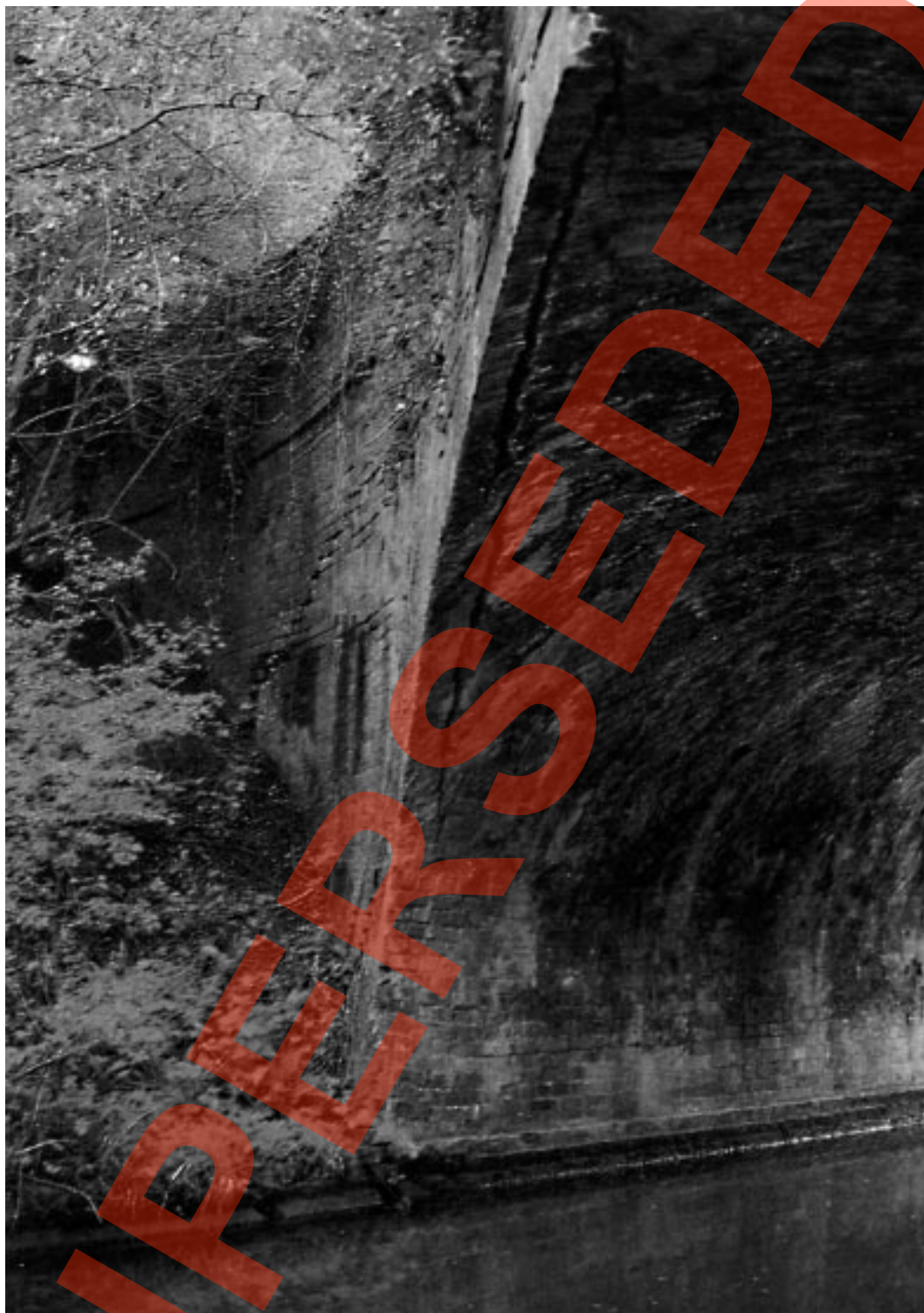

Plate 10 This shows the separation of the spandrel wall from the arch and movement of the wing wall.



Plate 11 This shows cracking of the spandrel/parapet walls which suggest a flexible arch barrel.

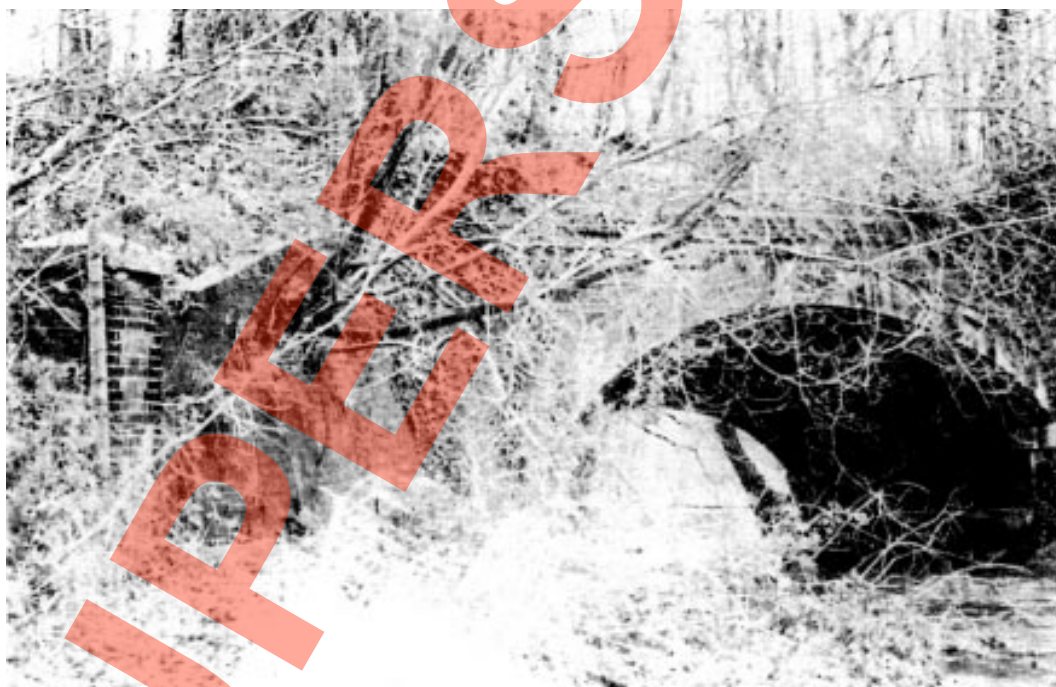

Plate 12 This shows vegetation growing from the faces of the bridge and wing walls; this vegetation should be cut back before it has a chance to damage the brickwork.

ANNEX E

COMPARISON OF MASONRY ARCH BRIDGE ASSESSMENT METHODS

E1. Bridges Engineering Division of the Highways Agency has carried out an exercise of comparing the results from three masonry arch assessment methods with the results of ten full scale tests carried out by the Transport Research Laboratory. The bridges used for the tests, which have been summarised by J Page (10.2.8), were carefully selected to represent as far as possible the full range of commonly encountered highway bridges. The main parameter values of these test bridges are given in Table E/1. Of the ten bridges, the Dundee and Bolton bridges were full scale laboratory models and the Barlae, Bargower and Preston bridges had skew angles of 29, 16 and 17 degrees respectively.

E2. The three assessment methods considered were the mechanism method (computer program ARCHIE), developed by the University of Dundee (10.2.9), the Castigliano elastic method (computer package CTAP), developed by the University of Wales College of Cardiff (10.2.5), and a computer version of the Pippard/MEXE method, developed by Bridges Engineering Division, HA, DOT. For the last method, the results have been obtained using the frame analysis program MINIPONT as described in detail in 4.1-4.12. In a further TRL comparison, referred to in paragraph 4, another mechanism program ASSARC, developed by Structural Survey Partnership, was also considered. At a later stage, results from two other programs, ARCH, a "mechanism" program developed by Cascade Software Limited and MAFEA, a finite element program (10.2.10) developed jointly by British Rail Research and Nottingham University, were also submitted.

E3. The comparisons of results are shown in Table E/2 and Figures E/1 to E/5. In the Figures, the load capacities of the bridges from each of the assessment methods are shown as proportions of the test failure load. The results are plotted against the span to arch thickness ratio for each bridge. The comparison results from all the programs, apart from the Cardiff program CTAP, take into account the crushing strength of the masonry of the ten bridges. The results from the programs other than CTAP have also incorporated the Condition Factors F_{cM} determined by TRL for the bridges prior to testing. The CTAP results have taken into account some of the cracks, etc noted but have ignored other signs which may have contributed to the F_{cM} factors.

E4. In order to examine the numerical accuracy of the methods, a series of two-dimensional plane-stress analyses of the ten bridges was carried out using the finite element computer program SAFE in the course of a TRL extramural contract. The following observations can be made from the results of these analyses.

E5. In the finite element analyses the structures were idealised as arches fixed at the springings. At any live load level the parts of any cross section with principal tensile stress were eliminated progressively until only compressive stresses were left. The surrounding fill, for the first set of analyses, was idealised as a two-dimensional elastic medium with a realistic modulus of elasticity, the soil response being linear elastic without any ultimate failure limit. In a further set of analyses, the Mohr-Coulomb soil properties were used, making it possible to take account of the fill to yield or failure.

E6. The SAFE analysis with linear elastic soil gave load-deflection and load-stress plots which were almost linear at loads up to the test failure loads. This indicates that adjusting the modelling to remove tension in the arch is not enough on its own to stimulate failure. Additional effects must be modelled such as material crushing or passive yielding of the soil. The deflections were found to be very small compared to the overall geometries of the arches; hence large-deflection effects are unlikely to significantly influence failure. This has been confirmed by work done in BE Division and at Nottingham University.

E7. With the fill of the SAFE analysis modelled as a Mohr-Coulomb soil with $c=0$, $\phi=45^\circ$, the analysis showed some gradual curvature indicating progressive soil yield starting at loads less than half the test failure load, but there was no marked increase to indicate incipient failure under loads taken up to the test failure load (see Figures E/6 and E/7 for the Dundee and Bridgemill bridges). From this it would appear that soil failure may not be the cause of arch failure in these tests.

E8. The Pippard/MEXE method is an approximate method since it does not consider crack formation, ie it allows tension to develop in the arch ring. Nevertheless, as can be seen from Figure E/8, except for two bridges, its predicted compressive stresses at the extrados of the third hinge point (ie under the load) are consistent with those from the no-tension analysis using SAFE. As compressive stress failure at the third hinge point is used as the ultimate load criterion, the Pippard/MEXE method will over-estimate load capacity by up to 25 per cent. However, if for this method, as recommended earlier, the characteristic compressive strength f_c is used instead of $1.2f_c$ recommended by Hendry for triangular stress blocks, as the ultimate fibre stress (see references in BD 21 (DMRB 3.4)), this over-estimation should be eliminated. The plane-stress finite element analyses also show that the compressive fibre stresses at the critical sections increase almost proportionately with the applied live load. Furthermore, it has been noted from work done in BE Division and at Nottingham University that the collapse of the arch is immediately preceded by crushing failure under the applied load, ie at the third hinge position. Thus, although it is approximate in its idealisation, the Pippard/MEXE method is likely to give reasonable estimates of the ultimate load capacity. However, since the load capacity calculated by this method is almost directly proportional to the compressive strength of the masonry, it is considered prudent that the masonry strength used for assessment should have an upper limit of 12 N/mm^2 . The results at Figure E/3 were obtained using masonry compressive strengths determined to the above criteria.

E9. The Cardiff program analyses the arch by eliminating the tensile areas of the cross-section. The compressive strength of the masonry is not considered in the analysis. It models the reaction between the fill and the arch with horizontal springs which yield at active and passive limits. These are not able to model directly either the true two dimensional elastic response of the fill or the progressive yield which occurs in a granular material. The spring parameters are derived from the fill parameters using a simplified method which fits the results from the test bridges. In this respect the program is empirical.

E10. It can be seen from Figures E/6 and E/7 that CTAP results are significantly different from the SAFE results. For this comparison, the soil was allowed to yield and large deflection effects, if any, were eliminated.

E11. The mechanism method can work only when all variable loads and reactions are mutually proportional and their proportionality is known or determinate. This is because only one unknown load parameter can be solved for by using this method. If, for example, the surrounding soil acts only as a dead load, the method will be valid. However, the SAFE analyses as well as evidence from tests where soil pressures have been monitored indicate that the passive soil resistance to the deformation of the arch barrel into the fill, which is an unknown parameter unless an elastic analysis is performed, increases with the applied live load. There has also been no indication that this passive resistance reaches a maximum limit before the arches collapse. Therefore, any attempt to use the mechanism method by adopting a fixed soil pressure configuration, as is the case with the three mechanism programs, will give load capacities only pertinent to that pressure configuration which may or may not be the correct distribution at failure. Caution, therefore needs to be applied in using the mechanism method based programs.

E12. To summarise, an attempt has been made in this exercise to compare the collapse loads from ten tests on redundant bridges and full-scale models with those using a number of computer programs. In drawing any conclusions from these comparisons it should be noted that many of these bridges had individual features such as internal spandrel walls and haunching near the springings which no two-dimensional theoretical method can adequately cater for. Contributions to the strengths of the arches from such features have mostly been ignored in the calculations presented here. In addition, many of the parameters used in the calculations have been based on assumptions as they could not be determined from the test details.

E13. As far as the theoretical implications of the various methods are concerned, an attempt has been made to compare significant results from the Pippard/MEXE method and CTAP with those from the plane-stress finite element analyses using SAFE. Since MAFEA uses similar analysis procedures including a similar soil model to CTAP, the observations made may also be pertinent to this program. The validity of the mechanism method has also been examined in the light of the SAFE results.

E14. Based on the above-mentioned comparison exercise, the following conclusions can be made about the computer programs available at present regarding their inherent methodologies:

- (i) all the methods seem to give reasonably safe estimates of collapse loads;
- (ii) the Pippard/MEXE method, despite ignoring the lack of tensile capacity in masonry, can give reliable results;
- (iii) the CTAP results do not agree with those from the corresponding SAFE analyses which, being two-dimensional plane-stress finite element analyses using Mohr-Coulomb soil, may be assumed to be more precise. As MAFEA uses a similar analysis procedure to CTAP, including a similar soil model, this observation may also be pertinent to that program. MAFEA is however more comprehensive than CTAP in that it incorporates material crushing failure in its analysis;
- (iv) the mechanism method, as used by ARCHIE, ARCH and ASSARC, may not be appropriate for arch bridges where soil resistance is important, which has been found to be the case even for relatively flat arches such as Bridgemill. These programs may therefore produce arbitrary results.

TEST BRIDGE	SPAN (m)	RISE (m)	RING THICKNESS (mm)	TOTAL WIDTH (m)	SKEW ANGLE (degrees)
BRIDGEMILL	18.30	2.85	711	8.3	0
BARGOWER	10.36	5.18	588	8.68	16
PRESTON	5.18	1.64	360	8.7	17
PRESTWOOD	6.55	1.43	220	3.6	0
TORKSEY	4.90	1.15	343	7.8	0
SHINAFOOT	6.16	1.19	542	7.03	0
STRATHMASHIE	9.42	2.99	600	5.81	0
BARLAE	9.86	1.69	450	9.8	29
DUNDEEFSM*	4.00	2.00	250	6.0	0
BOLTONFSM*	6.00	1.00	220	6.0	0

* Full Scale Models

Table E/1 Details of Test Bridges

TEST BRIDGE	TEST MAX LOAD	CASTIGLIANO (CTAP)	MECHANISM (ARCHIE)	MEXE/PIPPARD (MINIPONT)	MECHANISM (ARCH)	FINITE ELEMENT (MAFEA)
BRIDGEMILL	310	183	278	245	217	219
BARGOWER	560	601	336	350	411	403
PRESTON	210	184	130	181	73	95
PRESTWOOD	22	0	2	7	6	8
TORKSEY	108	103	91	124	69	91
SHINAFoot	250	268	204	295	205	257
DUNDEE	104	90	23	123	67	96
BOLTON	117	41	39	124	43	52
STRATHMASHIE	132	118	142	112	109	120
BARLAE	290	232	216	320	182	165

Table E/2 Comparison of Failure Loads (Tonnes)

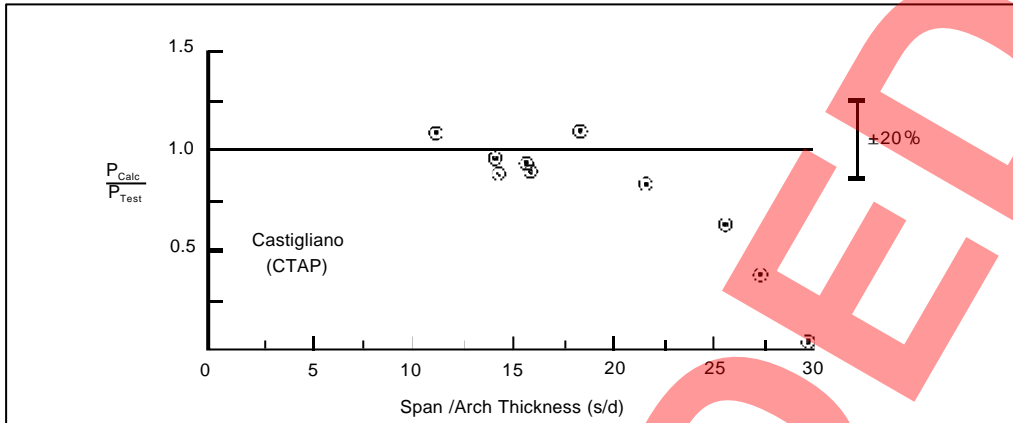

Figure E/1 Failure Load Comparison



Figure E/2 Failure Load Comparison

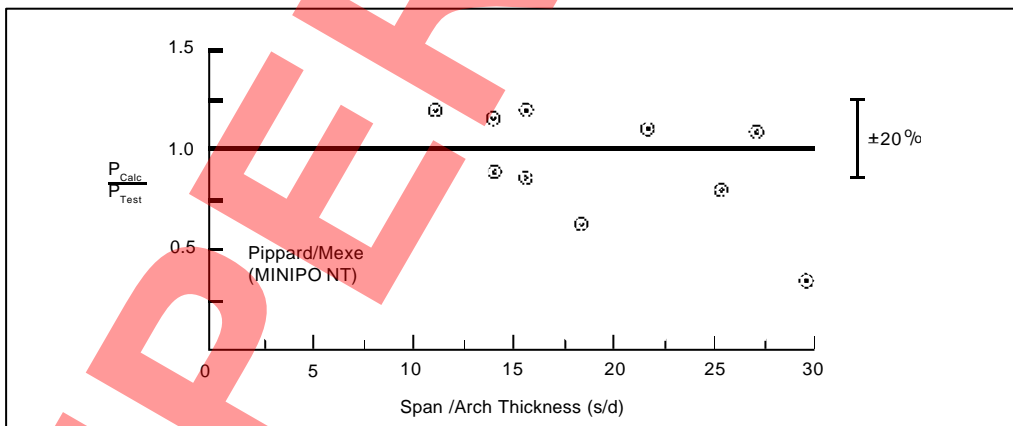

Figure E/3 Failure Load Comparison

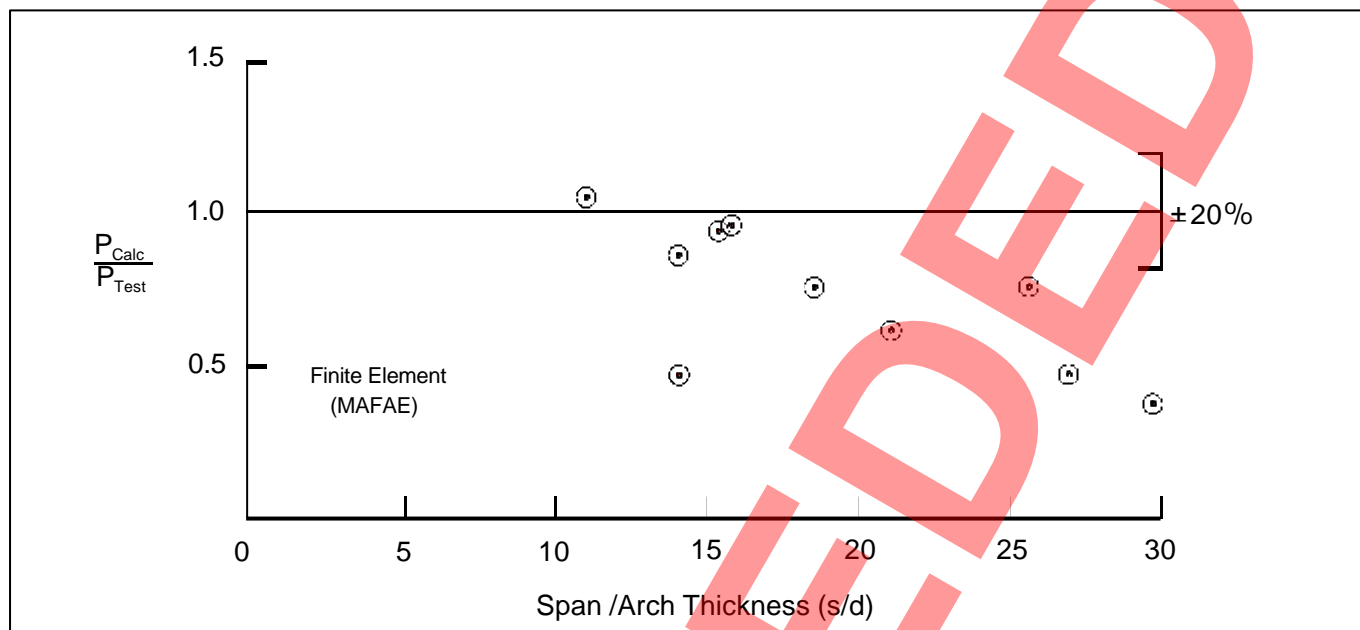
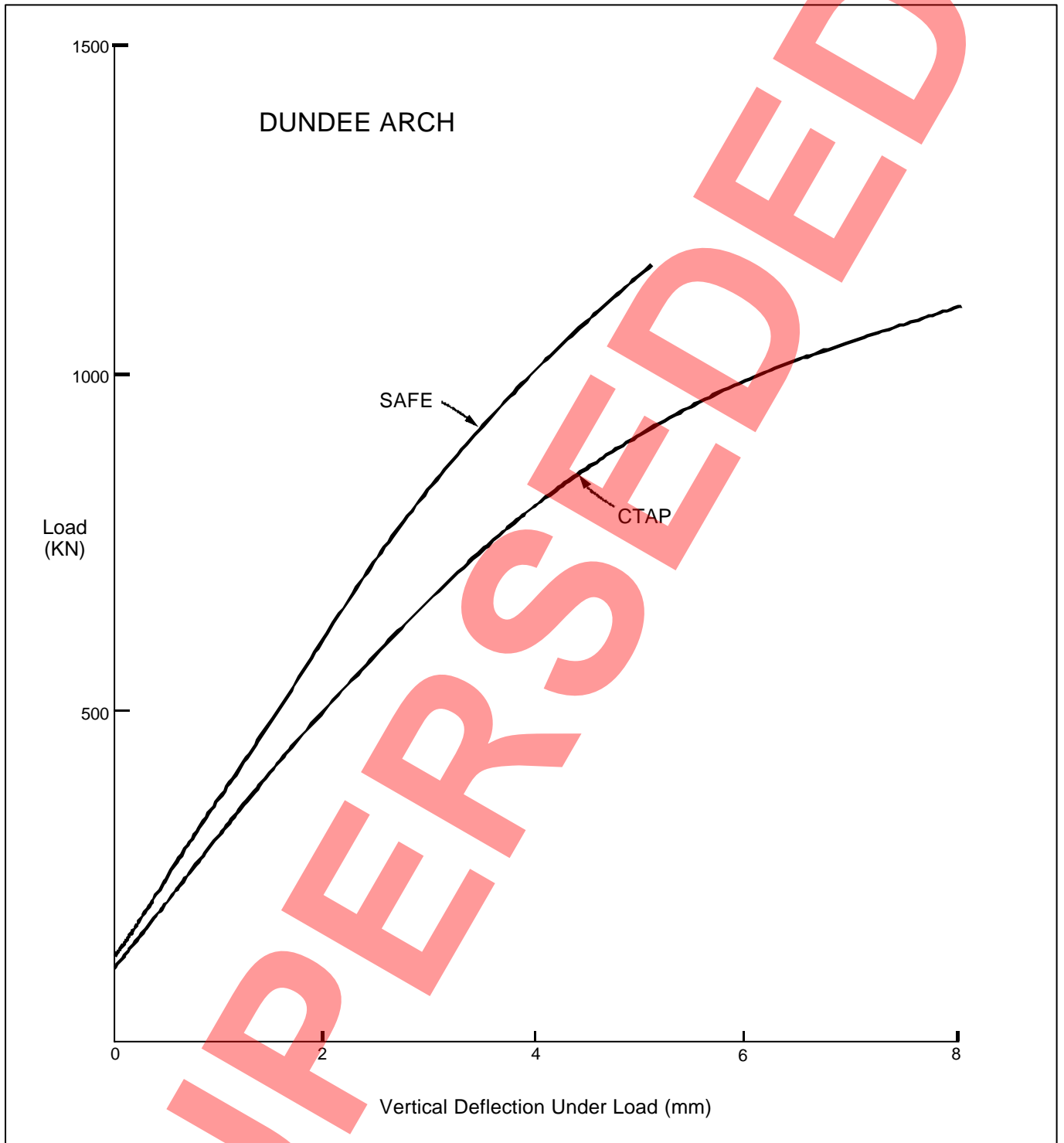

Figure E/4 Failure Load Comparison



Figure E/5 Failure Load Comparison



Comparison of CTAP with SAFE

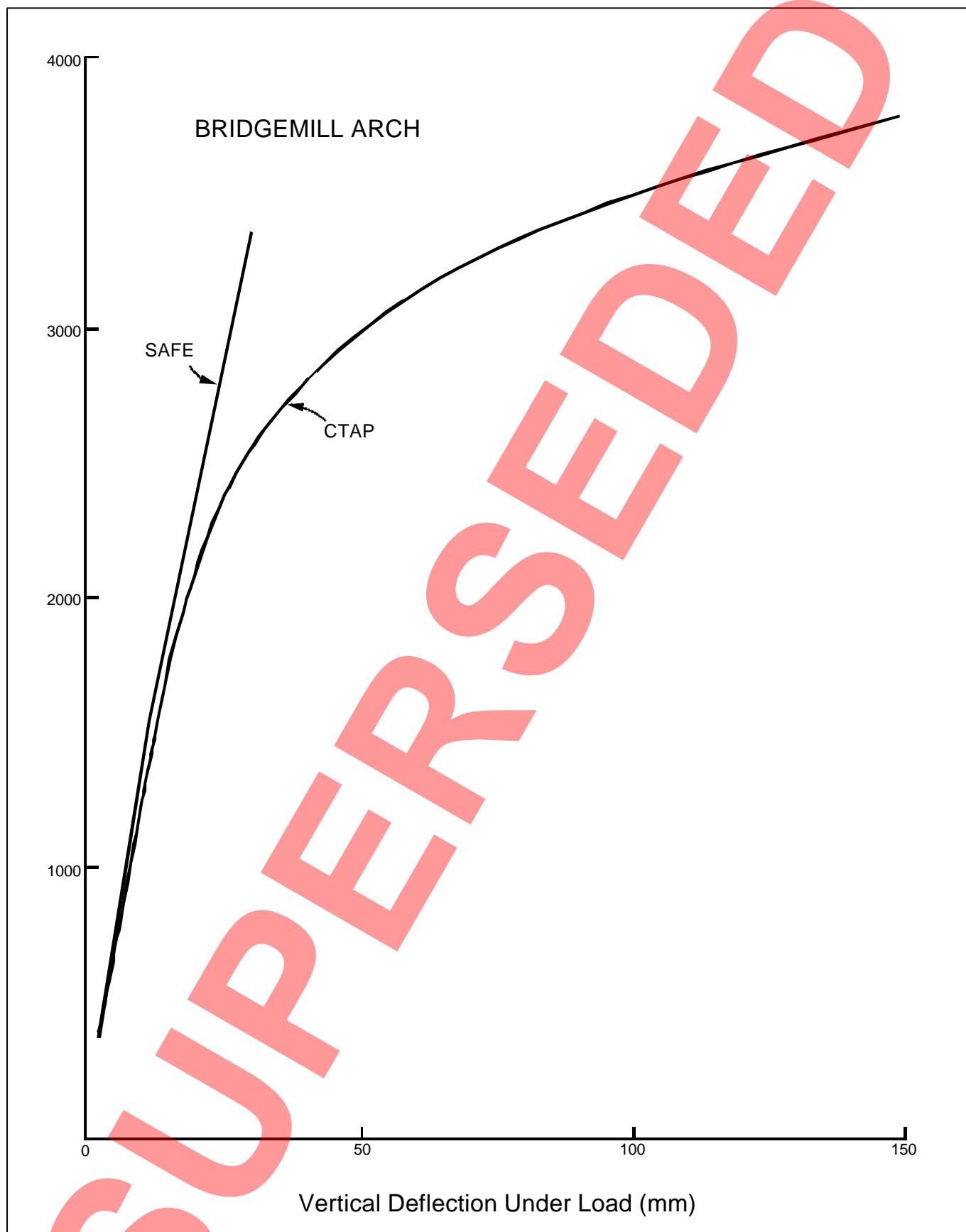

Figure E/7 Comparison of CTAP with SAFE

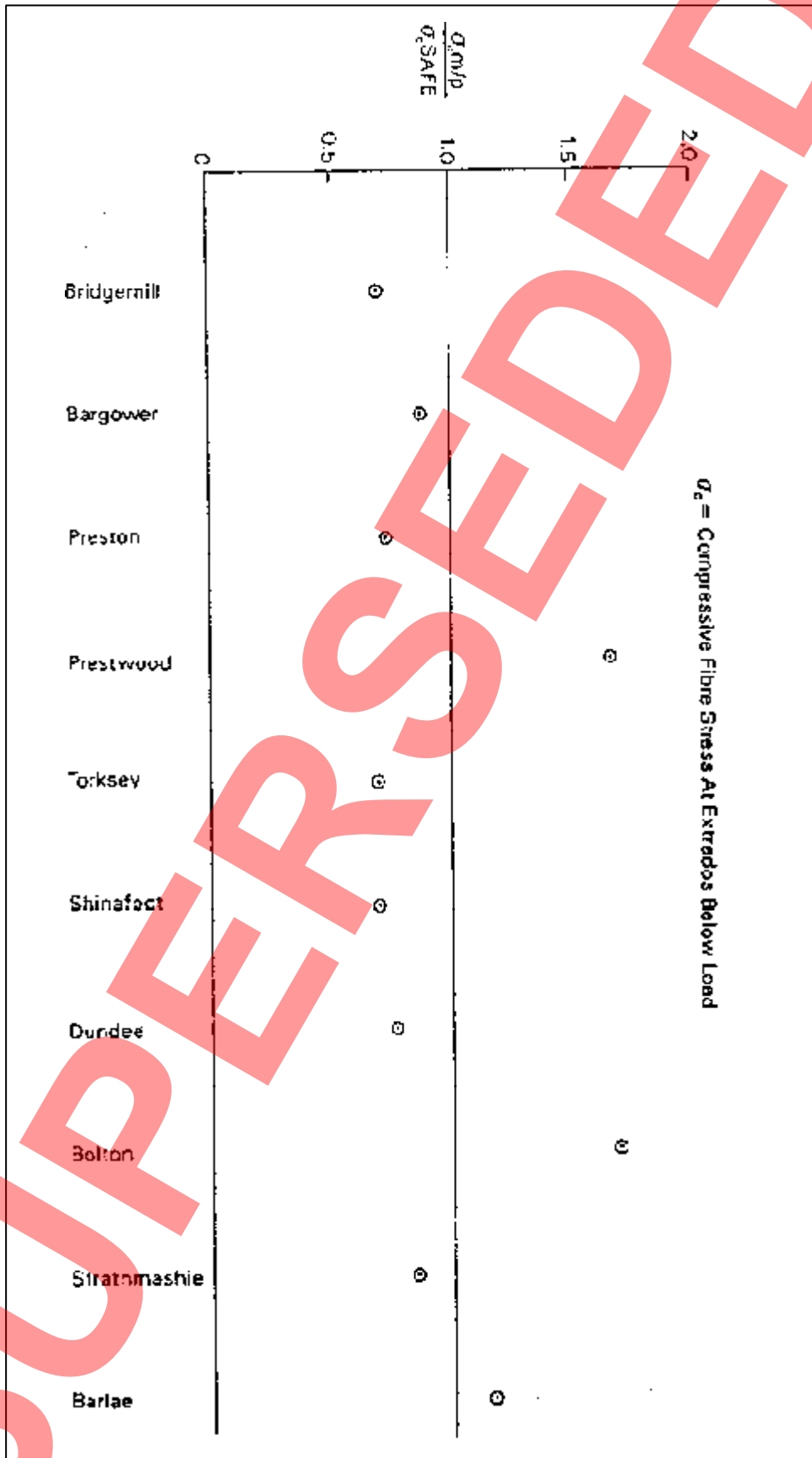

Figure E/8 Comparison of Pippard/MEXE with SAFE

ANNEX F

EXAMPLE OF CALCULATIONS FOR DETERMINING THE LOAD CAPACITY OF A MASONRY ARCH BRIDGE

Introduction

F1.1 The worked example provided in this Annex uses the method of arch assessment given in 4.1 to 4.12. The example illustrates the assessment of a segmental brick arch of span 4.9m, rise 1.154m and arch ring thickness of 0.343m, carrying two lanes of traffic (see Figure 4/1). A 1.0m width of the barrel was analysed separately for dead load and live load of 1.0 t/m (applied at 1/3 span). From the resulting stresses the allowable load/metre was calculated. The line live load was converted to an allowable single axle load and then Figure 3/5 was used to obtain an allowable double axle (bogie) load.

NB: The following calculations are for the 1/3 span section (node 4) where load effects were found to be the greatest.

Section Properties of Arch Ring

F1.2 For 1m width of barrel:

$$\begin{aligned}
 A &= 0.343 \text{ m}^2 \\
 Z &= bd^2/6 \\
 &= 0.343^2/6 \\
 &= 0.019 \text{ m}^3
 \end{aligned}$$

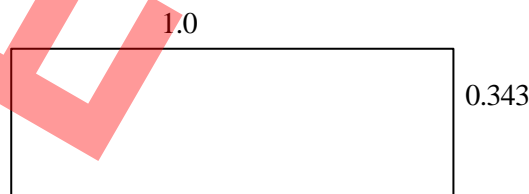

Figure F/1 Barrel Section

Young's Modulus: E	= 14000 N/mm ²	}
		}
Poisson's Ratio: μ	= 0.2	} approximate
		} assumptions
Masonry Strength: f_k	= 5 N/mm ²	}
(See 4.8)		}
Fill (and ring) density	= 2 t/m ³	

Annex F

Dead Load Effects

F1.3 Considering unit width:

From computer analysis:

Axial force	= 3.7 t
Bending moment	= 0.14 tm
γ_{FL} (for fill and arch weight)	= 1.2
Actual width of fill strip	= 1.0 m
Factored axial force $F = 3.7 \times 1.0 \times 1.2$	= 4.44 t
Factored moment $M = 0.14 \times 1.0 \times 1.2$	= 0.17 tm

$$\text{Dead load stresses from axial force } f_{FD} = 4.44/0.343 = \underline{12.9 \text{ t/m}^2}$$

$$\text{Dead load bending stress } f_{MD} = 0.17/0.019 = \underline{8.9 \text{ t/m}^2}$$

$$\text{Total dead load compressive stress} = \underline{21.8 \text{ t/m}^2}$$

Live Load Effects

F1.4 For 1.0t live load/m width of barrel

From computer analysis

Axial force	= 0.71 t
Bending moment	= 0.3 tm

$$\text{Live load stress from axial force } f_{FL} = 0.71/0.343 = \underline{2.1 \text{ t/m}^2}$$

$$\text{Live load bending stress } f_{ML} = 0.3/0.019 = \underline{15.8 \text{ t/m}^2}$$

$$\text{Total live load compressive stress} = \underline{17.9 \text{ t/m}^2}$$

At Ultimate:

Theoretical failure load/m width = N t/m where:

$$N = \frac{f_k - (f_{FD} + f_{MD})}{(f_{FL} + f_{ML})}$$

and f_k = characteristic compressive strength of masonry

$$\text{Hence } N = \frac{500 - 21.8}{17.9}$$

$$\underline{N = 26.7 \text{ t/m}}$$

Theoretical ultimate failure load = (Allowable load. γ_{FL})/(F_j . F_{cM})

F_j . $F_{cM} = 0.51$ (From MEXE assessment)

$$\text{Allowable load} = \frac{26.7 \times 0.51}{3.4} = \underline{4.0 \text{ t/m width}}$$

Allowable axle load

F1.5 If the carriageway is 7.8m wide then 2 lanes of traffic can be accommodated:

Assuming the transverse disposition of wheels and axles is as shown in Figure F/2:

$$\begin{aligned} \text{Effective width} &= 4.3 + h + 1.5 \\ \text{(See BD 21 (DMRB 3.4.3))} &= 5.8 + h \\ h &= 0.35 \text{ m} \\ \text{Hence effective width} &= \underline{6.15 \text{ m}} \end{aligned}$$

If W is the allowable single axle load per vehicle

$$2W = 4.0 \times 6.15$$

$$W = \underline{12.3 \text{ t}}$$

Allowable single axle load = 12.3 t

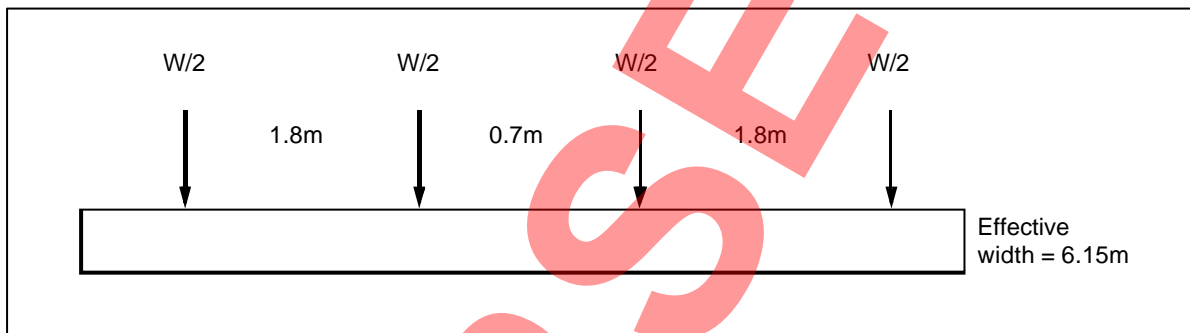

Figure F/2 Effective Width of Wheel Load Dispersal

From Figure 3/5a (no lift-off), the allowable double axle (bogie) axle load can be determined as follows:

$$\text{Allowable double axle load} = \text{allowable single axle load/axle factor for single axle } (A_p)$$

$$\text{For an arch span} = 4.9 \text{ m, } A_p = 1.12$$

$$\text{Allowable double axle load} = 12.3/1.12$$

$$= \underline{10.98 \text{ t (per axle)}}$$

ANNEX G

STUDIES ON THE DEPTH FACTOR AND CONDITION FACTOR, EFFECTS OF SKEW AND STRENGTH OF SADDLE REPAIRED ARCHES

A study [ref 1] has been conducted to investigate appropriate values for the depth factor and the condition factor for use with the Modified MEXE Method. The study was conducted at the University of Nottingham, using finite element programs [ref 2, 3] developed for assessing the behaviour of masonry arch bridges. Based on the computer results, the following guidelines were drawn:

- The recommended depth factor of 0.8 in Table 3/5 for insufficiently filled joints with up to one tenth of the thickness of the arch barrel is close to the average values obtained in the numerical studies. Where joints are insufficiently filled for more than ten percent but less than thirty percent of the barrel thickness, the depth factor may be estimated [ref 4] from:

$$F_d = \left[\frac{d - d_j}{d} \right]^2$$

where d = barrel thickness
and d_j = depth of missing mortar in joint

- Where the longitudinal cracks in the arch barrel are deemed to affect the stability and load carrying capacity of the arch barrel, it has been shown that the problem should be examined based on the exact location of the longitudinal cracks and possible loading conditions. The worst case is that of a heavy wheel load located completely on a narrow barrel section which is separated from the bridge due to longitudinal cracks.
- By reducing the arch barrel thickness at a single nodal position to stimulate a localised lateral crack, it was shown that the effect of a lateral crack depends on its location, depth and loading on the bridge. The recommended condition factors of 0.6 to 0.8 were shown to be reasonable, and the value of 0.8 corresponds to a crack depth of around 30% of the arch barrel thickness.
- By using 8 noded degenerated shell elements to represent the arch barrel it was shown [ref 5] that average load carrying capacity of arch bridges with diagonal cracks ranged from just over 30% to just under 60% of the capacity of a similar bridge without diagonal cracks, thus confirming the recommended values given in 3.21(iii), namely 0.3-0.7.
- Pending a more detailed study involving the complex structural behaviour of the walls and the interactions between spandrel wall and arch barrel it was shown that the recommendation in 3.21(iv) that cracks in the spandrel walls near the quarter point indicate flexibility of the arch barrel over the central half of the span (condition factor of 0.8) is reasonable and conservative.

From similar studies [ref 6, 7], using the same finite element programs [ref. 8, 9], the following guidelines were drawn:

- The studies showed that ring separation in the barrel of the arch bridges can lead to a considerable reduction in load carrying capacity. The following linear expressions may be used for estimating the average reduced load carrying capacity of arch bridges with 4 and 6 separated rings:

$$\begin{aligned} R_{4\text{-rings}} &= 1 - 0.2N \\ R_{6\text{-rings}} &= 1 - 0.146N \end{aligned}$$

where

- $R_{4\text{-rings}}$ = ratio of load capacity (4 separated rings to unseparated barrel)
 $R_{6\text{-rings}}$ = ratio of load capacity (6 separated rings to unseparated barrel) and
 N = number of separated rings

- The numerical studies on the improvement in load carrying capacity of masonry arch bridges due to composite action of concrete saddles or strengthening from underneath (eg using sprayed or pumped concrete) showed that considerable increases in load carrying capacity can be achieved. The increase in strength is dependent on whether the arch barrel can be considered and whether the saddle or spayed concrete is reinforced. However, it was shown that the average increase in strength can be conservatively estimated from:

$$R_{\text{conc}} = 1 + 4t$$

- Where the saddle or spayed concrete is nominally reinforced, the average increase in strength can be estimated from:

$$R_{\text{nominal}} = 1 + 5.5t$$

where

- R_{conc} = ratio of load capacity (concrete without reinforcement)
 R_{nominal} = ratio of load capacity (concrete with nominal reinforcement)
and t = ratio of saddle strengthening thickness to barrel thickness

- The studies, using degenerated shell elements, on skew arch bridges where the span parallel to the axis of the arch (ie skew span) and bridge widths are kept constant showed that the load carrying capacity increases in general as the skew angle of the arch bridge increases from 0° up to 30°. In general, the most severe load case is that of a line load acting parallel to the bridge abutment. The increase in load carrying capacity is in part a reflection of the increase in the loaded length due to the increase in skew angle. The average increase in load carrying capacity of a skew bridge over a square bridge with the same span and width can be estimated from:

$$(b/w)^2$$

where b = abutment width and w = bridge width

References

- Gong, N.G. and Choo, B.S., Assessment of masonry arch bridges - effects of some defects in arch rings, Report no. SR94014, Dept of Civil Engineering, University of Nottingham, Sept 1994, 109pp.
- Choo, B.S., Coutie, M.G. and Gong, N.G., Finite Element Analysis of Masonry Arch Bridges using Tapered Beam Elements, Proceedings of Institution of Civil Engineers, Part 2, 91, paper no. 9774, December 1991, pp. 755-770.
- Gong, N.G., Finite element analysis of masonry arch bridges, PhD, Thesis, University of Nottingham, 1992.
- Choo B.S., and Gong N.G., "An assessment of the Joint Factor as used in the modified MEXE Method", Proceedings. First ASCE Congress on Computing in Civil Engineering, Washington D.C., 20-22nd June 1994, pp. 704-711.
- Gong N.G., and Choo B.S., "Effects of diagonal cracks on the behaviour of masonry arch bridges", Proceedings, The Centenary Year Bridge Conference, Cardiff, 26-30th September 1994, pp. 205-210.

- 6) Gong, N.G. and Choo, B.S., Assessment of masonry arch bridges - strength of arch bridges with concrete saddles, Report no SR94015, Dept of Civil Engineering, University of Nottingham, Sept 1994, 32pp.
- 7) Gong, N.G. and Choo, B.S., Assessment of masonry arch bridges - effects skew, Report no SR94016, Dept of Civil Engineering, University of Nottingham, Sept 1994, 59pp.
- 8) Choo B.S., Coutie M.G. and Gong N.G, "Finite element analysis of brick arch bridges with multiple ring separation", Proceedings, 6th Canadian Masonry Symposium, Saskatchewan, Canada, June 1992, pp. 789-799.
- 9) Gong N.G. and Choo B.S., "Effect of ring separation in arch bridges". Proceedings, 4th International Conference on Short and Medium Span Bridges, Halifax, Nova Scotia, Canada, 8-11th August 1994, pp. 201-210.

SUPERSEDED

ANNEX H

THE ASSESSMENT OF DRY-STONE RETAINING WALLS

The following guidance on the assessment of dry-stone retaining walls is offered to personnel undertaking this work on behalf of the Highways Agency:

H1. The initial assessment requires a visual inspection and relies on engineering judgement to assess the capacity of dry-stone retaining walls.

H2. The following investigations should take place to support judgement of the load carrying capacity of each wall:

H2.1 Existing records should be trawled in an effort to establish the age of walls.

H2.2 Geological records and site observations should establish the subsoil conditions. A view should be expressed on the likely nature of the retained material supporting the wall foundations.

H2.3 The structure inspection and maintenance records should be scrutinised for evidence of wall stability problems and maintenance details.

H2.4 Traffic flow data should be inspected to establish the existing loads carried by walls in terms of volume traffic and maximum loads carried.

H2.5 'Soft' vegetation should be removed in advance of detailed site inspections and surveys.

H2.6 Detailed visual observations during site inspections and surveys should include:

a. Site survey measurements to establish:

- the size and location of trees and large shrub growth from, and likely to influence, dry-stone walls.
- Wall dimensions including overall and retained heights of walls and height of parapets.
- Wall thicknesses. (Dismantling and excavation behind walls should not be carried out for the initial investigation.)
- The location of drainage outlets, the carriageway, SU apparatus, significant vegetation growth, and the ground slope in front of, and behind, walls.
- The location of any evidence of wall movement, bulging, deformation, adjacent ground movement and carriageway cracking.

b. Identification of the type of stone and the extent of weathering and deterioration.

c. Investigation of wall drainage. Evidence of problems caused by drainage should be recorded, (eg excessive weathering due to drainage outlets and drainage at the wall/subsoil interface causing foundation instability).

Annex H

H3. The assessment report should record the outcome of all of the above investigations. It should also include a section giving recommendations for remedial work, where appropriate.

H3.1 Walls should be split into sections to reflect different remedial work requirements. Consideration should be given to the influence of trees and heavy vegetation on the stability of section walls. Identify trees, etc on non Highway land which may affect the integrity of the walls, and assess the impact of removal of these by landowners.

H3.2 Remedial work items should be itemised and cost estimates provided which identify full work costs.

H3.3 Remedial works should be that work required to enhance the load carrying capacity of walls to enable them to carry dead load, superimposed dead load and full type HA live loads as defined in BD 21 (DMRB 3.4.3). However, if major strengthening or reconstruction are proposed, the design should take account of the load carrying requirements of the route.

H3.4 Report the judgement of the current load carrying capacity of walls based on the Assessment Investigations and confirm that, subject to the execution of the recommended remedial works, the walls can carry the assessment loads or, where major strengthening or reconstruction is to be carried out, the appropriate design loads.

H3.5 The reports should include a copy of the endorsed Approval in Principle, Assessment and Check Certificates and Assessment Report Forms.

H3.6 A report is required for each structure which is separately identified and which falls within the Assessment of Strengthening programme.

H4. Any significant defect found during the course of assessment should be addressed without delay where it may, if unattended, lead to local collapse and loss of support to the highway. Any other sections of wall which require immediate attention should be reported without delay to the Overseeing Organisation.