

**MANUAL OF CONTRACT DOCUMENTS FOR HIGHWAY WORKS  
VOLUME 1 SPECIFICATION FOR HIGHWAY WORKS**

**SERIES 900  
ROAD PAVEMENTS – BITUMINOUS BOUND  
MATERIALS**

Contents		Clause	Title	Page
Clause	Title			
		922	(05/18) Surface Dressing: Design, Application and End Product Performance	23
900	(05/18) General	3		
901	(05/18) Bituminous Mixtures	3		
902	(05/18) Reclaimed Asphalt	5	923 (05/18) Cold Applied Ultra-Thin Surfacing	26
903	(05/18) Placing and Compaction of Bituminous Mixtures	6	924 (05/18) High Friction Surfaces	29
904	(05/18) Hot Rolled Asphalt Base	9	925 (05/18) Testing of Bituminous Mixtures	30
905	(05/18) Hot Rolled Asphalt Binder Course (Recipe Mixtures)	9	926 (05/18) In Situ Recycling: The Repave Process	30
906	(05/18) Dense Base and Binder Course Asphalt Concrete with Paving Grade Bitumen (Recipe Mixtures)	10	927 & 928 (05/18) Not Used	31
907	(05/18) Regulating Course	10	929 (05/18) Dense Base and Binder Course Asphalt Concrete (Design Mixtures)	31
# 908	(07/21) Warm Mix Asphalt	10	930 (05/18) EME2 Base and Binder Course Asphalt Concrete	32
909	(05/18) 6 mm Dense Asphalt Concrete Surface Course	12	931 to 935 (07/19) Not Used	36
910	(05/18) Hot Rolled Asphalt Surface Course (Recipe Mixtures)	12	936 (07/19) Geosynthetics and Steel Meshes: Installation and End Product Performance	36
#911	(05/18) Hot Rolled Asphalt Surface Course (Design Mixtures)	13	937 (05/18) Stone Mastic Asphalt (SMA) Binder Course and Regulating Course	38
912	(05/18) Close Graded Asphalt Concrete Surface Course	13	938 (05/18) Porous Asphalt	40
913	(05/18) Not Used	14	939 to 941 (05/18) Not Used	40
914	(05/18) Fine Graded Asphalt Concrete Surface Course	14	#942 (05/18) Thin Surface Course Systems	40
915	(05/18) Coated Chippings for Application to Hot Rolled Asphalt Surfacing	14	943 (05/18) Hot Rolled Asphalt Surface Course and Binder Course (Performance-Related Design Mixtures)	47
916 & 917	(05/18) Not Used	14	944 (05/18) Not Used	48
918	(05/18) Slurry Surfacing Incorporating Microsurfacing	14	945 (05/18) Weather Conditions for Laying of Bituminous Mixtures	48
919	(05/18) Surface Dressing: Recipe Specification	18	946 (05/18) Local Repairs	49
920	(05/18) Bond Coats, Tack Coats and Other Bituminous Sprays	20	947 (05/18) In Situ Cold Recycled Bound Material	51
921	(05/18) Surface Macrotexture of Bituminous Surface Courses	22	948 (05/18) Ex Situ Cold Recycled Bound Material	59
			949 (05/18) Not Used	65
			950 (05/18) Surface Preservation Systems	65

**MANUAL OF CONTRACT DOCUMENTS FOR HIGHWAY WORKS  
VOLUME 1 SPECIFICATION FOR HIGHWAY WORKS**

Clause	Title	Page
951	(05/18) Torque Bond Test	65
952 & 953	(05/18) Not Used	66
954	(05/18) Method for Laboratory Determination of Interface Properties Using the Modified Leutner Shear Test	66
955	(05/18) Ageing Profile Test Using a Modified Rolling Thin Film Oven Test (MRTFOT)	71
956 & 957	(05/18) Not Used	81
958	(05/18) Modified Binder Storage Stability Test	81

**NATIONAL ALTERATIONS OF THE OVERSEEING ORGANISATIONS OF SCOTLAND, WALES AND NORTHERN IRELAND**

Clause	Title	Page
<b>Scotland</b>		
908TS	(07/21) Warm Mix Asphalt (WMA)	S1
911TS	(07/21) Hot Rolled Asphalt Surface Course (Design Mixtures)	S2
942TS	(07/21) Stone Mastic Asphalt Surface Course (TS2010)	S3F
<b>Wales</b>		
908WG	(07/21) Warm Mix Asphalt (WMA)	W1
911WG	(07/21) Hot Rolled Asphalt Surface Course (Design Mixtures)	W1
942WG	(07/21) Welsh Government Procedure and Advice Guidance (PAG) 112/20 – Stone Mastic Asphalt Specification	W2F
<b>Northern Ireland</b>		
908NI	(07/21) Warm Mix Asphalt (WMA)	N1F

# denotes a Clause or Sample Contract Specific Appendix which has a substitute National Clause or Sample Contract Specific Appendix for one or more of the Overseeing Organisations of Scotland, Wales or Northern Ireland.

# ROAD PAVEMENTS – BITUMINOUS BOUND MATERIALS

## 900 (05/18) General

1 (07/21) This Series is part of the Specification for Highway Works. Whilst this Series is particularly relevant to the subject matter in its title it shall be read in conjunction with the general requirements in Series 000 and 100 and with all other Series relevant to the specification for the particular works to be undertaken.

## 901 (05/18) Bituminous Pavement Mixtures

### (05/18) General

- 1 (07/21) This Clause gives general requirements for production of bituminous mixtures, as well as the properties of the aggregates and bitumen used in plant-produced mixtures. These requirements shall apply to all plant produced bituminous mixtures unless otherwise specified in contract specific Appendix 7/1 or where other requirements are given in specific Clauses in this Series.
- 2 (07/21) Asphalt mix formulations produced and supplied in accordance with BS EN 13108 shall be CE marked.
- 3 (07/21) The Contractor shall submit the Declaration of Performance which demonstrates that the asphalt mix formulation provides the performance required by the specification.

### (05/18) Aggregates for Bituminous Mixtures

- 4 (07/21) Natural, recycled unbound and manufactured (artificial) aggregates shall be clean, hard and durable and comply with BS EN 13043 and be CE marked and have a declared performance which demonstrates that the aggregate meets the requirements of the specification.
- 5 (07/21) Where recycled coarse aggregate or recycled concrete aggregate is used in bituminous mixtures, it shall have been tested in accordance with Clause 710.
- 6 (07/21) The content of other materials (Class X) including wood, plastic and metal shall not exceed 1% by mass.
- 7 (07/21) Reclaimed asphalt shall comply with Clause 902.
- 8 (07/21) The use of aggregate derived as a by-product during the extraction of china clay is permitted. It shall comply with the requirements of this Clause, BS EN 13043 and the examples of the relevant annex of PD 6691.

### (05/18) Crushed Slate Aggregate

- 9 (07/21) The use of crushed slate aggregate is only permitted in base and binder course layers. It shall not be used in surface layers.
- 10 (07/21) Crushed slate aggregate shall comply with the requirements of this Clause, BS EN 13043 and the examples of the relevant annex of PD 6691.
- 11 (07/21) The flakiness category of crushed slate aggregate shall be approved by the Overseeing Organisation.
- 12 (07/21) Mixtures of crushed slate aggregate with coarse aggregate of a different geological type shall not be permitted.

### (05/18) Resistance to Fragmentation (Hardness)

13 (07/21) When tested in accordance with clause 4.2.2 of BS EN 13043 and unless otherwise stated in contract specific Appendix 7/1 the resistance to fragmentation of the coarse aggregates for bituminous mixtures shall meet the following criteria:

- (i)  $\leq LA_{30}$  for natural aggregates and  $\leq LA_{50}$  for blast furnace slag; or

- (ii) for aggregates greater than LA<sub>30</sub> but less than LA<sub>35</sub>, where evidence can be presented to the Overseeing Organisation of previous satisfactory use of the source in asphalt.

(05/18) **Resistance to Freezing and Thawing (Durability)**

**14** (07/21) When required in contract specific Appendix 1/5, the resistance of the coarse aggregate to freezing and thawing shall be declared.

**15** (07/21) The freezing and thawing (soundness) category, as defined in BS EN 13043 clause 4.2.9.2, shall be MS25 unless otherwise specified in contract specific Appendix 7/1.

**16** (07/21) The water absorption value of the coarse aggregate shall be determined in accordance with BS EN 13043 clause 4.2.9.1.

**17** (07/21) If the water absorption value of the coarse aggregate is greater than WA242, the soundness test shall be carried out on the material delivered to site. The requirements for water absorption do not apply to blast furnace slag aggregate.

(05/18) **Cleanliness**

**18** (07/21) Unless otherwise specified in contract specific Appendix 7/1, the proportion of coarse and fine aggregates for bituminous mixtures passing the 0.063 mm test sieve (fines content) shall not exceed the limits stated in BSI PD 6691 Annex B, Annex C and Annex D, when tested in accordance with the washing and sieving method of BS EN 933-1.

(05/18) **Resistance to Polishing and Surface Abrasion**

**19** (07/21) When specified in the appropriate Clause or contract specific Appendix 7/1, the aggregate shall conform to the required declared PSV category in accordance with BS EN 13043 clause 4.2.3 and BSI PD 6682-2 clause 4.3.2.

**20** (07/21) The resistance to surface abrasion of coarse aggregate used in surface courses in accordance with BS EN 13043 clause 4.2.3 and BSI PD 6682-2 clause 3.3.3, shall conform to category AAV<sub>10</sub> unless otherwise specified in the appropriate Clause or in contract specific Appendix 7/1.

(05/18) **Chemical Requirements**

(05/18) **Dicalcium Silicate Disintegration**

**21** (07/21) Air-cooled blast furnace slag aggregates shall be free from iron dicalcium silicate disintegration as defined in BS EN 13043:2002, clause 4.3.4.1.

(05/18) **Iron Disintegration**

**22** (07/21) Air-cooled blast furnace slag aggregates shall be free from iron disintegration as defined in BS EN 13043:2002, clause 4.3.4.2.

(05/18) **Volume Stability**

**23** (07/21) The volume stability category of steel slag aggregates as defined in BS EN 13043, clause 4.3.4.3 shall not exceed V<sub>10</sub>.

(05/18) **Bitumen**

**24** (07/21) Paving grade bitumen shall comply with BS EN 12591.

**25** (07/21) Polymer modified bitumen shall comply with BS EN 14023.

(05/18) **Asphalt Durability – Base and Binder Course**

**26** (07/21) The water sensitivity of base and binder course mixtures designed in accordance with Clause 929 and to be used on trunk roads including motorways shall be determined by testing in accordance with Method A of BS EN 12697-12.

**27** (07/21) The minimum Indirect Tensile Strength Ratio (ITSR) shall be  $ITSR_{min} 70$ .

**28** (07/21) Mixtures that include 2% hydrated lime filler are deemed to result in mixtures which satisfy water sensitivity requirements and testing is not required. Hydrated lime filler shall be  $Ca(OH)_2$  in the form of hydrated lime, type CL 90-S.

**902** (05/18) **Reclaimed Asphalt**

**1** (05/18) The requirements of this clause apply to all bituminous mixtures containing reclaimed asphalt.

**2** (05/18) Reclaimed asphalt may be used in the production of bituminous surface course, binder course, regulating course and base. Unless otherwise specified in contract specific Appendix 7/1, the use of reclaimed asphalt shall be in accordance with:

- (i) Clause 942 for surface course mixtures specified in Clause 942;
- (ii) BSI PD 6691, B.2.4.4 for Asphalt Concrete mixtures (macadams);
- (iii) BSI PD 6691, C.2.3.4 for Hot Rolled Asphalt mixtures;
- (iv) BSI PD 6691, D.2.2.3 for Stone Mastic Asphalt mixtures.

Other recycled materials shall only be used in bituminous mixtures with the approval of the Overseeing Organisation. The mixed material shall comply with the requirements of all the relevant Clauses in this Series.

(05/18) **Reclaimed Feedstock**

**3** (05/18) All reclaimed material shall be pre-treated before use such that it is homogeneously mixed and the maximum particle size does not exceed 32 mm.

(05/18) **Properties of Binder**

**4** (05/18) The fresh bitumen added to the mixture shall not be more than two grades softer than the nominal grade for the mixture given in Table 12 of BSI PD 6691. Checks on the penetration of the binder recovered from the reclaimed asphalt, together with a calculation of the properties of the combined binder, shall be carried out in accordance with the relevant parts of BS EN 13108. When more than 10% of reclaimed asphalt is incorporated in a mixture, tests on binder recovered from the mixture shall be carried out following the example in BSI PD 6691 13.3.6.2. The results shall be within the limits set out in BSI PD 6691 13.3.6.2.

(05/18) **Mixed materials containing more than 25% reclaimed asphalt**

**5** (05/18) When more than 25% of reclaimed asphalt is incorporated in a designed base or binder course mixture, cores taken to assess compliance with Clause 929.12 or Clause 930.14 shall also be tested for stiffness in accordance with BS EN 12697-26 (ITSM method 20°C). The frequency of testing shall be agreed with the Overseeing Organisation prior to the commencement of works and shall comply with the requirements of contract specific Appendices 1/5 and 1/6.

6 (05/18) The stiffness of the mixture shall comply with the appropriate category from Table 9/1.

**TABLE 9/1: (05/18) Stiffness Categories for Designed Base and Binder Course Mixtures Incorporating Greater than 25% Reclaimed Asphalt**

Nominal binder grade of mixture	Stiffness category ( $S_{min}$ )
10/20	5500
15/25	5500
30/45	2800
40/60	1800

### 903 (05/18) Placing and Compaction of Bituminous Mixtures

#### (05/18) General

- 1 (05/18) This Clause gives general requirements for the placing and compaction of bituminous mixtures, which are complementary and additional to the requirements of BS 594987. These requirements and the requirements of BS 594987 apply to all bituminous mixtures, unless otherwise specified in the other Clauses in this Series or in contract specific Appendix 7/1.
- 2 (07/21) Bituminous pavements shall be laid by organisations registered to and operating in compliance with BS EN ISO 9001 'National Highways Sector Scheme 16 for the Laying of Asphalt Mixes' or equivalent listed in Appendix A and constructed using the materials specified in contract specific Appendix 7/1.
- 3 (07/21) There shall be full interlayer bonding between bituminous layers. This may be achieved by keeping the surface of the bituminous layers clean and uncontaminated, and by excluding moisture.
- 4 (07/21) Unless agreed with the Overseeing Organisation, the only traffic permitted to run on the surface of bituminous material to be overlaid shall be that engaged in laying and compacting the next course or, where a binder course is to be blinded or surface dressed, that is engaged on such surface treatment.
- 5 (07/21) If full interlayer bonding cannot be achieved due to surfaces becoming contaminated, the surfaces shall be made good by cleaning and, if this proves impracticable, by rectification in compliance with Clause 702.
- 6 (07/21) Prior to placing bituminous material on any new or existing bound substrate, a bond coat or shall be applied in accordance with Clauses 920 or 942, as appropriate.
- 7 (07/21) Before work commences, the Contractor shall submit a method statement to the Overseeing Organisation that includes:
  - (i) laying and compaction procedures for each layer – including paving speed and paved width; size, type and number of rollers; number of roller passes; and laying and compaction temperatures;
  - (ii) the joint formation procedures for each layer – including the location of longitudinal and transverse joints; and the method(s) of treating upstanding edges.

#### (05/18) Transporting

8 (07/21) Bituminous mixtures shall be transported in accordance with the requirements of BS 594987 and shall remain covered whilst awaiting tipping.

#### (05/18) Laying

9 (07/21) Bituminous mixtures shall be laid in accordance with the requirements of BS 594987 and sub-Clauses 10 to 19 of this Clause.

10 (07/21) Surfacing specified under Clause 942 shall also be laid in accordance with the additional requirements of that Clause.

11 (07/21) Wherever practicable, bituminous mixtures shall be spread, levelled and tamped by a self-propelled paving machine.

12 (07/21) Where the rate of delivery of material to the paver is intermittent for any reason, and the temperature of the material falls below that recommended by the manufacturer for laying, the cold material shall be removed and a perpendicular joint formed in accordance with Clause 903.35 before laying recommences.

13 (07/21) Hand placing of bituminous mixtures shall be restricted to the following circumstances:

- (i) for laying regulating courses of irregular shape and varying thickness;
- (ii) in confined spaces where it is impracticable for a paver to operate;
- (iii) for footways;
- (iv) at the approaches to expansion joints at bridges, viaducts or other structures; and
- (v) for laying mastic asphalt.

14 (07/21) Hand-raking of surface course material or the addition of such material by hand-spreading to the paved area, for adjustment of level, shall be restricted to the following circumstances:

- (i) at the edges of the layers of material and at gullies, manholes and other ironwork; and
- (ii) at the approaches to expansion joints at bridges, viaducts or other structures.

15 (07/21) The method of laying shall be such that the finished mat is free from dragging, tearing and segregation of the material.

16 (07/21) When laying mixtures from more than one source, the mixtures shall have equivalent laying and compaction characteristics so that surface evenness is not compromised.

17 (07/21) When paving adjacent to an expansion joint of a structure, the joint or joint cavity shall be kept clear of material.

18 (07/21) When laying binder course or surface course, the paver shall be taken out of use whilst laying the remainder of the pavement up to the joint and the corresponding area beyond it.

19 (07/21) When paving directly onto bridge deck waterproofing systems, any special requirements which apply to that system shall be complied with.

#### (05/18) **Compaction**

20 (07/21) The compaction of bituminous mixtures shall be in accordance with BS 594987 and the requirements for specific mixtures in:

- (i) Clause 929 for dense base and binder course asphalt concrete (design mixtures);
- (ii) Clause 930 for EME2 mixtures; and
- (iii) Clause 942 for thin surface course systems.

21 (07/21) Except where otherwise specified, rollers shall comply with the general requirements of BS 594987.

22 (07/21) The minimum mass of deadweight smooth wheeled rollers shall be 8 tonnes.

23 (07/21) Multi-wheeled pneumatic tyred rollers and vibratory rollers shall only be used if they are capable of achieving at least the standard of compaction of an 8-tonnes deadweight roller.

24 (07/21) Where compaction is to be determined in accordance with Clauses 929 and 930, the requirements to prove the performance of rollers do not apply. In such cases, the Contractor is permitted use any plant to achieve the specified level of compaction and shall carry out compaction at temperatures above the minimum specified rolling temperature.

25 (07/21) Vibratory rollers shall not be used in vibrating mode on bridge decks.

(05/18) **Chippings**

**26** (07/21) The application of coated chippings to areas of surface course shall be by a mechanical spreader capable of distributing chippings to an even rate of spread.

**27** (07/21) Addition of chippings by hand operation shall only be permitted in the following circumstances:

- (i) in confined spaces, where it is impracticable for a chipping spreader to operate;
- (ii) as a temporary expedient, when adjustments have to be made to the spreader distribution mechanism;
- (iii) when hand laying of the surface course is permitted; and
- (iv) to correct uneven distribution of chippings.

**28** (07/21) Chippings shall be applied uniformly and rolled into the surface so they are effectively held and provide the initial macrotexture depth specified in Clause 921.

(05/18) **Joints**

**29** (07/21) For new, widened and realigned pavement construction, all longitudinal joints in all layers shall be situated outside wheel track zones.

**30** (07/21) For the purposes of this Clause, for a 3.65m wide lane, the wheel track zones shall be taken to be between 0.5m and 1.1m and between 2.55m and 3.15m from the centre of the nearside lane markings for each traffic lane (or, in the absence of lane markings, lane edges).

**31** (07/21) Where the lane width is other than 3.65m then each wheel track zone shall be taken to be 0.6m wide with the inside edges of the wheel track offset from the centre of the lane by 0.72m.

**32** (07/21) Where an existing road pavement is resurfaced, joints in the surface course shall coincide with either the lane edge, the lane marking, or the middle of a traffic lane, whichever is appropriate.

**33** (07/21) Joints shall not coincide with the wheel path.

**34** (07/21) Stepping of all joints shall be offset by 300mm from parallel joints in the layer beneath.

**35** (07/21) Where indicated on the drawings, or in contract specific Appendix 7/1, that the requirements of 300mm steps and prohibition of joints in wheel track zones cannot be met, for example due to new lane configuration, the joints shall be offset as close as practicable to 300mm but not less than 150mm and only if the layer above is less than 150mm thick.

**36** (07/21) Unless otherwise specified in contract specific Appendix 7/1, the faces of all cold upstanding edges, including previously laid asphalt, against which bituminous mixtures are to be laid to form joints shall be treated with one of the following:

- (i) hot bituminous binder with a penetration value of not less than 40/60;
- (ii) hot elastomeric polymer-modified bituminous binder complying with BS EN 14023 with a penetration Class 4; and
- (iii) cold applied thixotropic bituminous compound of similar bitumen or polymer-modified bitumen grade; or
- (iv) polymer-modified adhesive bitumen strip with a minimum thickness of 2mm.

**37** (07/21) This operation shall be done so that the binder adheres to both the cold and the warm upstanding edges when the asphalt is placed.

**38** (07/21) Unless otherwise specified in contract specific Appendix 7/1, joints in binder courses and bases shall be compacted such that the air voids content measured from core pairs whose centres are not more than 100mm from the final joint is not greater than 2% above the maximum permitted limit for core pairs in the body of the mat.

**39** (07/21) The air voids content shall be calculated in accordance with BS EN 12697-8 using the relevant bulk and maximum densities defined in Appendix B of BS EN 13108-20 for the relevant mixture type.

**40** (07/21) Within 24 hours of the joint being formed, a sealant shall be applied to the top surface of all base and binder course joints such that there is not less than 0.50 kg/m<sup>2</sup> of residual bitumen 75mm either side of the joint, unless otherwise specified in contract specific Appendix 7/1.

**41** (07/21) The sealant, which may contain mineral filler to BS EN 13043, shall be one of the following:

- (i) hot elastomeric polymer-modified bituminous binder complying with BS EN 14023 with a penetration Class 4;
- (ii) bitumen emulsion with a cohesion by pendulum of Class 4 or above in accordance with BS EN 13808; or
- (iii) slurry surfacing complying with Clause 918.

(05/18) **Regulating Course**

**42** (07/21) Regulating course material shall be produced and laid in accordance with the requirements of Clause 907.

(05/18) **Use of Surfaces by Traffic**

**43** (07/21) Where a new bituminous layer other than the surface course is to be opened to highway traffic as a temporary running surface it shall either:

- (i) be surface dressed in accordance with Clause 919 using chippings of category not less than PSV<sub>50</sub>, unless otherwise specified in contract specific Appendix 7/1; or
- (ii) contain a coarse aggregate of category of not less than PSV<sub>50</sub>, unless otherwise specified in contract specific Appendix 7/1.

**44** (07/21) Construction plant and traffic shall not be permitted to damage the subgrade or the pavement courses already constructed.

**45** (07/21) Temporary running surfaces used by construction traffic shall be kept free of deleterious materials.

**904** (05/18) **Hot Rolled Asphalt Base**

**1** (05/18) Hot Rolled Asphalt base recipe mixes shall conform to BS EN 13108-4, the detailed requirements of the example in BSI PD 6691 Annex C and requirements specified in contract specific Appendix 7/1. The mixture designation shall be one of the following:

- (i) HRA 60/32 base 40/60.
- (ii) HRA 60/32 base 30/45.
- (iii) HRA 60/20 base 40/60.
- (iv) HRA 60/20 base 30/45.

**905** (05/18) **Hot Rolled Asphalt Binder Course (Recipe Mixtures)**

**1** (05/18) Hot Rolled Asphalt binder course recipe mixes shall conform to BS EN 13108-4, the example in BSI PD 6691 Annex C and requirements specified in contract specific Appendix 7/1. The mixture designation shall be one of the following:

- (i) HRA 60/32 bin 40/60.
- (ii) HRA 60/32 bin 30/45.
- (iii) HRA 60/20 bin 40/60.
- (iv) HRA 60/20 bin 30/45.

### 906 (05/18) Dense Base and Binder Course Asphalt Concrete (Recipe Mixtures)

1 (05/18) Dense base and binder course asphalt concrete (formerly macadam) recipe mixtures shall be asphalt concrete conforming to BS EN 13108-1, the detailed requirements from BSI PD 6691 Annex B and requirements specified in contract specific Appendix 7/1. The mixture designation shall be one of the following:

- (i) AC 32 dense base 40/60 rec.
- (ii) AC 32 dense base 100/150 rec.
- (iii) AC 32 dense base 160/220 rec.
- (iv) AC 32 dense bin 40/60 rec.
- (v) AC 32 dense bin 100/150 rec.
- (vi) AC 32 dense bin 160/220 rec.
- (vii) AC 20 dense bin 40/60 rec.
- (viii) AC 20 dense bin 100/150 rec.
- (ix) AC 20 dense bin 160/220 rec.

### 907 (05/18) Regulating Course

1 (05/18) Regulating courses, which may consist of one or more layers of a bituminous material, shall have their finished surfaces laid to achieve the appropriate tolerances for horizontal alignments, surface levels and surface regularity for pavement layers, in accordance with Clause 702.

2 (05/18) Unless otherwise specified in contract specific Appendix 7/1, stone mastic asphalt complying with Clause 937, or base or binder course asphalt concrete complying with Clause 929 or hot rolled asphalt complying with Clause 943, shall be used for regulating courses immediately below surface courses. Bituminous mixtures for regulating courses shall meet the requirements for the appropriate material, as specified above.

3 (05/18) Where the total depth of a regulating course exceeds 150 mm then the course shall be laid so that each regulating layer has a compacted thickness of between 75 mm and 150 mm.

### 908 (07/21) Warm Mix Asphalt (WMA)

#### (07/21) WMA General

1 (07/21) WMAs shall be installed in accordance with the producer's instructions.

#### (07/21) WMA Permitted Mixtures

2 (07/21) Mixtures produced as Warm Mix Asphalts shall fulfil the requirements given in:

- (i) Clause 906 for Dense Base and Binder Course Asphalt Concrete with Paving Grade Bitumen (Recipe Mixtures);
- (ii) Clause 912 for Close Graded Asphalt Concrete Surface Course;
- (iii) Clause 929 for Dense Base and Binder Course Asphalt Concrete (Design Mixtures);
- (iv) Clause 930 for EME2 Base and Binder Course Asphalt Concrete;
- (v) Clause 937 for Stone Mastic Asphalt (SMA) Binder Course and Regulating Course;
- (vi) Clause 942 for Thin Surface Course Systems; and
- (vii) Clause 901 and Clause 903 and contract specific Appendix 7/1.

3 (07/21) Warm mixtures conforming to Clause 942 shall have Product Acceptance Scheme certification for their installation in compliance with sub-Clause 104.16 and Clause 942 to demonstrate their performance.

4 (07/21) For the purposes of traceability, the mixture designation shall include a reference to the use of warm mix technologies e.g AC20 bin HDM 40/60 "W".

(07/21) **WMA Production Temperatures**

5 (07/21) The maximum production temperatures, when measured in accordance with BS EN 12697-13, shall be in accordance with Table 9/1A and the material's Declaration of Performance and not compromise the efficacy of the binder, additives or process.

**Table 9/1A (07/21) Maximum production temperatures for WMAs incorporating paving grade binders, hard paving grade binders or Polymer Modified Binders**

Binder grade	Maximum Temperature (°C) (at any stage)
Paving grade conforming to BS EN 12591	150
Hard paving grade conforming to BS EN 13924-1	160
Polymer Modified Binder conforming to BS EN 14023	Documented and declared by the producer

(07/21) **Water Sensitivity**

6 (07/21) Unless otherwise stated in contract specific Appendix 7/1, the water sensitivity expressed as an Indirect Tensile Strength Ratio or Compression strength ratio shall be in accordance with Table 9/1B and contract specific Appendix 7/1 and be declared on the Declaration of Performance.

7 (07/21) Designated WMA mixtures in Table 9/1B which include 2% hydrated lime filler aggregate are deemed to result in mixtures which satisfy water sensitivity requirements and testing is not required. Hydrated lime filler shall be Ca(OH)<sub>2</sub> in the form of hydrated lime, type CL 90-S.

**Table 9/1B (07/21) Minimum Water Sensitivity Values for Warm Mix Asphalts**

Material Clause and Description	SHW Clause	ITSR <sub>min</sub>	BS EN 12697 12 Test Method
Dense Base and Binder Course Asphalt Concrete (Design Mixtures)	929	80	A
Stone Mastic Asphalt (SMA) Binder Course and Regulating Course	937		
Thin Surface Course Systems	942		
EME2 Base and Binder Course Asphalt Concrete	930	See sub-clause 930.21	B

(07/21) **WMA Installation**

8 (07/21) Mixtures produced as WMA shall comply with the requirements in Clause 903, contract specific Appendix 7/1, Table 9/1C and the producer's recommendations and not compromise the efficacy of the WMA binder, additives or process.

**Table 9/1C (07/21) Minimum Rolling Temperatures for WMAs Incorporating Paving Grade Binders, Hard Paving Grade Binders or Polymer Modified Binders**

Binder grade	Minimum Temperature (°C) (immediately prior to rolling)
Paving grade conforming to BS EN 12591	90
Hard paving grade conforming to BS EN 13924-1	110
Polymer Modified Binder conforming to BS EN 14023	Documented and declared by the producer

**(07/21) WMA Carbon Footprint (Reduction) Measurement**

**9** (07/21) The Contractor shall report CO<sub>2</sub> emissions for asphalt using the calculation tool detailed at: <https://www.gov.uk/government/publications/carbon-tool>.

**10** (07/21) A cradle-to-gate carbon footprint analysis shall be submitted by the Contractor to the Overseeing Organisation and for Highways England contracts by email to: [aspect@highwaysengland.co.uk](mailto:aspect@highwaysengland.co.uk) for each WMA mixture in accordance with sub-Clause 9.

**11** (07/21) The carbon footprint analysis shall be conducted in accordance with TRL PPR 575 – Protocol for the calculation of whole life cycle greenhouse gas emissions generated by asphalt, covering Steps 1 to 5 of the asphalt life cycle, from ‘raw material acquisition’ to ‘road component production’.

**12** (07/21) The carbon footprint shall be stated in kgCO<sub>2</sub>e per tonne of the warm mixture and broken down into totals for Steps 1-3, Step 4 and Step 5.

**909 (05/18) 6 mm Dense Asphalt Concrete Surface Course**

**1** (05/18) 6 mm dense asphalt concrete (formerly macadam) surface course shall be asphalt concrete conforming to BS EN13108-1, the example in BSI PD 6691 Annex B and requirements specified in contract specific Appendix 7/1. The mixture designation shall be one of the following:

- (i) AC 6 dense surf 100/150.
- (ii) AC 6 dense surf 70/100.

**(05/18) Coarse Aggregate**

**2** (05/18) To ensure adequate resistance to polishing and abrasion, the coarse aggregate shall have a minimum declared PSV as specified in contract specific Appendix 7/1, in accordance with BS EN 13043:2002, clause 4.2.3. and BSI PD 6682-2, and shall have a maximum declared AAV, as specified in contract specific Appendix 7/1, in accordance with BS EN 13043:2002, clause 4.2.4 and BSI PD 6682-2.

**910 (05/18) Hot Rolled Asphalt Surface Course (Recipe Mixtures)**

**1** (05/18) Hot Rolled Asphalt surface course recipe mixtures shall conform to BS EN 13108-4, the example of BSI PD 6691 Annex C, and the requirements specified in contract specific Appendix 7/1. Unless otherwise specified in contract specific Appendix 7/1, the mixture designation shall be one of the following:

- (i) HRA 0/2 F surf 40/60.
- (ii) HRA 15/10 F surf 40/60.
- (iii) HRA 30/10 F surf 40/60.
- (iv) HRA 30/14 F surf 40/60.
- (v) HRA 35/14 F surf 40/60.

When the mixture designation is not specified in contract specific Appendix 7/1, the mixture selected by the Contractor shall be notified to the Overseeing Organisation prior to its use in the works.

(05/18) **Coarse Aggregate**

**2** (05/18) The resistance to polishing of the coarse aggregate for chipped mixtures shall be category  $PSV_{44}$  as defined in BS EN 13043:2002, clause 4.2.3. For unchipped mixtures, the coarse aggregate shall have a minimum declared PSV and a maximum AAV as specified in contract specific Appendix 7/1.

(05/18) **Coated Chippings**

**3** (05/18) When required, coated chippings shall be either 14/20 mm or 8/14 mm, as specified in contract specific Appendix 7/1 and comply with Clause 915.

**#911 (05/18) Hot Rolled Asphalt Surface Course (Design Mixtures)**

**1** (05/18) Hot Rolled Asphalt surface course design mixes shall conform to BS EN 13108-4, the example of BSI PD 6691 Annex C and requirements specified in contract specific Appendix 7/1. The mixture designation shall be one of the following:

- (i) HRA 0/2 F surf xx/yy des.
- (ii) HRA 30/14 F surf xx/yy des.
- (iii) HRA 35/14 F surf xx/yy des.
- (iv) HRA 55/10 F surf xx/yy des.
- (v) HRA 55/14 F surf xx/yy des.
- (vi) HRA 0/2 C surf xx/yy des.
- (vii) HRA 30/14 C surf xx/yy des.
- (viii) HRA 35/14 C surf xx/yy des.
- (ix) HRA 55/10 C surf xx/yy des.
- (x) HRA 55/14 C surf xx/yy des.

Unless otherwise specified in contract specific Appendix 7/1, the grade of bitumen required (xx/yy) shall be 40/60.

(05/18) **Coarse Aggregate**

**2** (05/18) The resistance to polishing of the coarse aggregate for chipped mixtures shall be category  $PSV_{44}$  as defined in BS EN 13043:2002, clause 4.2.3. For unchipped mixtures, the coarse aggregate shall have a minimum declared PSV and a maximum AAV as specified in contract specific Appendix 7/1.

(05/18) **Coated Chippings**

**3** (05/18) When required, coated chippings shall be either 14/20 mm or 8/14 mm in accordance with BSI PD 6682-2, as specified in contract specific Appendix 7/1. Coated chippings shall also comply with Clause 915.

**912 (05/18) Close Graded Asphalt Concrete Surface Course**

**1** (05/18) Close graded asphalt concrete (formerly macadam) surface course recipe mixes shall be asphalt concrete conforming to BS EN 13108-1, the example of BSI PD 6691 Annex B and requirements specified in contract specific Appendix 7/1. The mixture designation shall be one of the following:

- (i) AC 10 close surf 100/150.

- (ii) AC 10 close surf 70/100.
- (iii) AC 14 close surf 100/150.
- (iv) AC 14 close surf 70/100.

(05/18) **Coarse Aggregate**

2 (05/18) To ensure adequate resistance to polishing and abrasion, the coarse aggregate shall have a minimum declared PSV and a maximum AAV, as specified in contract specific Appendix 7/1.

**913 (05/18) Not Used**

**914 (05/18) Fine Graded Asphalt Concrete Surface Course**

1 (05/18) Fine graded asphalt concrete (formerly macadam) surface course recipe mixes shall be asphalt concrete conforming to BS EN 13108-1, the example of BSI PD 6691 Annex B and requirements specified in contract specific Appendix 7/1. The mixture designation shall be one of the following:

- (i) AC 4 fine surf 160/220.
- (ii) AC 4 fine surf 250/330.

(05/18) **Coarse Aggregate**

2 (05/18) To ensure adequate resistance to polishing and abrasion, the coarse aggregate shall have a minimum declared PSV and a maximum AAV, as specified in contract specific Appendix 7/1.

**915 (05/18) Coated Chippings for Application to Hot Rolled Asphalt Surfacing**

1 (05/18) Coated chippings for rolling into the surface of hot rolled asphalt shall conform to BS EN 13108-4, the example in BSI PD 6691 Annex C clause C.2.8 and requirements specified in contract specific Appendix 7/1.

2 (05/18) To ensure adequate resistance to polishing and abrasion, the coarse aggregate shall have a minimum declared PSV and a maximum AAV, as specified in contract specific Appendix 7/1.

3 (05/18) The shape of the chippings shall comply with category  $FI_{20}$  as defined in BS EN 13043:2002 clause 4.1.6.

**916 & 917 (05/18) Not used**

**918 (05/18) Slurry Surfacing Incorporating Microsurfacing**

1 (05/18) The Contractor shall be responsible for the design of the Slurry Surfacing, choice of materials, techniques and processes based on site and traffic data specified in contract specific Appendix 7/7 and the schedule of constraints on site availability in contract specific Appendix 1/13.

2 (05/18) The Contractor shall:

- (i) Provide a Design Proposal to achieve the performance requirements in terms of texture and maximum levels of defects as set out in this Clause and in contract specific Appendix 7/7 ensuring that the Slurry Surfacing has an initial stability such that it is capable of withstanding the normal traffic for the site when first opened.
- (ii) State the Estimated Design Life of the Slurry Surfacing in the Design Proposal.

- (iii) Provide a Quality Plan.
- (iv) Carry out the Slurry Surfacing in accordance with the manufacturers installation instructions and the Design Proposal to the thickness and tolerances specified in contract specific Appendix 7/7.

**3** (05/18) The Contractor shall guarantee the design, materials and workmanship against defects and against failure to meet the end performance requirements for a period of two years, or as otherwise specified in contract specific Appendix 7/7, from the date of completion of the work. The Contractor shall rectify any defects identified during the guarantee period.

(05/18) **The System**

**4** (05/18) The proposed Slurry Surfacing shall comply with BS EN 12273 and it shall be CE marked. The Contractor shall provide the declaration of performance and installation information as required in this Clause and contract specific Appendix 7/7.

The declaration of performance shall demonstrate that the system meets the requirements of the specification and provides performance categories for all of the items identified in this Clause and in contract specific Appendix 7/7.

(05/18) **Aggregates**

**5** (05/18) The aggregate shall be crushed rock, slag, gravel or calcined bauxite, complying with this specification. The coarse aggregate shall have a minimum declared PSV and a maximum AAV as specified in contract specific Appendix 7/7. In the Design Proposal the Contractor shall provide the declaration of performance for the aggregate which shall demonstrate that the aggregate shall meet the requirements of the specification including the properties detailed in contract specific Appendix 7/7. The grading and binder content shall not differ from the proposed target values by more than the tolerances detailed in the Design Proposal.

(05/18) **Binder**

**6** (05/18) The Contractor shall provide, with his Design Proposal, the declaration of performance for the binder which shall demonstrate that the binder shall meet the requirements of the specification including the properties detailed in contract specific Appendix 7/7.

Contract compliance testing shall be carried out by the Contractor as detailed in contract specific Appendix 1/5. The recovery of the binder shall be carried out in accordance with Clause 955. The test to determine Vialit Pendulum Cohesion shall be carried out in accordance with BS EN 13588. The Contractor shall provide rheological product identification data for modified binders in accordance with BS EN 14770.

(05/18) **Coloured Materials**

**7** (05/18) Where required in contract specific Appendix 7/7 a coloured slurry surfacing shall be provided. All coloured slurry surfacings shall be approved by the Overseeing Organisation. They shall conform in all respects with the requirements of this Clause.

(05/18) **Equipment**

**8** (05/18) The mixing machine shall be capable of uniform application and the provision of a continuous surface without ridges or segregation.

(05/18) **Health and Safety**

**9** (05/18) Health and Safety information and safe handling guidance shall be provided by the Contractor to the Overseeing Organisation.

(05/18) **Layer Thickness**

**10** (05/18) When required, the minimum and/or maximum thickness of the Slurry Surfacing shall be as specified in contract specific Appendix 7/7.

(05/18) **Preparation**

**11** (05/18) Any necessary remedial works to the road surface and structure shall be completed either prior to the commencement of works, or as part of the contract and agreed as acceptable by the Overseeing Organisation and the Contractor before Slurry Surfacing commences.

**12** (05/18) Street furniture, and where specified in contract specific Appendix 7/7, road markings and kerbs, shall be masked using self-adhesive masking material or other material firmly secured against the passage of the spreader box or the tools used for hand laying. Any packed mud or other deposits on the road surface shall be removed, all organic growth shall be removed by suitable means, and the road surface shall be swept free of all loose material.

**13** (05/18) A bond coat complying with Clause 920 shall be applied prior to the Slurry Surfacing with or without grit or chippings in order to seal the existing substrate and to enhance the bond to the existing road surface unless the Contractor can demonstrate that sufficient bond will be developed without its use. This treatment shall be in accordance with the Contractor's method statement contained within his Design Proposal.

(05/18) **Traffic Safety and Management**

**14** (05/18) Traffic Safety and Management shall be strictly in accordance with the requirements of Series 100 and the site specific requirements specified in contract specific Appendix 1/17 and the constraints described in contract specific Appendix 1/13.

(05/18) **Mixing**

**15** (05/18) The Slurry Surfacing shall be mixed in a continuous flow mixing machine and discharged directly into the spreader box. Where the material is to be hand laid the Slurry Surfacing may be mixed in a batch mixer or supplied to site pre-mixed in suitable containers. The Quality Plan shall detail the precautions to be taken to achieve a homogeneous mixture.

(05/18) **Application**

**16** (05/18) Application restrictions to be observed in the event of adverse weather shall be as specified in this Clause, the Contractor's Method Statement and any additional requirements specified in contract specific Appendix 7/7.

**17** (05/18) Transverse joints shall be formed with spreading starting and finishing on a protective strip not less than 100 mm wide at each end of the lane length or area being treated or such other method as defined in the Contractor's Method Statement to produce an equivalent standard. Transverse joints shall be formed such that there shall be no ridges or bare strips.

**18** (05/18) Unless otherwise agreed with the Overseeing Organisation, longitudinal joints, where the material is laid on a road, shall coincide with lane markings. Longitudinal joints shall be formed such that there shall be no ridges or bare strips.

**19** (05/18) Handwork around street furniture and other ironwork shall meet the same performance requirements and form a homogeneous surface with the rest of the treated carriageway.

**20** (05/18) Footways and other confined areas may be spread by hand using squeegees and brooms. Kerb edges and other areas not being treated shall be suitably masked with self-adhesive masking material. Footways shall be finished by dragging a dampened broom transversely over the footway under its own weight or other method producing a similar macrotexture or as stated in contract specific Appendix 7/7.

**21** (05/18) All voids, cracks and surface irregularities shall be completely filled. Spreading shall not be undertaken on carriageways when the temperature falls below 4°C or when standing water is present on the surface. In warm dry weather, the surface immediately ahead of the spreading, shall be slightly damped by mist water spray applied mechanically, or for hand laying by a hand operated pressure sprayer, unless otherwise agreed by the Overseeing Organisation.

**22** (05/18) The finished Slurry Surfacing shall have a uniform surface macrotexture throughout the work, without variations of macrotexture within the lane width, or from area to area.

**23** (05/18) The finished surface shall be free from blow holes and surface irregularities due to scraping, scabbing, score marks, dragging, droppings, excess overlapping or badly aligned longitudinal or transverse joints, damage by rain or frost, or other defects which remain 24 hours after laying. Slurry Surfacing which does not comply with this Clause or is non-uniform in surface macrotexture or colour, 24 hours after laying shall be rectified by removal and replacement, or superimposed if this is impractical, with fresh material in compliance with this Clause. Areas so treated shall be not less than 5 m long and not less than one lane wide (or the full width if less than a lane wide). All areas being worked on shall be kept free of traffic until the material has set sufficiently to carry the traffic.

**24** (05/18) The Contractor shall record the amount of Slurry Surfacing used and the area covered for each run or section completed.

**25** (05/18) The Contractor shall facilitate duplicate or joint testing by the Overseeing Organisation if required.

(05/18) **Aftercare**

**26** (05/18) Masking shall be removed after the Slurry Surfacing has been applied, without damage to the edge of the surfacing, and before opening the road or footway to traffic. The ironwork shall be reset, if necessary, within 48 hours of application of the Slurry Surfacing.

**27** (05/18) The Contractor shall remove surplus aggregate from the treated areas using a method stated in the Quality Plan. The Contractor shall monitor the Slurry Surfacing closely for a minimum period of 2 hours and if necessary the lane shall be swept again. The monitoring shall continue until the Slurry Surfacing has reached sufficient stability to carry unrestricted traffic. If there are signs of distress the Contractor shall reinstate traffic safety and management procedures or other such remedial action where necessary in order to prevent further damage.

**28** (05/18) Further operations to remove subsequently loosened aggregate shall be carried out over the next 48 hours. The areas treated and adjacent side roads, footways and paved areas shall be kept substantially free of loose aggregate for a period of 30 days after completion of the work.

(05/18) **As Built Manual**

**29** (05/18) Not more than 30 days after completion of the work the Contractor shall provide a record of the progress of the work in the form of an As Built Manual incorporating all relevant information, including all contract compliance test results, volumes of Slurry Surfacing used and areas covered with calculated thickness, record of traffic control carried out, weather information, unforeseen problems, a list of complaints, if any, from the general public or road users and any other information that the Overseeing Organisation may reasonably require to be included.

(05/18) **Performance Standards for Slurry Surfacing During the Guarantee Period**

(05/18) **Surface Macrotexture**

**30** (05/18) The Contractor is responsible for maintaining the surface macrotexture requirements set out in contract specific Appendix 7/7 throughout the guarantee period.

The definitive test is the volumetric patch technique measured in accordance with BS EN 13036-1 except that 10 individual measurements shall be made on the nearside (inside) wheel-track of the most heavily trafficked lane or for low traffic category sites the track carrying the most stress. The average macrotexture depth of each lane kilometre, or the complete carriageway lane where this is less than 1,000 metres, shall be as specified in contract specific Appendix 7/7. The average of each set of 10 individual measurements shall be not less than 80% of the minimum permitted.

(05/18) **Surface Profile**

**31** (05/18) The surface profile of the slurry surfacing, when measured in accordance with Series 700, shall meet the requirements specified in contract specific Appendix 7/7 for both transverse and longitudinal profile.

(05/18) **Defects**

**32** (05/18) When the extent of area and linear defects is monitored using the visual method of assessment in accordance with BS EN 12274-8 the Slurry Surfacing shall have less than the permitted maximum level of defects as described in contract specific Appendix 7/7.

**33** (05/18) Coloured materials shall retain their colour throughout the guarantee period to the level stated in the contract specific Appendix 7/7.

**34** (05/18) Any section failing to meet the required standard as specified in contract specific Appendix 7/7 shall be subject to remedial action by the Contractor.

**919** (05/18) **Surface Dressing: Recipe Specification**

**1** (05/18) The Contractor shall:

- (i) Carry out the Surface Dressing in accordance with the design described in contract specific Appendix 7/21 subject to the schedule of constraints on site availability set out in contract specific Appendix 1/13. The supply and application of Surface Dressing to road surfaces shall be undertaken by organisations registered to the National Highways Sector Scheme 13 for The Supply and Application of Surface Treatments to Road Surfaces listed in Appendix A.
- (ii) Be responsible for the choice of materials, techniques and processes subject to the requirements described in contract specific Appendix 7/21. The tolerances permitted for this work shall be as specified in contract specific Appendix 7/21.
- (iii) Provide a Quality Plan, which may be subject to audit by the Overseeing Organisation with respect to the method of executing the work.
- (iv) Guarantee the materials and workmanship against defects and against failure to meet the specification for a period of one year, or as otherwise described in contract specific Appendix 7/21, from the date of completion of the work.

(05/18) **Materials and Equipment – Binder**

**2** (05/18) The binder shall be of the type and grade specified in the contract specific Appendix 7/21, complying with BS EN13808 and be CE marked.

**3** (05/18) The Contractor shall provide a Binder Data Sheet giving details of the properties specified in contract specific Appendix 7/21 for each binder proposed. Contract compliance testing shall be carried out as detailed in contract specific Appendix 1/5. The test to determine the Vialit Pendulum Cohesion shall be carried out in accordance with BS EN 13588. The Contractor shall provide rheological product identification data for modified binders in accordance with BS EN 14770. Health and Safety information and a safe handling guide from the manufacturer shall be provided together with details of any weather restrictions placed upon the use of the binder.

**4** (05/18) The binder sprayer shall be capable of uniform application at the designed rate of spread over a variable or fixed width sufficient to allow a full lane width to be produced in a single pass. Before spraying begins the Contractor shall provide the Overseeing Organisation with a test certificate showing test results for rate of spread and accuracy of spread of binder carried out in accordance with the test methods in BS EN 12272-1 issued by an appropriate organisation accredited in accordance with sub-Clause 105.4 for those tests demonstrating that the binder sprayer has been tested, using the binder to be used in the Contract, not more than six weeks before the commencement of the work, and that it complies with the requirements set out in contract specific Appendix 7/21.

(05/18) **Materials and Equipment – Chippings**

**5** (05/18) The chippings shall be crushed rock, slag, gravel or calcined bauxite complying with BS EN 13043:2002, and shall be CE marked and be of the size specified in contract specific Appendix 7/21. In his proposals, the Contractor shall state the source and characteristics of chippings to be used and the coating, if any. The coarse

aggregate shall have a minimum declared PSV and a maximum AAV as specified in contract specific Appendix 7/21. The shape of the chipping shall comply with category  $FI_{20}$  as defined in BS EN 13043:2002, clause 4.1.6. Contract compliance testing shall be carried out as required and at the frequency specified in contract specific Appendix 1/5.

**6** (05/18) The chipping spreader shall have controlled metering and be capable of variable or fixed width application to match the binder sprayer. Before a spreader is used, the Contractor shall provide to the Overseeing Organisation a test certificate showing test results for rate of spread and accuracy of spread of chippings in accordance with the test methods in BS EN 12272-1 issued by an appropriate organisation, accredited in accordance with sub-Clause 105.4 for those tests, or tests carried out under his own quality management scheme demonstrating that the chipping spreader has been tested, using chippings similar to those to be used in the Contract, not more than six weeks before the commencement of the work, and that it complies with the requirements set out in contract specific Appendix 7/21.

(05/18) **Preparation**

**7** (05/18) Any necessary remedial works to the road surface and structure shall be completed either prior to commencement of the works, or as part of the contract and agreed as acceptable by the Overseeing Organisation and the Contractor before Surface Dressing commences.

**8** (05/18) Before binder is applied, street furniture shall be masked using self-adhesive masking material. Oil, sand or similar materials shall not be used. Any packed mud or other deposits on the road surface shall be removed, and the road surface shall be swept free of all loose material.

**9** (05/18) Traffic Safety and Management shall be in accordance with the requirements of Series 100 and the site specific requirements specified in contract specific Appendix 1/17 and the constraints described in contract specific Appendix 1/13.

(05/18) **Application**

**10** (05/18) Binder shall be applied to the road surface at the rates specified in the design. The Contractor shall mark out areas where an adjusted binder rate is needed, because of localised conditions and note such changes in the As Built Manual. Application restrictions to be observed in the event of adverse weather shall be as specified below together with any additional limitations set out in contract specific Appendix 7/21.

- (i) When there is precipitation.
- (ii) When there is free water on the surface.
- (iii) When the air temperature is at or below the values given in Table 9/2.
- (iv) For emulsion binders when the relative humidity exceeds 80%.
- (v) When the road surface temperature exceeds 35°C for roads carrying over 200 cv/lane/day or 40°C below that traffic level.

**TABLE 9/2:** (05/18) **Air Temperature for Spraying**

Binder	Uncoated chippings	Coated chippings
	Minimum °C	Minimum °C
Bitumen emulsion	10	–
All modified binders and fluxed binders	Manufacturer's recommendation	Manufacturer's recommendation

**11** (05/18) Transverse joints shall be formed with spraying starting and finishing on a protective strip not less than 1 metre wide at each end of the lane length being treated. Transverse joints shall be of binder overlap only and not wider than 100 mm. There shall be no ridges or bare strips.

Longitudinal joints shall coincide with lane markings. Longitudinal joints shall be of binder overlap only while ensuring that the proposed rate of spread is achieved across the joint. For quartering (using a part of the spraybar) the overlap may be extended to a maximum of 300 mm. There shall be no ridges or bare strips.

**12** (05/18) The Contractor shall carry out the tests for rates of spread and accuracy of application of binder and chippings in accordance with the test methods in BS EN 12272-1 at the frequency specified in contract specific Appendix 1/5 and report the results verbally to the Overseeing Organisation within 24 hours of carrying out the test and confirm in writing within 7 days. The Contractor shall facilitate duplicate testing by the Overseeing Organisation if required.

**13** (05/18) Rolling shall be performed by rubber coated vibratory steel rollers and/or pneumatic tyred rollers as specified in Clause 903. The rollers shall have fully operating sprinkler systems, spraying water or other release agent onto the drum or tyres, so that if the chippings start to move under the roller exposing binder the sprinklers are available immediately.

(05/18) **Aftercare**

**14** (05/18) Masking shall be removed after the Surface Dressing has been applied and before opening the road to unrestricted traffic. The Contractor shall remove surplus chippings from the road by suction sweeping before it is opened to unrestricted traffic.

**15** (05/18) The Contractor shall monitor the Surface Dressing closely for a minimum period of 2 hours, or as specified in contract specific Appendix 7/21, after the road is opened to traffic. The Contractor shall reinstate traffic safety and management procedures or institute other remedial action where necessary, such as dusting, if there are signs of distress, such as turning of the chippings, in order to prevent further damage to the Surface Dressing.

**16** (05/18) Further operations to remove subsequently loosened chippings shall be carried out over the next 48 hours. The road, and adjacent side roads, footways and paved areas, shall be kept substantially free of loose chippings for a period of 30 days after completion of the work.

**17** (05/18) Any defects arising from deficiencies in the materials, workmanship and aftercare manifest during or at the end of the maintenance period shall be rectified by the Contractor at his own expense.

(05/18) **As Built Manual**

**18** (05/18) Not more than 30 days after completion of the work the Contractor shall provide a record of the progress of the work in the form of an As Built Manual incorporating all relevant information, including all test results; variations to the design and those necessitated by localised site conditions; weather information; unforeseen problems; a list of complaints, if any, from the general public or road users; and any such other information that the Overseeing Organisation may reasonably require to be included.

## **920** (05/18) **Bond Coats, Tack Coats and Other Bituminous Sprays**

**1** (05/18) Bond coats and tack coats used in conjunction with bituminous mixtures, other than those covered by Clause 942, shall be in accordance with this Clause and the requirements specified in contract specific Appendix 7/1 and 7/4.

(05/18) **Bond Coats**

**2** (05/18) Bond coats for bituminous mixtures shall be cationic polymer modified bitumen emulsions complying with BS EN 13808 or polymer modified bitumen complying with BS EN 14023 with a minimum peak cohesion value of 1.0 J/cm<sup>2</sup> when tested in accordance with BS EN 13588. They shall be CE marked and the Contractor shall submit the declaration of performance to the Overseeing Organisation prior to their application. The declaration of performance shall demonstrate that the bond coat meets the requirements of the specification.

(05/18) **Tack Coats**

**3** (05/18) Tack coats for bituminous mixtures shall be unmodified bitumen emulsion complying with BS EN 13808. They shall be CE marked and the Contractor shall submit the declaration of performance to the Overseeing Organisation prior to their application. The declaration of performance shall demonstrate that the tack coat meets the requirements of the specification.

(05/18) **Bituminous Sprays**

4 (05/18) Bituminous sprays used to facilitate sealing and curing shall consist of either bitumen emulsion complying with BS EN 13808 or paving grade bitumen complying with BS EN 12591. They shall be CE marked and the Contractor shall submit the declaration of performance to the Overseeing Organisation prior to their application. The declaration of performance shall demonstrate that the spray meets the requirements of the specification.

(05/18) **Product Information**

5 (05/18) For bond coats, tack coats and bituminous sprays the Contractor shall provide the information specified in contract specific Appendix 7/4 and supply a copy to the Overseeing Organisation prior to the application of the product.

(05/18) **Preparation**

6 (05/18) The Contractor shall comply with any limitations on area availability and timing or other constraints for the work as specified in contract specific Appendix 1/13. Before spraying is commenced, the surface shall be free of all loose material and standing water and shall comply with any requirements specified in contract specific Appendix 7/4. When specified in contract specific Appendix 7/4, street furniture, ironwork and drop-kerbs shall be masked using self-adhesive masking material before application starts and removed on completion of the works.

(05/18) **Application**

7 (05/18) Application shall be by metered mechanical spraying equipment, spray tanker or spraying device integral with the paving machine. The spraying equipment used shall not cause permanent deformation in the surface. For small or inaccessible areas, application may be by hand held sprayer with the agreement of the Overseeing Organisation.

8 (05/18) The target rates of spread of bond coats or tack coats below bituminous mixtures shall be in accordance with BS 594987, clause 5.5. For other applications, unmodified bitumen emulsions shall be sprayed at the rate of spread specified in BS 434-2 or as stated in contract specific Appendix 7/4.

(05/18) **Accuracy of Application**

9 (05/18) Spray application shall be uniform. Before spraying begins, the Contractor shall provide the Overseeing Organisation with a test certificate showing the results for rate of spread and accuracy of spread. These tests shall be carried out in accordance with BS EN 12272-1 by an appropriate organisation, accredited in accordance with sub-Clause 105.4 for those tests. The certificate shall demonstrate that the spraying device has been tested, using the product to be used in the contract, not more than six weeks before commencement of the work. The tolerance on the specified rate of spread shall not exceed  $\pm 20\%$  and the coefficient of variation of the transverse distribution shall not exceed 15%. During the works the Contractor shall repeat the tests for rate of spread and accuracy of application at the frequency specified in contract specific Appendix 1/5. The results shall be reported verbally to the Overseeing Organisation within 24 hours of carrying out a test and in writing within 7 days. Where application is by hand held sprayer, the rate of spread shall be measured by calculating the volume applied per square metre and evenness shall be visually assessed.

(05/18) **Joints**

10 (05/18) There shall be no bare strips or areas having less than the minimum permitted rate of spread. Transverse joints shall have an overlap not wider than 300 mm. Longitudinal joints shall have an overlap to ensure that the minimum permitted rate of spread is achieved across the joint. For quartering (using part of the spraybar) the longitudinal joint overlap width may be extended to a maximum of 300 mm. Paver integral sprayers shall provide a wet edge to ensure spray overlap under adjacent overlays such that the minimum permitted rate of spread is achieved across the longitudinal joint. Where the longitudinal spray overlap causes the effective rate of spread to be increased by more than 50% of the specified rate, then the width of overlap shall not be greater than 100 mm and shall be outside the location of the wheel tracks for the lane.

(05/18) **Overlaying Concrete Surfaces**

**11** (05/18) The Contractor shall submit evidence of the suitability of the bond or tack coats he intends to use when overlaying concrete surfaces to the Overseeing Organisation prior to the commencement of the work.

(05/18) **Blinding Material for Bituminous Sprays**

**12** (05/18) When specified in contract specific Appendix 7/4, blinding material shall consist of hard clean crushed fine aggregate or slag fine aggregate or sand containing not more than 15% by mass retained on a 6.3 mm sieve. It shall be distributed over the sprayed area and left. Blinding used on cementitious materials shall be light in colour to minimise solar gain. All loose material on a sprayed surface including non-adhered blinding material shall be removed prior to the application of an overlay.

(05/18) **Chipping to Prevent Binder Pickup**

**13** (05/18) When chippings are used to prevent tack or bond coat pickup on vehicle tyres, they shall consist of hard, clean aggregate 2/4 mm or 2/6 mm Gc 85/35. The rate of application of aggregate shall be the minimum necessary and shall be distributed by metered mechanical means. Bond coat shall be visible after aggregate application to ensure bond is still achieved between the pavement layers.

**921** (05/18) **Surface Macrotexture of Bituminous Surface Courses**

**1** (05/18) Surface macrotexture of bituminous surface courses other than those covered by Clause 942, shall be in accordance with this Clause where unless otherwise specified in contract specific Appendix 7/1. Initial surface macrotexture for bituminous surface courses shall be measured using the volumetric patch method described in BS EN 13036-1.

**2** (05/18) Texture depth shall be measured by 10 individual measurements taken at approximately 5 m spacing along a diagonal line across the lane width. Unless otherwise specified in contract specific Appendix 7/1, at least one set of 10 measurements shall be made for each 250 m section of carriageway lane. The average texture depth for each set of 10 individual measurements and the average texture depth of each 1,000 m section (or complete carriageway lane where this is less than 1,000 m) shall not be less than the appropriate values shown in Table 9/3, unless otherwise specified in contract specific Appendix 7/1.

**TABLE 9/3: (05/18) Requirements for Initial Texture Depth for Materials Other Than Those Covered by Clause 942**

Road Type	Surfacing Type	Average per 1,000 m section, mm		Average for a set of 10 Measurements, mm (minimum)
		Minimum	Maximum	
<b>High speed roads</b> Posted speed limit $\geq$ 50 miles/hr (80 km/hr)	Cold applied ultra thin surface course systems to Clause 923	1.5	2.0	1.2
	Chipped hot rolled asphalt, and all other surfacings:	1.5	2.0	1.2
<b>Lower speed roads</b> Posted speed limit $\leq$ 40 miles/hr (65 km/hr)	Cold applied ultra thin surface course systems to Clause 923	1.5	2.0	1.2
	Chipped hot rolled asphalt, and all other surfacings:	1.2	1.7	1.0
<b>Roundabouts on high speed roads</b> Posted speed limit $\geq$ 50 miles/hr (80 km/hr)	Chipped hot rolled asphalt, and all other surfacings:	1.2	1.7	1.0
<b>Roundabouts on lower speed roads</b> Posted speed limit $\leq$ 40 miles/hr (65 km/hr)	Chipped hot rolled asphalt, and all other surfacings	1.0	1.5	0.9

**922 (05/18) Surface Dressing: Design, Application and End Product Performance**

**1** (05/18) The Contractor shall be responsible for the design of the Surface Dressing, choice of materials, techniques and processes based on site and traffic data specified in contract specific Appendix 7/3 and the schedule of constraints on site availability in contract specific Appendix 1/13.

**2** (05/18) The Contractor shall:

- (i) Provide a Design Proposal to achieve the performance requirements in terms of macrotexture and maximum levels of defects as set out in this Clause and in contract specific Appendix 7/3 ensuring that the Surface Dressing has an initial stability such that it is capable of withstanding the normal traffic for the site when first opened.
- (ii) State the Estimated Design Life of the Surface Dressing in the Design Proposal.
- (iii) Provide a Quality Plan.
- (iv) Carry out the Surface Dressing in accordance with BS EN 12271 and the Design Proposal to the tolerances specified in contract specific Appendix 7/3.

**3** (05/18) The Contractor shall guarantee the design, materials and workmanship against defects and against failure to meet the end product performance requirements for a period of two years, or as otherwise specified in contract specific Appendix 7/3, from the date of completion of the work. The Contractor shall rectify any defects identified during the guarantee period.

**(05/18) The System**

**4** (05/18) The proposed Surface Dressing shall comply with BS EN 12271 and it shall be CE marked. The Contractor shall provide the declaration of performance and installation information as required in this Clause and contract specific Appendix 7/3.

The declaration of performance shall demonstrate that the system meets the requirements of the specification and provides performance categories for all of the items identified in this Clause and contract specific Appendix 7/3.

(05/18) **Materials and Equipment – Binder**

5 (05/18) The binder shall be bitumen emulsion complying with BS EN 13808 and be CE marked and comply with requirements stated in contract specific Appendix 7/3.

6 (05/18) The Contractor shall provide, with his Design Proposal, the declaration of performance for the binder which shall demonstrate that the binder shall meet the requirements of the specification including the properties detailed in contract specific Appendix 7/3.

Contract compliance testing shall be carried out as detailed in contract specific Appendix 1/5. The recovery of the binder shall be carried out in accordance with Clause 955. The test to determine Vialit Pendulum Cohesion shall be carried out in accordance with BS EN 13588. The Contractor shall provide rheological product identification data for modified binders in accordance with BS EN 14770. The data provided shall be not more than 6 months old and obtained on samples of binder representative of binder manufactured and supplied using the same source and processes as the proposed binder. Health and Safety information and a safe handling guide from the manufacturer shall be provided together with details of any weather restrictions placed upon use of the binder.

7 (05/18) The binder application shall be uniform and for motorways, trunk roads and heavily trafficked and highly stressed roads, shall be of sufficient width to allow a full lane to be dressed in a single pass. Before spraying begins, the Contractor shall provide the Overseeing Organisation with a test certificate showing test results for rate of spread and accuracy of spread of binder carried out in accordance with the test methods in BS EN 12272-1 and issued by, an appropriate organisation, accredited in accordance with sub-Clause 105.4 for those tests, demonstrating that the binder sprayer has been tested, using the binder to be used in the Contract, not more than six weeks before the commencement of the work, and that it complies with the requirements set out in contract specific Appendix 7/3.

(05/18) **Materials and Equipment – Chippings**

8 (05/18) The chippings shall be crushed rock, slag, gravel or calcined bauxite complying with the general requirements of BS EN 13043:2002. The aggregate shall have a minimum declared PSV and a maximum AAV as specified in contract specific Appendix 7/3.

9 (05/18) Chipping spreaders shall have controlled metering and be capable of variable or fixed width application to match the binder sprayer. Before a spreader is used, the Contractor shall provide the Overseeing Organisation with a test certificate showing test results for rate of spread and accuracy of spread of chippings carried out in accordance with the test methods in BS EN 12272-1, and issued by an appropriate organisation, accredited in accordance with sub-Clause 105.4 for those tests, demonstrating that the chipping spreader has been tested, using chippings similar to those to be used in the Contract, not more than six weeks before the commencement of the work, and that it complies with the requirements set out in contract specific Appendix 7/3.

(05/18) **Preparation**

10 (05/18) Any necessary remedial works to the road surface and structure shall be completed prior to or as part of the contract and agreed as acceptable by the Overseeing Organisation and the Contractor before Surface Dressing commences.

11 (05/18) Before binder is applied, street furniture shall be masked using self-adhesive masking material. Oil, sand or similar materials shall not be used. Any packed mud or other deposits on the road surface shall be removed, and the road surface shall be swept free of all loose material.

(05/18) **Traffic Safety and Management**

12 (05/18) Traffic Safety and Management shall be in accordance with the requirements of Series 100 and the site specific requirements specified in contract Appendix 1/17 and the constraints described in contract specific Appendix 1/13.

(05/18) **Application**

**13** (05/18) Restrictions to be observed in the event of adverse weather shall be as specified in contract specific Appendix 7/3. Transverse joints shall be formed with spraying starting and finishing on a protective strip not less than 1 metre wide at each end of the lane length being treated. Transverse joints shall be of binder overlap only and not wider than 100 mm. There shall be no ridges or bare strips. Longitudinal joints shall coincide with lane markings. Longitudinal joints shall be of binder overlap only, while ensuring that the proposed rate of spread is achieved across the joint, for quartering (using a part of the spraybar) the overlap may be extended to a maximum of 300 mm. There shall be no ridges or bare strips.

**14** (05/18) The Contractor shall carry out the tests for rates of spread and accuracy of application of binder and chippings in accordance with the test methods in BS EN 12272-1 at the frequency specified in contract specific Appendix 1/5 and report the results verbally to the Overseeing Organisation within twenty-four hours of carrying out the test and confirm in writing within seven days. The Contractor shall facilitate duplicate testing by the Overseeing Organisation if required.

(05/18) **Aftercare**

**15** (05/18) Masking shall be removed after the Surface Dressing has been applied and before opening the road to unrestricted traffic. The time period before unrestricted traffic may use the Surface Dressing shall not exceed that specified in contract specific Appendix 7/3. The Contractor shall remove surplus chippings from the road by suction sweeping before it is opened to unrestricted traffic.

**16** (05/18) The Contractor shall monitor the Surface Dressing closely for a minimum period of 2 hours, or as specified in contract specific Appendix 7/3, after the road is opened to traffic. The Contractor shall reinstate traffic safety and management procedures or institute other such remedial action where necessary, such as dusting, if there are signs of distress, such as turning of the chippings, in order to prevent further damage to the Surface Dressing.

**17** (05/18) Further operations to remove subsequently loosened chippings shall be carried out over the next 48 hours. The road, and adjacent side roads, footways and paved areas, shall be kept substantially free of loose chippings for a period of 30 days after completion of the work.

(05/18) **As Built Manual**

**18** (05/18) Not more than 30 days after completion of the work the Contractor shall provide a record of the progress of the work in the form of an As Built Manual incorporating all relevant information, including: all contract compliance test results; variations to the Design Proposal and those necessitated by localised site conditions; a record of traffic control carried out; weather information; unforeseen problems; a list of complaints, if any, from the general public or road users; and any other information that the Overseeing Organisation may reasonably require to be included.

(05/18) **Performance Standards During the Guarantee Period**

(05/18) **Surface Macrotexture**

**19** (05/18) The Contractor is responsible for maintaining the surface macrotexture requirements set out in contract specific Appendix 7/3 throughout the guarantee period.

The definitive test is the volumetric patch technique measured in accordance with BS EN 13036-1 except that 10 individual measurements shall be made on the nearside (inside) wheel-track of the most heavily trafficked lane. The average macrotexture depth of each lane kilometre, or the complete carriageway lane where this is less than 1,000 metres, shall be as specified in contract specific Appendix 7/3. The average of each set of 10 individual measurements shall be not less than 80% of the minimum permitted.

The Overseeing Organisation will use the TRAFFIC-speed Condition Survey (TRACS) or other suitable equipment to determine the Sensor Measured Texture Depth (SMTD) for trunk roads including motorways and other highly trafficked or highly stressed roads. Measurements of SMTD shall be made in the nearside and offside wheel-tracks of all lanes. For other roads where road closure is less critical the volumetric patch technique or other measuring device such as the Mini Texture Meter may be used.

The SMTD or results from other devices shall be calibrated for the particular Surface Dressing product design and condition against volumetric patch values to provide the Volumetric Patch Equivalent value. The macrotexture depths will be measured after 11 months and before 13 months and additionally for two year guarantee period contracts after 22 months and before 24 months unless otherwise specified in contract specific Appendix 7/3. When required, the Contractor shall design the Surface Dressing to limit the maximum macrotexture after four weeks trafficking to that specified in contract specific Appendix 7/3 and the macrotexture depths will be measured, for this purpose, between three weeks and five weeks after completion of the Works.

(05/18) **Defects**

**20** (05/18) The extent of chipping loss or other defects will be monitored using a visual method of assessment. The performance standard is that any section of the works shall be deemed as having failed if the areas of defects do not comply with the classes specified in contract specific Appendix 7/3. If there is a failed section, the Contractor shall agree remedial measures with the Overseeing Organisation and undertake the remedial measures.

In the event that the Contractor and Overseeing Organisation are unable to reach agreement on whether a section has failed by qualitative visual assessment described in BS EN 12272-2, the level of defects shall be determined in accordance with the quantitative test methods in BS EN 12272-2. Any section failing to meet the required standard as specified in contract specific Appendix 7/3 shall be subject to remedial action by the Contractor after agreement of the Overseeing Organisation.

**923** (05/18) **Cold Applied Ultra Thin Surfacing**

(05/18) **General**

**1** (05/18) The Cold Applied Ultra Thin Surfacing shall meet the product performance requirements under the combinations of traffic level and site classification specified in contract specific Appendix 7/1 and it shall meet the following criteria.

- (i) Where the product falls under the scope of a harmonised European standard under the Construction Products Regulation the Cold Applied Ultra Thin Surfacing shall have a declaration of performance and be CE marked in accordance with the relevant British adopted European standard.
- (ii) Where the product does not fall under the scope of a harmonised European standard under the Construction Products Regulation it shall either:
  - (a) have a declaration of performance and be CE marked in accordance with a European Technical Assessment; or
  - (b) be certified under a product acceptance scheme as detailed in sub-Clauses 104.15 and 104.16 such as HAPAS certification.

The Contractor shall supply the certification or declaration of performance to the Overseeing Organisation, it shall demonstrate that the Cold Applied Ultra Thin Surfacing shall meet the requirements of the specification.

The installation of the surfacing shall be certified under a product acceptance scheme as detailed in sub-Clauses 104.15 and 104.16 such as HAPAS certification.

**2** (05/18) Cold Applied Ultra Thin Surfacing systems that are supplied in accordance with sub-Clause 1 paragraph (ii) (b) shall be produced and installed by organisations that are registered to the National Highways Sector Scheme 13 for The Supply and Application of Surface Treatments to Road Surfaces, as listed in Appendix A.

(05/18) **Documentation, Test Certificates and Material Samples**

**3** (05/18) The Contractor shall supply a Quality Plan and Installation Method Statement to the Overseeing Organisation.

**4** (05/18) Test certificates stating the properties of the aggregate to be used shall be supplied to the Overseeing Organisation unless the values are declared in the Declaration of Performance under the CE mark.

5 (05/18) The details of the component materials and their relative proportions and/or spread rates for use in the permanent works shall be notified to the Overseeing Organisation. The component materials listed shall include, as appropriate, coarse aggregates, fine aggregates, filler, additives (including fibres), binder, modifier and bond coat, and shall be subdivided into layers if applied.

6 (05/18) When required in contract specific Appendix 1/6, samples of aggregate, bond coat or binder, modified or unmodified bitumen from either the spray bar or storage tank or mixed bituminous materials from the pavement surface or other suitable sampling point shall be supplied to the Overseeing Organisation.

(05/18) **Aggregates**

7 (05/18) Coarse aggregate shall be crushed rock or steel slag complying with Clause 901 when tested in accordance with the procedures of BS EN 13043:2002. The coarse aggregate shall additionally have the following properties.

- (i) Polished Stone Value (PSV) – as specified in contract specific Appendix 7/1 – BS EN 13043:2002;
- (ii) Aggregate Abrasion Value (AAV) – as specified in contract specific Appendix 7/1 – BS EN 13043:2002;
- (iii) Los Angeles Coefficient (LA) – not greater than  $LA_{30}$  – BS EN 13043:2002;
- (iv) Flakiness Index (FI) – not more than  $FI_{20}$  – BS EN 13043:2002.

(05/18) **Performance Levels**

8 (05/18) Cold Applied Ultra Thin Surfacing is permitted on Site Categories B, C, D, E, F and G as defined in Table 9/4.

**TABLE 9/4: (05/18) Site Stress Level Classification**

Site Category	Site Definition	Stress Level
A	Motorway (main line)	1
B	Dual carriageway (all purpose) non-event sections	1
C	Single carriageway non-event sections	1
D	Dual carriageway (all purpose) minor junctions	1
E	Single carriageway minor junctions	1
F	Approaches to and across major junctions (all limbs)	2
G	Gradient >5%, longer than 50 m (Dual downhill; single uphill and downhill)	2
H1	Bend (not subject to 40 mph or lower speed limit) radius 100 – 250 m	2
H2	Bend (not subject to 40 mph or lower speed limit) radius <100 m	3
L	Roundabout	3
J	Approach to roundabout	4
K	Approach to traffic signals, pedestrian crossing, railway level crossing and similar	4

9 (05/18) The road/tyre noise level of the cold applied ultra thin surface shall be as specified in contract specific Appendix 7/1, as defined in Table 9/5.

**TABLE 9/5:** (05/18) **Road/Tyre Noise Levels**

Level	Road Surface Influence RSI
0	+1.2 dB(A)
NR	No requirement

(05/18) **Layer Thickness**

**10** (05/18) The minimum and/or maximum compacted thickness of the Cold Applied Ultra Thin Surfacing system shall be as specified in contract specific Appendix 7/1. The installed layer thickness must not be less than the permitted minimum thickness stated in the HAPAS certificate or equivalent certification for a particular system.

(05/18) **Surface Preparation**

**11** (05/18) When required in contract specific Appendix 7/1, a site inspection shall be undertaken prior to the main works jointly by representatives of the Overseeing Organisation and the Contractor to agree suitable preparation works (e.g. patching).

**12** (05/18) Surface preparation shall be in accordance with BS 594987, clause 5.1 and 5.3, and the Installation Method Statement provided in accordance with sub-Clause 4.

(05/18) **Transportation**

**13** (05/18) Transportation of the Cold Applied Ultra Thin Surfacing and/or its components shall be in accordance with the Installation Method Statement provided in accordance with sub-Clause 4.

(05/18) **Sweeping and early life monitoring of Cold Applied Ultra Thin Surfacing**

**14** (05/18) Sweeping of newly laid Cold Applied Ultra Thin Surfacing shall be in accordance with the HAPAS or equivalent certification and the Installation Method Statement.

**15** (05/18) Notwithstanding the above, suction sweeping shall be undertaken immediately before the newly laid Cold Applied Ultra Thin Surfacing is opened to traffic.

**16** (05/18) The installation shall be monitored closely for a minimum period of 2 hours after the road is opened to traffic. Traffic safety and management procedures shall be reinstated or other such remedial actions instigated, if there are signs of distress in the surfacing, such as turning of the chippings, in order to prevent further damage to the installation.

**17** (05/18) Where detailed in contract specific Appendix 1/17 a mandatory speed limit shall be implemented during installation and for a period of 5 days after installation.

**18** (05/18) Further operations to remove subsequently loosened chippings shall be carried out over the next 48 hours. The road, and adjacent side roads, footways and paved areas shall be kept substantially free of loose chippings for a period of 30 days after completion of the surfacing work.

(05/18) **Surface Macrotexture – Untrafficked**

**19** (05/18) The macrotexture depth of the cold applied ultra thin surfacing after compaction has been completed and before opening to traffic shall be in accordance with Clause 921.

(05/18) **Surface Macrotexture – Performance Guarantee**

**20** (05/18) For a period of two years from the date of opening to traffic the average macrotexture, measured using the volumetric patch technique described in BS EN 13036-1, will be maintained above an average per 1000m of 1.0 mm, unless otherwise specified in contract specific Appendix 7/1.

**21** (05/18) Where measurement is necessary to demonstrate compliance during the guarantee period, the macrotexture shall be measured in accordance with BS EN 13036-1 in the most heavily trafficked lane at 10 m intervals. The average value of a set of 10 individual measurements taken along the centre of the most heavily worn wheel-track shall not be less than the appropriate value stated in contract specific Appendix 7/1.

(05/18) **Surfacing Integrity – Performance Guarantee**

**22** (05/18) Unless otherwise stated in contract specific Appendix 7/1 a guarantee shall be provided for the integrity of the surfacing and the workmanship for a period of five years from the date of opening to traffic.

**23** (05/18) The five-year guarantee shall include for defects such as fretting, ravelling, stripping and loss of chippings. Replacement of the surfacing or other remedial measures agreed with the Overseeing Organisation shall be executed if the surfacing is in a “Suspect”, “Poor” or “Bad” condition as defined in Appendix A of TRL Report TRL674 – “Durability of thin surfacing systems, Part 4, Final report after nine years monitoring, TRL report 674”.

**924** (05/18) **High Friction Surfaces**

**1** (05/18) High friction surfacing systems shall have current HAPAS certificate or equivalent product acceptance scheme certification as described in sub-Clauses 104.15 and 104.16.

**2** (05/18) High friction surfacing shall be installed in accordance with the requirements of the HAPAS or equivalent product acceptance scheme certification.

**3** (05/18) The high friction surfacing system HAPAS or equivalent product acceptance scheme certification Type Classification required for each location shall be as specified in contract specific Appendix 7/1.

(05/18) **Aggregate**

**4** (05/18) Aggregate used in high friction surfacing systems shall have the minimum declared PSV category specified in contract specific Appendix 7/1 in accordance with BS EN 13043:2002, clause 4.2.3. The resistance to abrasion of coarse aggregate shall have the maximum AAV specified in contract specific Appendix 7/1 in accordance with BS EN 13043:2002, clause 4.2.4. The Contractor shall provide, before work commences, the declaration of performance for the aggregate to the Overseeing Organisation. The declaration of performance shall demonstrate that the aggregate shall meet the requirements of the specification.

(05/18) **Installation and Quality Control Procedures**

**5** (05/18) The installation and quality control procedures shall be in accordance with the HAPAS or equivalent product acceptance scheme certification for each system and the current method statement. The results of all quality control checks carried out on site by the Contractor and quality management information compiled in accordance with the requirements of the Certificate, including results from surveillance visits, shall be made available to the Overseeing Organisation on request.

(05/18) **System Coverage**

**6** (05/18) For each location where high friction surfacing is applied, the total quantities of each system component used, the measured area of the surface treated and the calculated coverage rate in kg/m<sup>2</sup> shall be reported to the Overseeing Organisation within three days of completion at that location. For systems in which aggregate is broadcast over a film of binder applied to the surface, the calculated coverage rate shall be that of the binder film and shall not include the mass of the aggregate.

(05/18) **Guarantee**

**7** (05/18) The Contractor shall guarantee the high friction surfacing materials and workmanship for a period of two years from the date of opening the surfacing to traffic. This guarantee shall cover failure to meet the minimum requirements set out in Table 4 of the HAPAS document ‘Guideline Document for the Assessment and Certification of High Friction Surfaces for Highways’.

## 925 (05/18) Testing of Bituminous Mixtures

- 1 (05/18) The contract compliance sampling and testing of bituminous mixtures shall comply with BS EN 12697, except where otherwise specified in this Series.
- 2 (05/18) Additional testing shall be carried out as specified in contract specific Appendices 7/1, 1/5 and 1/6.

## 926 (05/18) In Situ Recycling: The Repave Process

- 1 (05/18) Where milling is required, it shall be carried out in accordance with Clause 709, and as described in contract specific Appendix 7/5.

### (05/18) Heating and Scarifying

- 2 (05/18) Surfaces to be treated shall be heated by plant with heating surfaces insulated and fully enclosed. The heated-width of surfacing shall exceed the scarified width by at least 75 mm on each side, except against the edge of the carriageway or kerb face. When new surfacing material is spilt onto the road surface it shall be removed before the existing surface is heated and scarified. Areas of unscarified material shall not exceed 50 mm x 50 mm.
- 3 (05/18) The depth of scarification shall be such that the bottom of the scarified layer is parallel to and below the finished road surface level by the thickness of surface course material specified in contract specific Appendix 7/5. A tolerance of  $\pm 6$  mm is permissible.
- 4 (05/18) Where ironwork and other obstructions occur, these shall be suitably protected or removed and the void covered. Surface dressings and large areas of road markings shall be removed by milling, planing, scarifying or similar.
- 5 (05/18) The heated surface shall be evenly scarified to comply with the requirements of sub-Clause 3 of this Clause. When ironwork is left in place or raised, the adjacent areas shall be scarified by other means, with the material either left in place or removed, prior to passage of the machine. If ironwork needs to be re-levelled, on completion of work, the new surface course material shall be used to make good the road surface for a maximum width of 200 mm around the ironwork.
- 6 (05/18) During the reheating process the surface temperature of the road shall not exceed 200°C for more than 5 minutes.

### (05/18) New Surfacing

- 7 (05/18) New surface course shall conform to Clauses 910, 911, 923, 942 or 943, as described in contract specific Appendix 7/5.
- 8 (05/18) The new surfacing material shall be laid on, and compacted with the re-profiled surfacing, which shall be at a temperature within the range of 70°C to 150°C.

**927 & 928 (05/18) Not Used**

**929 (05/18) Dense Base and Binder Course Asphalt Concrete (Design Mixtures)**

1 (05/18) Designed dense base and binder course asphalt concrete (formerly macadams), including HDM and HMB, shall be asphalt concrete conforming to BS EN 13108-1, the example of BSI PD 6691 Annex B for the selected mixture, and requirements specified in contract specific Appendix 7/1. The mixture designation shall be one of the following:

- (i) AC 32 HDM base 40/60 des.
- (ii) AC 32 dense base 40/60 des.
- (iii) AC 32 HMB base 30/45 des.
- (iv) AC 20 HDM bin 40/60 des.
- (v) AC 32 HDM bin 40/60 des.
- (vi) AC 20 dense bin 40/60 des.
- (vii) AC 32 dense bin 40/60 des.
- (viii) AC 20 HMB bin 30/45 des.
- (ix) AC 32 HMB bin 30/45 des.

2 (05/18) The volumetric properties of mixtures shall follow the example in BSI PD 6691, clause B.3.2 for designed base mixtures and BSI PD 6691, clause B.3.3 for designed binder course mixtures.

3 (05/18) When specified in contract specific Appendix 7/1, the volumetric properties of the mixture shall be monitored by determining the void content of cores compacted to refusal. Core pairs and samples of loose mix shall be taken every 500 lane metres and tested in accordance with BS 594987, clauses C.2.1, C.2.2, C.3, C.4.1 and C.4.2. If the mean air void content at refusal of any three consecutive pairs of cores falls below 0.5%, the mixture target composition shall be reviewed and the type test revalidated in accordance with BS 594987, Annex C.

(05/18) **Deformation Resistance**

4 (05/18) The resistance to permanent deformation of the mixture shall be in accordance with the appropriate class selected from Table D.2 of PD 6691, as specified in contract specific Appendix 7/1.

5 (05/18) When specified in contract specific Appendix 7/1, the resistance to permanent deformation of material laid in the permanent works shall be monitored by testing in accordance with clauses D 3.1, 3.2 and 3.3 of BS 594987 Annex D. Six cores shall be taken from the first kilometre length of material from each mixing plant and thereafter one further core from each subsequent lane kilometre. Results shall be assessed on successive rolling means of sets of six consecutive results and shall be deemed to conform if the mean is no greater than the specified value and individual values not more than 50% greater than the specified value.

(05/18) **Stiffness**

6 (05/18) Stiffness of the mixture shall be assessed in accordance with BS 594987, Annex E.

Mixtures with 40/60 grade binder shall conform to category  $S_{\min 1800}$  as defined in BS EN 13108-1, clause 5.4.2.

Mixtures with 30/45 grade binder shall conform to category  $S_{\min 2800}$  as defined in BS EN 13108-1, clause 5.4.2.

(05/18) **Compaction Control for the Permanent Works**

7 (05/18) Compaction shall be controlled and monitored in accordance with the general requirements of BS 594987 9.5.1 and the specific requirements of this Clause.

- 8** (05/18) Compaction shall be continuously assessed using an indirect density gauge in accordance with BS 594987 9.4.2 with readings taken at 20 m intervals in alternate wheel-tracks. Gauge readings shall also be taken at each core location specified in sub-Clauses 12 and 14. Each gauge shall be individually calibrated on each mixture from each mixing plant and the calibrations shall be continually checked and updated based on correlations between gauge readings and core densities at the same locations.
- 9** (05/18) For each location, the in situ void content shall be determined in accordance with BS EN 12697-8 using the bulk density from the gauge reading and a maximum density taken from the mixture type testing data and updated with values from testing in accordance with sub-Clause 12.
- 10** (05/18) The average in situ void content calculated from any six consecutive indirect gauge readings shall not exceed 7%.
- 11** (05/18) In the event of a failure to meet the requirements in sub-Clause 10, cores shall be taken at each location and void contents determined as described in sub-Clause 12 and the evaluation of the extent of any non-conformity shall be based on these. If it is necessary to remove and replace any material to restore conformity this shall be in lengths not less than 15 m unless otherwise agreed by the Overseeing Organisation.
- 12** (05/18) For the material from each mixing plant, a pair of cores shall be taken from every 1,000 linear metres laid and the void content shall be determined in accordance with BS 594987, clause 9.5.1.3.
- 13** (05/18) The average in situ air voids for each core pair shall not exceed 7%.
- 14** (05/18) For the material from each mixing plant a pair of cores shall be taken every 250 linear metres laid, centred 100 mm from the final joint position at any unsupported edge and the air void shall be determined in accordance with BS 594987, clause 9.5.1.3.
- 15** (05/18) The average in situ void content for each of these pairs shall not exceed 9%.
- 16** (05/18) In the event of non-conformity with sub-Clauses 13 or 15 then density readings with indirect gauges and, if necessary, further cores shall be taken to establish the extent. If it is necessary to remove and replace any material to restore conformity, this shall be in lengths not less than 15 m unless otherwise agreed by the Overseeing Organisation.
- 17** (05/18) Each core extracted shall be examined for evidence of excessive voids below the depth to which the indirect density gauge penetrates. If excessive voids are observed, further cores shall be taken to determine its extent.
- 18** (05/18) Two copies of the final indirect density test results obtained and their correlation with in situ air void contents shall be passed to the Overseeing Organisation within 72 hours.

(07/21) **Warm Mix Asphalt (WMA)**

- 19** (07/21) Mixtures to be produced as WMAs shall comply with Clause 908.

**930** (05/18) **EME2 Base and Binder Course Asphalt Concrete**

**1** (05/18) EME2 base and binder course asphalt concrete shall conform to BS EN 13108-1, the example in BSI PD 6691 Annex B for the selected mixture, the requirements of this Clause and those specified in contract specific Appendix 7/1. The mixture designation shall be one of the following:

- (i) AC 10 EME2 bin/base 10/20 des.
- (ii) AC 10 EME2 bin/base 15/25 des.
- (iii) AC 14 EME2 bin/base 10/20 des.
- (iv) AC 14 EME2 bin/base 15/25 des.
- (v) AC 20 EME2 bin/base 10/20 des.
- (vi) AC 20 EME2 bin/base 15/25 des.

2 (05/18) The binder shall be Hard Paving Grade Bitumen in accordance with BS EN 13924 and the requirements specified in Tables 9/6, 9/7 and 9/8.

3 (05/18) EME2 mixtures, otherwise conforming to BS EN 13108-1 and the example in BSI PD 6691 Annex B, but using alternative paving grade bitumens or polymer modified paving grade bitumens, shall not be used without prior approval by the Overseeing Organisation.

**TABLE 9/6: (05/18) Initial Binder Characteristics, as Supplied**

Characteristic	Test Method	Unit	Hard Grade Binders for EME2		FPC
			10/20 pen	15/25 pen	
Penetration at 25°C	EN 1426	0.1mm	10 - 20	15 - 25	D
Softening Point	EN 1427	°C	63 – 73 Target value 71 max <sup>(1)</sup>	60 – 70 Target value 68 max <sup>(1)</sup>	W
Penetration Index, max	EN 13924 Annex A	–	+0.7 Target Value +0.5 max <sup>(1)</sup>	+0.7 Target Value +0.5 max <sup>(1)</sup>	W
Fraass breaking point, max	EN 12593	°C	Target mean <sup>(2)</sup> 0 max Range -15 to +5	Target mean <sup>(2)</sup> 0 max Range -15 to +5	Q
Viscosity at 135°C, min	EN 12595	mm <sup>2</sup> /s	1,100	900	A
Flash point, minimum	EN 12592	°C	245	245	A
Solubility, minimum	EN 12592	%(m/m)	99.0	99.0	A
Notes:					
(1) Target max value based on a rolling mean of the last 6 consecutive results in FPC.					
(2) Target max value based on a rolling mean of the last 3 consecutive results in FPC.					
All tests to be carried out on sub-samples of a single bulk sample of binder.					
Minimum test frequency : D = Daily, W = Weekly, Q = Quarterly, A = Annually.					
(Indicated frequencies apply only if product is in regular supply.)					

**TABLE 9/7: (05/18) Binder Characteristics, After Short-term Ageing to EN 12607-1 (RTFOT)**

Characteristic	Test Method	Unit	Hard Grade Binders for EME2		FPC
			10/20 pen	15/25 pen	Test frequency
Change of mass, max		%	0.5	0.5	A
Retained Pen 25°C	EN 1426	%	65 <sup>(1)</sup>	65 <sup>(1)</sup>	Q
Increase in Softening Point, maximum	EN 1427	°C	8	8	A

Notes:

(1) Target minimum value based on a rolling mean of the last 3 consecutive results in FPC.

All tests to be carried out on sub-samples of a single bulk sample of binder.

Minimum test frequency : A = Annually, Q = Quarterly.

(Indicated frequencies apply only if product is in regular supply.)

**TABLE 9/8: (05/18) Binder Characteristics to be Reported**

Characteristic	Test Method	Unit	Binder for EME2	FPC frequency		
				AS	STA	LTA
Brookfield Viscosity T 200cP	EN 13302	°C	TBR	A		
T 2000cP		°C	TBR		A	
T 5000cP		°C	TBR		A	
G* and Phase Angle	BS EN 14770	Pa, degrees	TBR	A	A	A
VET temperature, G'=G'', at 0.4 Hz		°C	TBR	A	A	A
G* at the VET temperature		Pa	TBR	A	A	A
G' and G'' Mastercurves 80°C to 0°C		Graphical Output	TBR	A	A	A
G'' and Phase Angle at 15°C, 10Hz and 20°C, 1Hz	Graphical Output	Pa, degrees	TBR	A	A	A
T <sub>S=300 MPa</sub> , by BBR		°C	TBR	A	A	A
T <sub>m=0.3</sub> , by BBR	°C	TBR	A	A	A	
Pendulum Cohesion, min	BS EN 13588	J/cm <sup>2</sup>	TBR	A	A	A
Fraass breaking point, min	EN 12593	°C	TBR		A	

Notes:

AS = As Supplied; STA = After EN 12607-1 (RTFOT) \* LTA = After PAV85 \*

\* An ageing profile determined in accordance with clause 955 is an acceptable alternative to STA and PAV85.

All tests to be carried out on sub-samples of a single bulk sample of binder.

Minimum test frequency : A = Annually.

(Indicated frequencies apply only if product is in regular supply.)

**4** (05/18) The properties of mixtures shall follow the example in BSI PD 6691 Annex B, clause 3.4.1 to clause 3.4.7 inclusive.

5 (05/18) A separate assessment shall be made of the conformity of soluble binder content analysis results of EME2 mixtures using the principles of the 'mean of four results' approach used in BS EN 13108-21. Binder content shall be assessed on a continuous basis by taking the mean value of the previous four analysis results. This will give a 'rolling mean binder content'. In addition to the analysis results meeting all of the standard conformity requirements of EN 13108-21, this rolling mean binder content shall comply with the target composition  $\pm 0.3\%$ .

(05/18) **Compaction**

6 (05/18) EME2 shall be delivered to site at a temperature which enables laying with a minimum paver-out temperature of 140°C.

7 (05/18) EME2 mixtures shall be compacted with either:

- (i) steel rollers exceeding 8 tonnes, provided compaction is speedily undertaken. Any vibration shall be switched off when traversing compacted material to avoid micro-cracking the cooling surface;
- (ii) pneumatic tyred rollers (PTR's) weighted at a minimum of 1.0 tonne per wheel, finishing with wide steel non-vibrating rollers and 3-point rollers.

8 (05/18) Compaction shall be substantially completed before the temperature falls below 120°C. Limited rolling without vibration may be carried out below this temperature to improve the finish.

(05/18) **Compaction Control for the Permanent Works**

9 (05/18) Compaction shall be controlled and monitored in accordance with the general requirements of BS 594987 9.5.1 and the specific requirements of this Clause.

10 (05/18) Compaction shall be continuously assessed using an indirect density gauge in accordance with BS 594987 9.4.2 with readings taken at 20 m intervals in alternate wheel-tracks. Gauge readings shall also be taken at each core location specified in sub-Clauses 13 and 14. Each gauge shall be individually calibrated on each mixture from each mixing plant and the calibrations shall be continually checked and updated based on correlations between gauge readings and core densities at the same locations.

11 (05/18) For each location, determine the in situ void content in accordance with BS EN 12697-8 using the bulk density from the gauge reading and a maximum density taken from the mixture type testing data and updated with values from testing in accordance with sub-Clauses 13 and 14.

12 (05/18) The average in situ void content calculated from any six consecutive indirect gauge readings shall not exceed 6%.

13 (05/18) In the event of a failure to meet the requirements in sub-Clause 12, cores shall be taken and void contents determined in accordance with BS 594987, clause 9.5.1.3 and the evaluation of the extent of any non conformity shall be based on these. If it is necessary to remove and replace any material to restore conformity this shall be in lengths not less than 15 m unless otherwise agreed by the Overseeing Organisation.

14 (05/18) For the material from each mixing plant a pair of cores shall be taken from the wheel-tracks every 1,000 metres laid and the void content shall be determined in accordance with BS 594987, clause 9.5.1.3.

15 (05/18) The average in situ air voids for each core pair shall not exceed 6%.

16 (05/18) For the material from each mixing plant a pair of cores shall be taken every 250 metres laid, centred 100mm from the final joint position at any unsupported edge and the air void shall be determined in accordance with BS 594987, clause 9.5.1.3.

17 (05/18) The average in situ void content for each of these pairs shall not exceed 8%

18 (05/18) In the event of non-conformity with sub-Clauses 15 or 17 then density readings with indirect gauges and, if necessary, further cores shall be taken to establish the extent. If it is necessary to remove and replace any material to restore conformity this shall be in lengths not less than 15 m unless otherwise agreed by the Overseeing Organisation.

19 (05/18) Each core extracted shall be examined for evidence of excessive voids below the depth to which the indirect density gauge penetrates. If excessive voids are observed, further cores shall be taken to determine its extent.

20 (05/18) Two copies of the final indirect density test results obtained and their correlation with in situ air void contents shall be passed to the Overseeing Organisation within 72 hours of the material being laid.

(07/21) **Warm Mix Asphalt (WMA)**

21 (07/21) The minimum water sensitivity when tested in accordance with Method B of BS EN 12697-12 shall be  $i/C_{\min 75}$ . This requirement is also deemed to satisfy the requirement for mixtures produced as warm mix asphalts as specified in Clause 908.

22 (07/21) Mixtures to be produced as WMAs shall comply with Clause 908.

**931 to 935 (07/19) Not Used**

**936 (07/19) Geosynthetics and Steel Meshes: Installation and End Product Performance**

1 (07/21) Systems that are intended to suppress reflection cracking in asphalt surfacing by use of an interlayer shall have Product Acceptance Scheme certification in compliance with sub-Clause 104.16 to demonstrate their performance. Systems without Product Acceptance Scheme certification in compliance with sub-Clause 104.16 shall not be used without prior approval by the Overseeing Organisation.

2 (07/19) The Contractor shall be responsible for the installation of geosynthetic or steel mesh systems, observing site and process constraints presented by the site and traffic data specified in contract specific Appendix 7/1.

3 (07/19) The Contractor shall:

- (i) work in accordance with the design provided to achieve the performance requirements in terms of control of reflection cracking as set out in this Clause and in contract specific Appendix 7/1;
- (ii) ensure that the geosynthetic or steel mesh has initial bond such that it is capable of withstanding construction traffic, and remains fully adhered to the substrate and the asphalt overlay with no separation.

(07/19) **Materials and Equipment**

4 (07/21) The geosynthetic or steel mesh shall be manufactured to the requirements of BS EN 15381.

5 (07/19) The installation of the geosynthetic or steel mesh shall be carried out by a purpose built mechanical applicator where it is possible to do so. Hand-laying may be required in locations such as tight radius bends and on small restricted sites.

(07/19) **Bond Coats**

6 (07/19) Systems requiring hot bitumen bond coats for installation shall use paving grade bitumen produced in accordance with BS EN 12591 or use hot modified bitumen in accordance with BS EN 14023.

7 (07/19) Bitumen emulsion bond coats produced in accordance with BS EN 13808 may be used as an alternative to using hot bitumen.

8 (07/21) Bond coats shall be installed in accordance with the following criteria:

- (i) A bond coat shall be applied directly beneath the geosynthetic in accordance with the minimum application rates given in BS 594987. Higher application rates may be specified on a product specific basis. (Note: in some cases this bond coat may be part of a composite system including a geosynthetic.)

- (ii) The bond coat shall be sprayed through a calibrated spray bar at the agreed rate appropriate to the specific project. The calibrated spray bar shall be in good working order and shall be certified showing that it has been tested within the last twelve months to conform to BS 1707.
- (iii) The rate and accuracy of the distribution of the bond coat shall be checked at the commencement of the work by means of a carpet tile test carried out in accordance with BS EN12272-1. This test shall be repeated for each binder distributor used during the course of the work.
- (iv) Where bitumen emulsions are used, evidence shall be provided by the Contractor that the emulsion will “break” within the time limits likely to be encountered during normal maintenance working windows.
- (v) Systems requiring slurry surfacing bond coats for installation shall use a slurry surfacing system complying with the requirements in BS EN 12273.

9 (07/19) Systems requiring a levelling or regulating course shall be laid in accordance with the requirements of Clause 907.

#### (07/19) Surface Preparation

10 (07/21) The surface to receive the geosynthetic or steel mesh shall be free of surface defects so as not to compromise the performance of the product system to be applied.

11 (07/19) Before binder is applied, ironwork shall be masked. Any planings or asphalt deposits on the surface shall be removed and the receiving surface shall be swept free of all loose material.

#### (07/19) Application

12 (07/19) Installation shall be carried out using appropriate mechanical equipment that is designed specifically to lay the material under tension. Installation shall be planned and carried out such that there is continuity of works and other surfacing operations are not impeded.

13 (07/19) The Contractor’s quality plan shall determine the weather conditions under which the geosynthetic or steel mesh can be installed. Transverse and longitudinal overlaps shall be in accordance with the Contractor’s quality plan. The Contractor shall measure and record the bond condition as stipulated in the quality plan and refer to the RSTA ADEPT Code of Practice for Geosynthetics and Steel Meshes.

14 (07/19) A geosynthetic or steel mesh interlayer shall be placed sufficiently deep within the bound layers so that it is not removed when the surface course is replaced. If a surface course is to be placed directly on a geosynthetic, approval by the Overseeing Organisation (a Departure from Standard) will be needed.

#### (07/19) Aftercare

15 (07/19) Masking shall be removed after the geosynthetic or steel mesh has been installed and before the surfacing operation commences. The geosynthetic or steel mesh shall be overlaid in the same shift, or as soon as is practically possible.

16 (07/19) The Contractor shall undertake remedial action where necessary, which may include nailing, patching, cutting or dusting if there are signs of distress, such as separation, turning damage, bleeding or pickup of the geosynthetic or steel mesh in order to prevent further damage to the System.

#### (07/19) As Built Manual

17 (07/21) Not more than 30 days after completion of the work the Contractor shall provide a record of the progress of the work in the form of an ‘as built’ manual incorporating all relevant information, including:

- (i) the product name;
- (ii) all test results;

- (iii) a pre-treatment crack map. Where geosynthetics are applied over a new longitudinal joint, a drawing showing the location of the joint shall be submitted. (Note: If a pre-treatment crack map is not provided, all cracks appearing within 5 years will be seen as 'excessive' and require remedial measures (see sub-Clause 936.19).
- (iv) variations to the design proposal and those necessitated by local conditions (which need to be agreed prior to installation);
- (v) a record of installation control carried out;
- (vi) weather information;
- (vii) unforeseen problems encountered;
- (viii) a list of complaints, if any, from the general public or road users;
- (ix) any other information that the Overseeing Organisation may reasonably require to be included, as previously agreed.

Records are to be sent to Highways England using the [PavementInnovationsDevelopment@highwaysengland.co.uk](mailto:PavementInnovationsDevelopment@highwaysengland.co.uk) email address.

#### (07/19) Defects

**18** (07/19) The surface course shall not have more than 10% of the reflection cracking that was present before the installation of the geosynthetic or steel mesh, for a minimum period of 5 years. The amount of cracking shall be expressed as a length per 100m for each 100m length. The length of cracking before treatment shall be taken from the visual survey produced as part of the pavement investigation used for scheme identification.

**19** (07/19) Replacement of the surfacing or other remedial measures agreed with the Overseeing Organisation shall be carried out if reflection cracking appears within the first 5 years.

**20** (07/19) For the period of the guarantee, the geosynthetic or steel mesh shall meet the performance requirements stated in this Clause and contract specific Appendix 7/1.

**21** (07/19) The guarantee shall exclude defects arising from accidental damage or damage caused by settlement or subsidence on which the surfacing material has been laid.

**22** (07/19) The reappearance of reflection cracking shall be confirmed by comparing locations of cracking with visual survey records carried out as part of the investigation prior to maintenance treatment design and coring through the cracks. This will identify whether cracking in the 'new' surface appears over existing cracks lower in the pavement structure. Note that reflection cracking may be 'top-down' or 'bottom-up'.

### 937 (05/18) Stone Mastic Asphalt (SMA) Binder Course and Regulating Course

#### (05/18) General

**1** (05/18) Stone Mastic Asphalt binder course and regulating course shall conform to BS EN13108-5, the example from BSI PD 6691 Annex D for the selected mixture, the requirements of this Clause and those specified in contract specific Appendix 7/1. The mixture designation shall be one of the following:

- (i) SMA 6 bin 40/60.
- (ii) SMA 6 bin 70/100.
- (iii) SMA 6 bin 100/150.
- (iv) SMA 6 bin PMB.
- (v) SMA 10 bin 40/60.
- (vi) SMA 10 bin 70/100.

- (vii) SMA 10 bin 100/150.
- (viii) SMA 10 bin PMB.
- (ix) SMA 14 bin 40/60.
- (x) SMA 14 bin 70/100.
- (xi) SMA 14 bin 100/150.
- (xii) SMA 14 bin PMB.
- (xiii) SMA 20 bin 40/60.
- (xiv) SMA 20 bin 70/100.
- (xv) SMA 20 bin 100/150.
- (xvi) SMA 20 bin PMB.

(05/18) **Binder Modification**

**2** (05/18) Polymer modified bitumens shall comply with BS EN 14023. The Contractor shall provide the declaration of performance for the polymer modified bitumen to the Overseeing Organisation. The declaration of performance shall demonstrate that the binder meets the requirements of the specification including the requirements stated in contract specific Appendix 7/1.

**3** (05/18) For premixed binders not covered by BS EN 12591 or BS EN 14023 the Contractor shall provide data sheets giving details of the properties of the modified binders or additives proposed, including those specified in contract specific Appendix 7/1. These shall include rheological data for pre-blended polymer modified binders in accordance with BS EN 14770 and cohesion in accordance with BS EN 13588.

(05/18) **Deformation Resistance**

**4** (05/18) The resistance to permanent deformation of the mixture shall be in accordance with the appropriate class selected from Table D.7 of BSI PD 6691 as specified in contract specific Appendix 7/1.

**5** (05/18) When specified in contract specific Appendix 7/1 the resistance to permanent deformation of material laid in the permanent works shall be monitored by testing in accordance with BS 594987, clause G 3.1, 3.2 and 3.3. Six cores shall be taken from the first kilometre length of material from each mixing plant and thereafter one further core from each subsequent lane kilometre. Results shall be assessed on successive rolling means of sets of six consecutive results and shall be deemed to conform if the mean is no greater than the specified value and individual values not more than 50% greater than the specified value.

(05/18) **Compaction control for Permanent Works**

**6** (05/18) Compaction shall be controlled by monitoring density and air void content in accordance with BS 594987, clause 9.5.3 and the requirements of this Clause.

**7** (05/18) Density shall be continuously assessed using an indirect density gauge in accordance with BS 594987, clause 9.4.2, with readings taken at 50 m intervals in the centre of the mat. Gauge readings shall also be taken at each core location specified in BS 594987, clause 9.5.3.2.1 and at the location of cores required by sub-Clause 11. Each gauge shall be individually calibrated on each mixture from each mixing plant and the calibrations shall be continually checked and updated based on correlations between gauge readings and core densities at the same locations.

**8** (05/18) For each location, the in situ void content shall be determined in accordance with EN 12697-8 using the bulk density from the indirect gauge reading and a maximum density taken from the mixture type testing data and updated with values from testing in accordance with sub-Clause 8.

**9** (05/18) The average in situ void content calculated from any six consecutive indirect gauge readings shall not exceed 5%, or for regulating course less than 30 mm in thickness, shall not exceed 7%.

**10** (05/18) In the event of a failure to meet the requirements in sub-Clause 10, cores shall be taken at each location and void contents determined. Testing of cores shall be carried out in accordance with BS 594987 section 9.5.3 and assessment of conformity shall be in accordance with BS 594987, clause 9.5.3.6.1

**11** (05/18) In the event of non-conformity with the requirements of sub-Clause 11 then density readings with indirect gauges and if necessary, further cores shall be taken to establish the extent of the non-conformity. If it is necessary to remove and replace any material to restore conformity this shall be in lengths not less than 15 m unless otherwise agreed by the Overseeing Organisation.

**12** (05/18) If the density readings taken with the indirect density gauge indicate that the air voids content may be less than 2%, one 200 mm diameter core shall be cut at that chainage and the resistance to permanent deformation checked in accordance with sub-Clause 6.

#### (05/18) Bond Coat

**13** (05/18) Where the thickness of the stone mastic asphalt is less than 20 mm, polymer modified bond coats shall be used.

#### (07/21) Warm Mix Asphalt (WMA)

**14** (07/21) Mixtures to be produced as WMAs shall comply with Clause 908.

### **938** (05/18) Porous Asphalt

**1** (05/18) Porous asphalt shall conform to BS EN 13108-7, as specified in contract specific Appendix 7/1.

### **939 to 941** (05/18) Not Used

### **#942** (05/18) Thin Surface Course Systems

#### (05/18) General

**1** (05/18) Thin surface course systems shall be provided and installed in accordance with the requirements stated in this Clause and those given in contract specific Appendix 7/1.

**2** (05/18) Thin surface course systems specified under this Clause shall be between 20mm and 50mm thick.

#### (05/18) Overall Performance Requirements

**3** (05/18) The Contractor shall guarantee the installed thin surface course for a period of 5 years from the date of opening to traffic. For the period of the guarantee the thin surface course shall meet the performance requirements stated in this Clause and contract specific Appendix 7/1. The guarantee shall exclude defects arising from accidental damage or damage caused by settlement, subsidence or failure of the underlying carriageway on which the surfacing material has been laid. Replacement of the surfacing or other remedial measures agreed with the Overseeing Organisation shall be executed if the surfacing is in a "Suspect", "Poor" or "Bad" condition as defined in Appendix A of TRL Report TRL674 – "Durability of thin surfacing systems, Part 4, Final report after nine years monitoring, TRL report 674".

**4** (05/18) The Contractor shall demonstrate that the 'as installed' thin surface course system can meet the requirements of the specification. This shall be demonstrated by the system meeting the stated material requirements and by having undergone a System Installation Performance Trial (SIPT) to cover the aspects of the installation not covered by the material's declaration of performance. The SIPT shall comply with the requirements of sub-Clauses 23 to 43 of this Clause. An acceptable approach for the SIPT would be to use a scheme in accordance with sub-Clause 104.16. The Contractor shall submit details of the SIPT for the systems to be used in the contract as required in sub-Clause 28 to the Overseeing Organisation for acceptance.

(05/18) **Material Requirements**

**5** (05/18) The thin surface course mixture shall comply with BS EN 13108-1, BS EN 13108-2 or BS EN 13108-5. It shall be CE marked and the Contractor shall submit the declaration of performance for the material to the Overseeing Organisation. The declaration of performance shall demonstrate that the material meets the requirements of the specification.

**6** (05/18) The coarse aggregate shall be crushed rock or steel slag complying with Clause 901 and BS EN 13043:2002. The Contractor shall submit the declaration of performance for the aggregate to the Overseeing Organisation. The declaration of performance shall demonstrate that the aggregate meets the requirements of the specification. The resistance to polishing and abrasion, PSV and AAV, shall be as specified in contract specific Appendix 7/1.

The aggregate resistance to fragmentation and flakiness Index shall be as follows:

- (i) Resistance to fragmentation: Los Angeles Coefficient (LA) – not greater than LA<sub>30</sub>;
- (ii) Flakiness Index (FI) – not greater than FI<sub>20</sub>.

The maximum aggregate size shall be as given in Table 9/9

**TABLE 9/9:** (05/18) **Maximum Aggregate Size**

Site Definition	Maximum Aggregate Size
Roundabouts	10mm
Bends < 250m radius	10mm
Junctions where turning radius movements <250m	10mm
All other sites	14mm

**7** (05/18) The minimum target design binder contents shall be in accordance with Table 9/10 and contract specific Appendix 7/1.

**TABLE 9/10:** (05/18) **Minimum design binder content**

Maximum aggregate size (D)	Minimum target design binder content (B <sub>min</sub> )	
	Mixture types: EN13108, Parts 1 and 2 (AC & BBTM with PMB to BS EN 14023)	Mixture types: EN 13108 Part 5 (SMA – paving grade bitumen to BS EN 12591 and fibresSMA)
14	5.0	6.0
10	5.2	6.2
6	5.4	Not used

**8** (05/18) The resistance to permanent deformation shall be as specified in contract specific Appendix 7/1. The resistance to permanent deformation of mixtures conforming to BS EN 13108 Parts 1 and 5 shall be in accordance with the appropriate class selected from Table B.4 or D.2 respectively of PD 6691.

**9** (05/18) The water sensitivity shall be as specified in contract specific Appendix 7/1. The water sensitivity of mixtures conforming with BS EN 13108 Parts 1, 2 and 5 shall conform to, at least, category ITSR<sub>min</sub>70.

**10** (05/18) Where required in contract specific Appendix 7/1 the design void content shall be V<sub>min</sub> 1 to V<sub>max</sub> 5%

**11** (05/18) Contract compliance testing of the mixture shall be carried out as required in contract specific Appendix 1/5 and samples supplied as detailed in contract specific Appendix 1/6.

(05/18) **Installation Requirements: General**

**12** (05/18) The Contractor shall provide an Installation Method Statement to the Overseeing Organisation. It shall include the SIPT method statement as described in sub-Clause 26 of this Clause, all installation instructions relevant to the system being used, details as specified in this Clause and details to meet the requirements of Clause 903.

**13** (05/18) The design thickness of the thin surface course system shall be as specified in the contract specific Appendix 7/1 within the minimum and maximum design thickness permitted in Table 9/11. The installed layer thickness must not be less than the permitted minimum thickness, nor greater than the permitted maximum thickness, stated in the Installation Method Statement.

**TABLE 9/11: (05/18) Design Target Layer Thickness.**

Nominal Aggregate size, mm	Design target thickness, mm	
	Minimum	Maximum
6	20	30
10	25	40
14	35	50

**14** (05/18) Where required in the Installation Method Statement or in contract specific Appendix 7/1, to achieve final pavement levels and/or thicknesses the existing substrate surface shall be strengthened or regulated in accordance with Clause 907.

**15** (05/18) Where the existing substrate surface is regulated in accordance with Clause 907, evidence that the deformation resistance of the regulating material will meet the specification shall be submitted by the Contractor to the Overseeing Organisation. Where the combined thickness of the regulating material and the thin surface course is more than 20 mm, evidence of the deformation resistance of the combined layers shall be provided.

**16** (05/18) Surface preparation including the removal of road markings, cleaning and drying, resetting of ironwork and road studs shall be in accordance with BS 594987 and the Installation Method Statement.

**17** (05/18) Where required in the Installation Method Statement a bond coat or tack coat shall be applied. It shall be in accordance with the Installation Method Statement. Unless otherwise stated in the Installation Method Statement is shall also comply with Clause 920 and BS 594987. A calibrated mechanised method of application shall be used unless otherwise agreed with the Overseeing Organisation.

**18** (05/18) Transportation of the thin surface course material shall be in accordance with the System Installation Method Statement and Clause 903.

(05/18) **Installation Requirements: Surface Macrotexture – Untrafficked**

**19** (05/18) The surface macrotexture depth of the thin surface course system shall be measured in accordance with BS EN 13036-1. Unless otherwise stated in contract specific Appendix 7/1 the macrotexture of the installed surfacing shall comply with the relevant section of Table 9/12 or Table 9/13.

**TABLE 9/12: (05/18) Requirements for Initial Texture Depth for Trunk Roads including Motorways for Thin Surface Course Systems**

Road Type	Surfacing Type	Average per 1,000 m section, mm		Average for a set of 10 Measurements, mm (minimum)
		Minimum	Maximum	
High speed roads	Upper (D) aggregate size of 14mm	1.3	1.8	1.0
	Upper (D) aggregate size of 10mm	1.1	1.6	0.9
	Upper (D) aggregate size of 6mm	1.0	1.5	0.9
Lower speed roads	Upper (D) aggregate size of 14mm or less:	1.0	1.5	0.9
Roundabouts on high speed roads	Upper (D) aggregate size of 10mm	1.1	1.6	0.9
Roundabouts on lower speed roads	Upper (D) aggregate size of 10mm	1.0	1.5	0.9
	Upper (D) aggregate size of 6mm	1.0	1.5	0.9

High Speed Roads are those with a posted speed limit  $\geq 50$  miles/h (80 km/h)

Lower Speed Roads are those with a posted speed limit  $\leq 40$  miles/h (65 km/h)

**TABLE 9/13: (05/18) Requirements for Initial Texture Depth for Roads other than Trunk Roads and Motorways for Thin Surface Course Systems**

Road Classification	Posted traffic speed	Average per 1,000 m section, mm		Average for a set of 10 Measurements, mm (minimum)
		Minimum initial (mm)	Maximum Initial (mm)	
A	$\geq 50$ mph	1.0	1.5	0.9
A	All other traffic speeds	0.8	1.3	0.7
B,C,U	All traffic speeds	0.8	1.3	0.7

**(05/18) Installation Requirements: Macrotexture – Trafficked**

**20** (05/18) For a period of two years from the date of opening to traffic the average macrotexture, measured using the volumetric patch technique in accordance with BS EN 13036-1, will be maintained above the levels given in contract specific Appendix 7/1 and Table 9/14. The measurements shall be in the most heavily trafficked lane at 10 m intervals along the centre of the most heavily worn wheel-track.

**TABLE 9/14: (05/18) Retained Surface Macrotexture Requirements**

Surfacing Type	Average texture depth per 1,000m section, mm*
Systems with an upper (D) aggregate size of 14mm laid on motorway trunk and high speed A roads	0.9
Systems with an upper (D) aggregate size of 10mm laid on motorway trunk and high speed A roads	0.8
Systems with an upper (D) aggregate size of 6mm laid on motorway trunk and high speed A roads	0.7 **
Systems with all aggregate sizes laid on non-trunk low speed A, and all B, C and U classification roads	0.6

\* or the complete carriageway lane where this is less than 1,000 m.

\*\* verification of high speed friction performance required

**(05/18) Installation Requirements: Torque Bond**

**21** (05/18) The bond strength between a thin surfacing system and its substrate shall be  $\geq 400$  kPa, measured in accordance with Clause 951.

**(05/18) Installation Requirements: Noise**

**22** (05/18) The thin surface course system shall have the road/tyre noise characteristics as required in contract specific Appendix 7/1.

**(05/18) System Installation Performance Trial (SIPT) Requirements**

**23** (05/18) The thin surface course used in the SIPT shall meet the performance requirements of the thin surface course to be supplied under the contract. This shall be demonstrated by the assessments and testing undertaken for the SIPT.

**24** (05/18) The installed thin surface course system shall be assessed, tested and certified by a Certification Body using one or more trial areas of surfacing. The Certification Body shall be accredited to BS EN 45011 by UKAS or equivalent European Accreditation organisation which is party to a multi-lateral agreement (MLA) with UKAS or any equivalent International Accreditation Forum MLA signatory with a scope that includes relevant standard(s) or scheme(s).

**25** (05/18) The area of surfacing for the SIPT shall be a minimum of 200 metres in length and 3.5 metres in width.

**26** (05/18) A SIPT method statement shall be prepared. The SIPT shall demonstrate, and enable verification of, the installation procedures given in the SIPT method statement. This will include the correct application rates of the bond (or tack) coat, application method of bond coat, paving speed of mixed material, joint formation, laying temperatures, methods of verification to be used on site, maintenance and repair techniques, aftercare, and frequency of testing and acceptable variations within the specified limits.

**27** (05/18) A SIPT inspection protocol shall be prepared. It shall demonstrate qualitatively and quantitatively the applicability of the SIPT for the system in order to satisfy the performance requirements.

**28** (05/18) The SIPT method statement, SIPT inspection protocols, all inspection and testing results and the SIPT certification shall be submitted to the Overseeing Organisation along with the Installation Method Statement.

**29** (05/18) The SIPT shall include the following to be undertaken by the Certification Body:

- (i) verification that the system installation trial has been undertaken in accordance with the SIPT method statement and the stated protocols;
- (ii) assessment of the visual condition of the completed system at the times stated in sub-Clause 30;
- (iii) assessment of the data from the site performance tests detailed in sub-Clause 30.

The assessments shall be undertaken by an assessment team that includes a lead assessor with experience in pavement inspections and a minimum of two additional suitably experienced persons to comprise an inspection panel for the visual condition of the SIPT installation and interim inspections.

**30** (05/18) The installed performance characteristics of the trial area shall meet the criteria stated in Table 9/15 at the times and intervals stated.

**TABLE 9/15:** (05/18) **Installed Performance characteristics**

Characteristic	Performance Requirements	Time(s) at which the performance characteristic shall be determined or measured
Visual inspection As defined in sub-Clause 32	Good or Excellent	At opening to traffic.
	Good or Excellent	12 months after opening to traffic.
	Good or Excellent	24 months after opening to traffic
Surface macrotexture depth (BS EN 13036-1:2010)	Contract specific Appendix 7/1 or Table 9/12 or 9/13	At opening to traffic.
	Appendix 7/1 and Table 9/14	12 months after opening to traffic.
	Appendix 7/1 and Table 9/14	24 months after opening to traffic
Torque Bond	≥ 400 kPa	Between 28 and 56 days after installation.
Road/Tyre Noise level	Table 9/17	Between 12 and 24 months after opening to traffic.
Void Content (Voluntary assessment and declaration)	Sub-Clause 34	Between 0 and 24 months after opening to traffic.

**31** (05/18) Defects identified during the visual inspections shall be recorded. The defects to be recorded are those described in TRL 674. The assessment of defects shall be summarised as a Performance Band as listed in Table 9/16.

**TABLE 9/16:** (05/18) **Site Installation Performance Trial visual inspection requirement**

Performance Band	Description
Excellent	No discernible fault
Good	No significant fault
Moderate	Some defects but insufficient for serious problem
Acceptable	Several defects but would usually be just acceptable
Suspect	Seriously defective but still serviceable in the short term
Poor	Requires remedial treatment
Bad	Requires immediate remedial treatment

**32** (05/18) The torque bond strength between the thin surface course and its substrate shall be established in accordance with Clause 951. This shall be established between 28 and 56 days after the SIPT is installed.

**33** (05/18) The void content of the proposed mixture when evaluated for the SIPT shall be  $V_{min} - 2$  to  $V_{max} + 6\%$  from the average of 6 cores.

(05/18) Noise

**34** (05/18) Where noise characteristics for the thin surface course systems are specified in contract specific Appendix 7/1 the SIPT shall include the assessment and measurement of noise characteristics as described in sub-Clauses 34 to 43 of this Clause. The declared level shall be 0 to 3 or 'NR' as given in Table 9/17.

**TABLE 9/17:** (05/18) Road/Tyre Noise Levels

Level	Equivalence to Traditional Surfacing Materials	Road Surface Influence RSI
3	Very quiet surfacing material	-3.5 dB(A)
2	Quieter than HRA surfacing materials	-2.5 dB(A)
1	Equivalent to HRA surfacing materials	-0.5 dB(A)
0	Noisier than HRA Surfacing Materials	+1.2 dB(A)
NR	No requirement	No requirement

**35** (05/18) The influence of the road surface on traffic noise using the statistical pass-by method shall be established at the SIPT site between 12 and 24 months after opening to traffic in accordance with ISO 11819-1: 2002, Sections 7 and 8.

**36** (05/18) Acoustic measurements shall only be carried out when the road surface is dry and the meteorological condition specified in ISO 11819-1: 2002, Section 11 are met.

**37** (05/18) The air and surface temperatures shall be monitored in accordance with the procedure described in ISO 11819-1: 2002, clause 8.5. The road surface temperature,  $T_{\text{surface}}$ , must be within 5°C to 50°C during acoustic measurements. The air temperature,  $T_{\text{air}}$ , must be within 5°C to 30°C.

**38** (05/18) The test location road speed category shall be classified as either Medium or High as defined in ISO 11819-1: 2002, clause 3.3. Not less than two test locations shall be selected for each road speed category, which may be at the same site, provided the locations are at least 100 m apart or on different carriageways. Each test location shall be representative in terms of road speed category and traffic level. Each of the test sites selected must meet the requirements of ISO 11819-1: 2002 Section 6 and ISO/CD 11819-2: 2000. The road must be essentially straight, or bends with a radius of curvature greater than 500 m for medium-speed, and 1000 m for high-speed road categories. The crossfall of the test lane at the test site must not exceed 4%.

**39** (05/18) The apparatus described in ISO 11819-1: 2002 Section 5 are used. The frequency range of between 100 and 5000 Hz (centre frequencies of the one-third octave bands) should be covered.

**40** (05/18) The macrotexture of the road surface used for the noise assessment shall be measured in the nearside wheel-track along the whole length of test material in accordance BS EN 13036-1:2010. The macrotexture depth of the nearside wheel-track in front of a test location must be within 10 per cent of the average macrotexture measured along the site.

**41** (05/18) The microphone location at each measurement site shall be recorded accurately and marked with appropriate methods such that the position can be readily identified for a period of at least two years.

**42** (05/18) When sufficient vehicle pass-bys have been measured, a linear regression analysis shall be performed in accordance with ISO 11819-1: 2002, clause 9.1. In the case of the high-speed road category, measurements must not be taken of vehicles travelling at speeds of less than 60 km/h in accordance with AFNOR Standard S31-119.

**43** (05/18) For each category of vehicle defined in Table 9/18, the Vehicle Sound Level,  $L_{\text{veh}}$ , shall be calculated as the ordinate sound level of the regression line at the reference speed for the category of road. All levels shall be calculated to two decimal places and rounded to one decimal place.

**TABLE 9/18:** (05/18) **Reference speeds (km•h-1) for different road speed categories**

Vehicle category	Road speed category (km•h-1)	
	Medium	High
L	80	110
H1	70	90
H2	70	90

Category L vehicles — light vehicles including passenger cars and car derived vans, excluding vehicles towing trailers.

Category H1 vehicles — commercial trucks with 2 axles and greater than 3.5 tonnes.

Category H2 vehicles — commercial trucks with more than 2 axles and greater than 3.5 tonnes.

(07/21) **Warm Mix Asphalt (WMA)**

**44** (07/21) Mixtures to be produced as WMAs shall comply with the requirements of this Clause and Clause 908.

**943** (05/18) **Hot Rolled Asphalt Surface Course and Binder Course (Performance-Related Design Mixtures)**

**1** (05/18) HRA Performance Related surface course shall conform to BS EN 13108-4 and follow the example from BSI PD 6691 Annex C section C.2.5.1.4, the requirements of this Clause and those specified in contract specific Appendix 7.1.

This mixture can be laid at lower layers within special pavement types, e.g bridge decks, when it is unchipped.

(05/18) **Layer Thickness**

**2** (05/18) The nominal thickness of the hot rolled asphalt surface course layer shall be either 45 mm or 50 mm unless otherwise specified in contract specific Appendix 7/1.

(05/18) **Binder and Binder Modification**

**3** (05/18) Bitumen processed during refining to provide a binder with enhanced properties without the addition of a modifier, shall have a HAPAS certificate or equivalent product acceptance scheme certification.

**4** (05/18) For binders that do not comply with Clause 901 and without HAPAS or equivalent product acceptance scheme certification, the Contractor shall provide data sheets giving details of the properties of modified binders, whether the modifier is pre-blended with bitumen, the bitumen is modified during refinery processing or modified by addition into the asphalt mixer, including those specified in contract specific Appendix 7/1. These shall include rheological data in accordance with BS EN 14770 and cohesion in accordance with BS EN 13588. Binders that do not comply with Clause 901 or sub-Clause 3 of this Clause shall not be used without the approval of the Overseeing Organisation.

(05/18) **Coarse Aggregate**

**5** (05/18) Coarse aggregate shall be crushed rock or slag complying with BS EN 13043:2002 and Clause 901. The resistance to polishing of the coarse aggregate for surface course shall comply with category  $PSV_{44}$  in accordance with BS EN 13043:2002, clause 4.2.3.

(05/18) **Deformation Resistance**

**6** (05/18) The resistance to permanent deformation of the mixture shall be in accordance with the appropriate class selected from Table C.3 of BSI PD 6691, as specified in contract specific Appendix 7/1.

(05/18) **Coated Chippings for Surface Course**

7 (05/18) When required, coated chippings shall be 14/20 mm or 8/14 mm size as specified in contract specific Appendix 7/1 and comply with Clause 915.

(05/18) **Surface Macrotexture for Surface Course**

8 (05/18) The surface macrotexture shall comply with Clause 921.

(05/18) **Compaction Control Procedures**

9 (05/18) Control testing for compaction and resistance to permanent deformation shall be carried out in accordance with BS 594987 section 9.5.2.

10 (05/18) When specified in the contract specific Appendix 7/1, the resistance to permanent deformation of material laid in the permanent works shall be monitored by testing in accordance with clause F.3 of BS 594987 Annex F. Six cores shall be taken from the first kilometre length of material from each mixing plant and thereafter one further core from each subsequent lane kilometre. Results shall be assessed on successive rolling means of sets of six consecutive results and shall be deemed to conform if the mean is no greater than the specified value and individual values not more than 50% greater than the specified value.

(05/18) **Trafficking Newly Laid Surfacing**

11 (05/18) The Contractor shall ensure the pavement material has adequately cooled and hardened before the road is opened to traffic. Unless otherwise agreed by the Overseeing Organisation, the road shall not be opened to traffic if its surface temperature exceeds 25°C unless the maximum temperature within the mat has fallen below 35°C.

**944 (05/18) Not Used**

**945 (05/18) Weather Conditions for Laying of Hot Bituminous Mixtures**

1 (05/18) The Contractor shall take account of the weather conditions when planning his working methods. The Contractor's working methods shall comply with all weather-related requirements of BS 594987 and any additional requirements of this Clause. When laying is to be undertaken during winter (October to April) and/or night time (9 p.m. to 6 a.m.), the contractor shall work to a Quality Plan that allows for the specific issues raised by winter and/or night time working.

2 (05/18) Hot bituminous materials laid less than 50 mm thick, other than those supplied to Clause 942, shall be laid within the wind speed and temperature constraints of Figure 9/1.

(05/18) **Thin Surface Course Systems**

3 (05/18) The weather conditions for laying thin surface course systems shall comply with those identified as being acceptable in the Installation Method Statement as required in Clause 942.

(05/18) **Hot Rolled Asphalt With Pre-coated Chippings**

4 (05/18) Hot rolled asphalt surface course mixtures incorporating 35% coarse aggregate with pre-coated chippings shall be laid 50 mm thick, within the following constraints of delivery temperature, wind speed and air temperature.

Air temperature (minimum):	0°C
Wind speed (maximum at any air temperature):	40 km/h (at 2 m height) or 50 km/h (at 10 m height)
Minimum delivery temperature of materials:	155°C

(05/18) **Wind Speed**

5 (05/18) When measurements are required for assessment, wind speed shall be measured by anemometer positioned near the laying site to accurately reflect conditions at the laying site. The anemometer shall be fitted with a digital accumulative device.

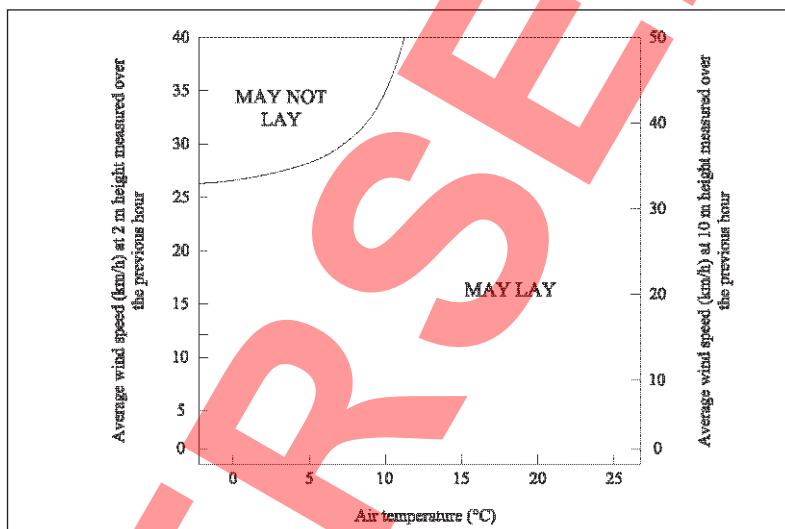

**FIGURE 9/1: (05/18) Wind Speed and Air Temperature Laying Restrictions for Layers Less Than 50 mm Thick**

**946 (05/18) Local Repairs**

(05/18) **General**

- (05/18) Local repair is defined as the reinstatement of surface course, and binder course and base if necessary, over a relatively small area.
- (05/18) Areas of defectiveness greater than 1m<sup>2</sup> shall be repaired by inset replacement over a length and width in accordance with sub-Clause 702.10(iv) and sub-Clause 903.21. Areas of defectiveness up to 1m<sup>2</sup> in surface area may be repaired using an inset patch. The repair technique used shall be as given in Table 9/19.

**TABLE 9/19: (05/18) Repair Technique**

Size ( approx m <sup>2</sup> )	Application	Repair technique
Up to 1.0	Individual pothole or road stud hole. Discrete area of local defectiveness	Inset patch
In excess of 1.0 or several closely adjacent areas less than 1.0	Wide area of local defectiveness.	Replacement for minimum length of 5m or 15m in accordance with sub-Clause 702.10 (iv). Full lane width or less where practicable, joints to comply with sub-Clause 903.21.

**(05/18) Inset Patch Repair for Areas ≤ 1.0m<sup>2</sup> – Preparation**

**3** (05/18) The edges of the repair shall be saw-cut or planed in a neat rectangular shape in sound surfacing at a distance of at least 0.25m beyond the defective area. The saw-cut or planed opening shall have vertical straight edges and extend for the full depth of surface course. For repairs that extend into the binder course and/or base these lower layers may be removed by the use of a mechanical breaker. An offset stepped detail for the binder and base layers shall be used to ensure that vertical joints do not pass through more than one layer at the same location. A minimum horizontal step of 100mm shall be provided at all layer interfaces.

**4** (05/18) All existing material within the saw-cut perimeter of the repair area shall be removed and the base and sides of the cavity thoroughly cleansed of all loose material and moisture to provide clean and dry surfaces throughout.

**5** The prepared vertical joints and the base of the cavity shall be treated in accordance with sub-Clause 903.22.

**(05/18) Inset Patch Repair for Areas ≤ 1.0m<sup>2</sup> – Repair Materials**

**6** (05/18) Repair materials shall comply with the specification requirements stated in contract specific Appendix 7/1. Unless otherwise stated in contract specific Appendix 7/1 repair materials shall be consistent with, and compatible to, the surrounding materials.

**7** (05/18) Repair materials for patches in hot rolled asphalt surfacing shall be in accordance with Clause 911.

**(05/18) Inset Patch Repair for Areas ≤ 1.0m<sup>2</sup> – Construction**

**8** (05/18) Construction of the repair should commence at the edges and progress inwards with particular care for full compaction especially in the vicinity of the vertical joint faces. All construction layers shall be laid and compacted such that on completion each layer shall be at the same level as the adjacent course.

**9** (05/18) The repair material must be compacted using rollers, vibrating plates and/or tampers as appropriate for the size of the repair. The corners of the repair are the most vulnerable to distress and particular care must be taken to achieve full compaction in these areas.

**(05/18) Repair Areas >1.0m<sup>2</sup>**

**10** (05/18) Large areas shall only be repaired with materials installed using full scale self-propelled paving machinery. The extent of the repair area shall be as described in sub-Clause 702.10(iv) with appropriate longitudinal and transverse joints in accordance with sub-Clause 903.21.

**11** (05/18) Repairs to large areas in Thin Surface Course Systems shall be undertaken in accordance with the instructions stated in contract specific Appendix 7/1.

**12** (05/18) Repair materials shall comply with the specification requirements stated in contract specific Appendix 7/1. Unless otherwise stated in contract specific Appendix 7/1 repair materials shall be consistent with, and compatible to, the surrounding materials.

**13** (05/18) Areas exceeding 1m<sup>2</sup> in existing hot rolled asphalt surfacing shall be repaired using hot rolled asphalt material in accordance with Clause 911.

14 (05/18) Placing and compaction shall be in accordance with Clause 903 and BS594987 with use of bond coat in accordance with Clause 920.

(05/18) **Proprietary Materials and Techniques for Repairs  $\leq 1.0\text{m}^2$**

15 (05/18) Evidence from laboratory evaluation shall be provided by the Contractor to the Overseeing Organisation to demonstrate that the proprietary repair materials and/or techniques comply with the following performance criteria:

- Stiffness:  $\geq 1$  GPa after 28 days when tested in accordance with BS EN 12697-26 (ITSM method 20°C)
- Resistance to permanent deformation: Classification No. 1 as defined in Table D.2 of BSI PD 6691

16 (05/18) Data from a representative area of the material and/or technique, for a local repair  $>2\text{m}^2$  in size, must be provided to demonstrate that the finished surface to be trafficked complies with the following:

- The initial surface texture shall be not less than 0.9mm when measured using the volumetric patch method described in BS EN 13036-1
- The minimum wet Skid Resistance value shall not be less than 60 when determined using the portable skid resistance tester (pendulum) in accordance with BS EN 13036-4.

## 947 (05/18) In Situ Cold Recycled Bitumen Bound Material

(05/18) **Scope**

1 (05/18) In situ cold recycled bitumen bound material shall be designed and produced to form the foundation or main structural layer of the road pavement. The primary aggregate source shall be obtained by cold pulverisation of all, or part, of the existing road structure. The primary binder (stabilising agent) shall be a foamed bitumen, with cement or lime as an adhesion agent. The aggregate grading may be adjusted by the addition of a filler. Lime may also be used to modify any cohesive sub-grade soil incorporated in the pulverised layer.

2 (05/18) Prior to commencing the pulverisation and stabilisation works, the Contractor shall demonstrate, to the satisfaction of the Overseeing Organisation, using the results of mix design procedures described in sub-Clauses 58 to 65 of this Clause, that the existing pavement materials in the sections of the works defined in contract specific Appendix 7/18 are capable of being recycled by pulverisation to form the primary aggregate component of an in situ cold recycled bitumen bound material which can meet the specified end-product performance requirements.

(05/18) **Component Materials**

(05/18) **Aggregates and Fillers**

3 (05/18) The pulverised pavement material and any supplementary aggregate and/or filler shall normally be granular material with not less than 5% and not more than 20% passing the 0.063 mm sieve (Zone A graded material). Approval for use of pulverised granular material containing up to 35% passing the 0.063 mm sieve (Zone B graded material) shall require confirmation by the Overseeing Organisation, subject to the results of the mixture design procedures described in sub-Clauses 58 to 65 of this Clause.

4 (05/18) The pulverised granular material shall contain not more than 2% of organic matter as determined in accordance with BS 1377-3 clause 3.

(05/18) **Bitumen Binder**

5 (05/18) The primary binder shall be foamed bitumen. The base bitumen shall comply with BS EN 12591 and shall be 100/150 penetration grade.

6 (05/18) Other than foaming agent(s), bitumen modifiers shall not be used unless approved by the Overseeing Organisation for special purposes or conditions.

7 (05/18) The binder shall be transported to the site in tankers capable of maintaining the required temperature and a homogeneous binder consistency and transferred to the stabilising plant in a controlled and uniform manner.

8 (05/18) The foaming of the bitumen shall be carried out within the spraybar system of the recycling machine and immediately mixed with the pulverised aggregate, at which point the foamed bitumen shall have a volume of not less than 10 times the volume of the base penetration grade bitumen.

(05/18) **Cement, Filler Aggregate and Lime**

9 (05/18) The constituents and required quality standards of hydraulic cement, filler aggregate and lime delivered to site shall be certified by the supplier, whose manufacturing and delivery processes shall be implemented using quality management systems in accordance with the BS EN ISO 9001 and certified by an accredited body.

10 (05/18) Hydraulic cement as a filler aggregate or adhesion agent shall be cement, blast furnace slag cement or PFA cement, in accordance with sub-Clause 1001.3.

11 (05/18) PFA, used as a filler aggregate, shall be in accordance with BS EN 450-1.

12 (05/18) Lime for lime stabilisation (or as a modifier for plastic fines) shall, as required in contract specific Appendix 7/18, be either quicklime or hydrated lime, complying with sub-Clause 615.3.

(05/18) **Water**

13 (05/18) Water for moisture content control of the pulverised granular material, shall normally be obtained from a water company supply and used without testing. Water from an alternative source shall comply with BS EN 1008 and be approved by the Overseeing Organisation.

(05/18) **Pulverisation and Stabilisation**

14 (05/18) The Contractor shall satisfy the Overseeing Organisation that the plant used for pulverisation is capable of uniformly pulverising the existing road structure in a single pass, to the depth stated in contract specific Appendix 7/18. The plant used for stabilisation shall be capable of uniformly mixing controlled amounts of water and binder agent(s) into the full depth of pulverised layer. For either operation, the plant shall be equipped with a means of controlling the depth of processing to  $\pm 15$  mm of the required depth.

15 (05/18) The plant used for stabilisation shall be equipped with a spraybar system within the mixing chamber capable of producing and uniformly distributing foamed bitumen binder at a monitored and controlled rate. An accessible sampling jet shall also be fitted that produces foamed bitumen having the same characteristics as that produced by the main spraybar. Flow rate meters for measuring the supply rate of hot bitumen and other liquid additives to the mixture shall be capable of recording the correct rate of flow during all states of pipeline flow (i.e. fully or partially charged). Evidence confirming the capabilities of the plant and the calibration of flow meters, shall be submitted to and approved by the Overseeing Organisation prior to the stabilisation works commencing.

16 (05/18) The material shall be pulverised and stabilised in a single layer if its compacted thickness is 300 mm or less. If the compacted thickness is greater than 300 mm, the material shall be pulverised and stabilised in the minimum number of layers between 100 mm and 300 mm thick. Where more than one layer is required, the Contractor shall satisfy the Overseeing Organisation that the lower layer has achieved adequate stability in accordance with sub-Clause 31 of this Clause before proceeding with the overlying layer.

(05/18) **Pulverisation Process**

17 (05/18) Pulverisation of the existing road structure shall be carried out in a systematic pattern, to the required depth, to ensure that all parts of the existing road designated in contract specific Appendix 7/18 are included in the works. An overlap of at least 150 mm shall be made between adjacent passes of the machine. Any material missed along hard edges or around obstructions shall be excavated and placed in the path of subsequent passes of the machine until a uniform fully pulverised aggregate is obtained. The pulverised material shall not be contaminated by material drawn in from the verges.

**18** (05/18) All longitudinal and transverse joints shall be clean cut and vertical. Where work continues adjacent to previously recycled material, transverse joints shall be reformed a minimum 0.5 m into the previously treated construction. Where a layer of material for stabilisation is placed over a layer previously stabilised, the depth of pulverisation/stabilisation of the upper layer shall be set to cut into the underlying stabilised layer by at least 20 mm.

**19** (05/18) Excess pulverised material shall be removed by the grader and/or excavator for use elsewhere on site or transported to stockpile at locations given in contract specific Appendix 7/18. The surface of the layer shall be graded nominally to the required profile and provisionally compacted.

**20** (05/18) Moisture content of the pulverised aggregate immediately prior to stabilisation shall be measured in accordance with BS EN 1097-5 using the high temperature method. The moisture content shall be uniform throughout the layer within the range  $\pm 2\%$  of the optimum moisture content for the unstabilised aggregate including any designed proportion of filler, determined in accordance with BS EN 13286-2.

**21** (05/18) If the moisture content of the unstabilised pulverised aggregate fails to meet the specified moisture content range, corrective action shall be taken either by aeration to reduce the moisture content or by controlled addition of water to increase the moisture content.

**22** (05/18) Aeration of the affected area shall be achieved by full depth passes of the recycling machine to disturb and loosen the material and assist the evaporation of excess moisture. The material shall be kept in a loose condition until subsequent moisture content tests show that the treated material has reached the required moisture content range. The layer shall be re-graded nominally to the required profile and provisionally compacted in preparation for stabilisation.

**23** (05/18) An increase in moisture content of the affected area shall be achieved by the addition of water through an adjustable spraybar system in conjunction with full depth passes of the recycling machine to achieve a uniform distribution of the water throughout the layer. Increments of water shall be added and mixed in until subsequent moisture content tests show that the material has reached the required moisture content range. The layer shall be re-graded nominally to the required profile and provisionally compacted in preparation for stabilisation.

#### (05/18) **Stabilisation Process**

**24** (05/18) Stabilisation shall not be carried out during or after periods of rainfall where the duration and intensity are likely to cause the stabilised mixture to exceed the specified moisture content criteria and compromise the stability of the layer under compaction (as defined in sub-Clause 31 of this Clause). Stabilisation of frozen materials shall not be permitted.

**25** (05/18) Prior to stabilisation, pulverised materials within 100 mm of restricted hard edges such as kerbs and channels, or around obstructions such as gullies, shall be removed and spread uniformly over the remaining full width of the pulverised material.

**26** (05/18) Immediately prior to stabilisation, any filler and/or adhesion agent shall be spread uniformly over the full width of the layer using a mechanical spreader capable of distributing the material(s) in a uniform controlled manner. The rate of spread of these materials shall be calculated to achieve the mixture composition determined in accordance with sub-Clauses 58 to 65 of this Clause and monitored as the spreading operation proceeds in accordance with sub-Clause 35 of this Clause.

**27** (05/18) The stabilisation shall be carried out to the required depth in a systematic pattern similar to that used for the pulverisation process, with an overlap of at least 150 mm between adjacent passes of the machine. The bitumen binder shall be introduced as a foamed bitumen and distributed through the spraybar system directly into the rotor and mixing box of the stabiliser. The binder shall be supplied to the spraybar of the recycling machine by pumped pipeline from on-board tanks or from a tanker moving in tandem with the recycling machine. The rate of supply of the bitumen and any foaming agent, calculated to achieve the target binder content determined in accordance with sub-Clauses 58 to 65, shall be controlled and monitored as described in sub-Clause 36 of this Clause.

**28** (05/18) The layer of stabilised material shall be graded to level and compacted within two hours of the final pass of the stabilising plant, unless a curing or “maturing” period of aeration is required. Any furrow formed by prior excavation of edge materials shall be re-filled by grading the adjacent stabilised material into the space using a minimum amount of re-working.

**29** (05/18) The compaction of each layer shall be carried out using compaction plant approved by the Overseeing Organisation, until such time as the in-situ density complies with sub-Clauses 40 and 41 of this Clause and the stabilised layer provides a stable and dense surface. Any open or segregated surface area shall be blinded using dry crushed rock fines.

**30** (05/18) The stability of the layer under compaction shall be deemed adequate if the finished surface does not shove, rut or exhibit transverse cracking under the load of subsequent construction traffic.

**31** (05/18) Where required by the Overseeing Organisation the stability of a layer in any area shall be assessed after a curing period of at least 24 hours by channelled trafficking using a rigid three-axle tipper truck loaded to a gross mass of 24 tonnes (assumed equivalent to three standard axles). The vertical deformation shall be measured in all wheel-tracks at monitoring points on each of 5 transverse sections set 1 m apart after 5, 15, 30 and 40 passes of the truck. The mean vertical deformations at the above trafficking increments shall be plotted against the respective number of truck passes and the mean vertical deformation corresponding to 100 standard axles shall be interpolated. The layer shall be deemed acceptable if the mean vertical deformation corresponding to 100 standard axles is less than 10 mm.

**32** (05/18) On completion of compaction the surface shall be sealed using a sprayed membrane of Class K1–70 bitumen emulsion complying with Clause 920. The bitumen emulsion shall be sprayed at the rate stated in contract specific Appendix 7/18. Where the surface is opened to traffic, the sealing membrane shall be blinded with fine aggregate or sand applied at a rate of 5.5 to 7.0 kg/m<sup>2</sup>.

#### (05/18) Process Control

**33** (05/18) The condition or quality of the pulverised material or stabilised mixture shall be assessed for specification compliance on the basis of each 800 m<sup>2</sup> area of the works or part thereof, completed in the same working day.

**34** (05/18) The moisture content specified in sub-Clause 20 of this Clause shall be monitored using test specimens extracted from three bulk samples of pulverised aggregate taken from points evenly spaced along a diagonal bisecting the assessment area. The bulk samples shall comprise material taken from the full depth of the pulverised layer. The depth of pulverisation relative to the designed road level shall be measured and recorded at each point. The samples shall also be tested to determine the particle (or “lump”) size distribution in accordance with BS EN 933-1 (or by an amended method to obtain an early assessment of grading, provided correlation with the standard test method can be demonstrated). Where appropriate, the residue of the three samples shall be combined to form one bulk sample and the bitumen content of the pulverised aggregate determined in accordance with BS EN 12697-1. If any adjustment of moisture content is carried out prior to stabilisation, subsequent samples shall be taken and further moisture content tests completed.

**35** (05/18) The rate of spread of cement, filler, hydrated lime or quicklime shall be measured by weighing the amount of material retained on each of five trays or mats of known area laid in the path of the spreading machine. The trays shall be positioned approximately at points equally spaced along a diagonal bisecting the area of coverage. The mean rate of spread and percentage addition of the material shall be determined and recorded for each assessment area.

**36** (05/18) The rate of supply of bitumen binder and any other fluids to the stabilising plant shall be set and continuously monitored using the appropriate flow rate meters on the stabilising plant. As a check at the start of each work period, the rate of supply of bitumen shall be determined from before and after dip measurements of the storage/delivery tanks, related to an area of stabilisation of not more than 250 m<sup>2</sup>. The calculated supply rate of bitumen for each test area shall be recorded.

**37** (05/18) As directed by the Overseeing Organisation, where lime has been used to modify a cohesive soil component of the pulverised aggregate, the acceptability of the modified materials shall be tested in accordance with sub-Clause 615.9.

- 38** (05/18) After stabilisation, prior to final compaction of the stabilised mixture, five samples of the stabilised material shall be obtained. Each sample shall be taken from a point equally spaced along a diagonal bisecting the area under consideration. The location of each sampling point shall be recorded. Each sample shall comprise at least 40 kg of material taken from the full depth of the layer. The depth of stabilisation relative to the designed road level shall be measured and recorded at each point. Where appropriate and as directed by the Overseeing Organisation, the depth measurements shall be made using a stringline stretched between points of known level.
- 39** (05/18) In the field, each sample of the stabilised material shall be mixed in a tray and sufficient representative material taken to produce a 150 mm cube specimen, made in accordance with the relevant Clauses of Series 800. The refusal density for each cube sample shall be determined to the nearest 10 kg/m<sup>3</sup>. The remainder of each sample shall be retained in a sealed condition for subsequent testing on site or in the laboratory, as described in sub-Clauses 42, 43 and 46 of this Clause.
- 40** (05/18) After trimming and final compaction of the stabilised layer, the in-situ bulk density shall be measured at 50 m intervals per lane, including points close to the material sampling points, using an indirect density gauge in direct transmission mode, to a depth within 25 mm of the total layer thickness. The meter readings shall be verified periodically in accordance with BS EN 13286-2.
- 41** (05/18) The in-situ bulk density values obtained shall be compared with the refusal density value obtained from the cube specimens at the respective sampling points. The average in-situ bulk density of each set of five values shall be at least 95% of the cube refusal density, with no individual in-situ density value less than 93% of the respective refusal density.
- 42** (05/18) Either on site or immediately on arrival at the laboratory, each of the five samples shall be tested for moisture content in accordance with BS 1377-2.
- 43** (05/18) Either on site or within 24 hours of arrival at the laboratory, one 150 mm diameter by 75 mm to 100 mm high cylinder test specimen (briquette specimen) shall be manufactured from each of the five samples, compacted in a PRD mould to a target density of the average in-situ bulk density measured in the field. The final density of each briquette specimen shall be measured and using the respective moisture content values, the dry density values shall be determined.
- 44** (05/18) The curing history of the five briquette specimens prior to testing shall be recorded, which shall, as soon as possible after manufacture, include a period of 72 hours at a nominal temperature of 60°C. Immediately before testing, each briquette specimen shall be conditioned in air for a minimum period of 12 hours at 20°C and then tested in accordance with BS EN 12697-26 (ITSM method) to determine the Indirect Tensile Stiffness Modulus (ITSM) of the material. After removal from the test apparatus, each briquette shall be immersed in water at 20°C for a minimum period of 24 hours, then re-tested to determine the ITSM of the material in a saturated state.
- 45** (05/18) The air voids content of each briquette shall be determined in accordance with BS 598-104 except that the maximum density for the partially coated product, used in the air voids content calculation, shall be standardised using the maximum density determined for a fully coated laboratory prepared specimen. A sample of loose pulverised aggregate obtained prior to the addition of foamed bitumen shall be dried to constant mass at 50°C. Sufficient hot penetration grade bitumen shall then be added in increments to the dried aggregate in a mechanical mixer until the mixture is visually fully coated (using of the order 4% of added bitumen). The coated specimen shall be tested to determine maximum density as specified in BS EN 12697-5.
- 46** (05/18) The residue of the five samples of stabilised material shall be combined to form one bulk sample. From this bulk sample, four sub-samples shall be obtained. Three sub-samples shall be tested to determine the particle size distribution and one sub-sample to determine bitumen content in accordance with BS EN 12697-1. The added bitumen content shall be the measured bitumen content of the stabilised mixture, less the bitumen content of the pulverised aggregate prior to stabilisation.
- 47** (05/18) The specification compliance criteria for the process control tests shall be as described in Table 9/20.

(05/18) **End Product Performance of In Situ Cold Recycled Bitumen Bound Material**

**48** (05/18) The end-product performance of the in situ cold recycled bitumen bound material shall be assessed on the basis of measurements carried out in areas of 800 m<sup>2</sup> or part thereof completed each working day which match the areas defined in sub-Clause 33 of this Clause.

**49** (05/18) Within 24 hours of completion, the as-installed performance of the stabilised layer shall be evaluated using a dynamic plate loading or penetrometer technique to determine values of elastic modulus at points on a nominal grid pattern as described in contract specific Appendix 7/18. The elastic modulus at each point and the mean elastic modulus for the assessment area shall comply with the minimum standards stated in contract specific Appendix 7/18. Additionally, before proceeding with construction of the overlying pavement, the valuation process shall be repeated to demonstrate that the elastic modulus value at all points and that of the mean value have increased over the respective as-installed values by not less than the percentage values stated in contract specific Appendix 7/18. Where these criteria are not met, the full extent of the non-compliant material shall be determined and appropriate remedial measures implemented. Remedial action shall comprise either a delay in construction to allow further curing and stiffening of the layer to occur or a repeat of all or part of the recycling process, followed by re-evaluation, until a compliant material is achieved.

**50** (05/18) Within 270 days of completion of the surfacing works, a Falling Weight Deflectometer survey shall be carried out and analysed in general accordance with HD 29 (DMRB 7.3.2). In particular, the measurements shall be taken on the finished road surface in the nearside wheel path, at a uniform and maximum spacing of 10 m. The survey shall be carried out during a period when the pavement temperature at a depth of 50 mm is within the range 15 to 25°C. The FWD results shall be analysed using a linear elastic FWD back analysis computer program, with the pavement modelled as a two layer system. Layer 1 shall represent the combined design thickness of the bound materials (i.e. the combined recycled material and overlying surfacing materials) and layer 2 shall represent the unbound foundation layer of infinite depth. End product performance shall be defined in terms of the calculated stiffness of layer 1, uncorrected for temperature. Compliance shall be achieved when the rolling mean of 10 results is not less than the figure specified in contract specific Appendix 7/18 and no individual result is less than 85% of the figure specified.

**51** (05/18) In the event that the layer 1 stiffness requirement of sub-Clause 50 of this Clause are not met, the full extent of the non-compliant material shall be determined by further investigation involving coring and laboratory testing. For each area of non-compliance, cores shall be extracted through the full depth of the stabilised layer at locations directed by the Overseeing Organisation, at a minimum rate of one x 150 mm diameter core per 75 m<sup>2</sup>.

**TABLE 9/20: (05/18) Compliance Criteria for Process Control Tests on In Situ Cold Recycled Bound Material**

Material property or characteristic	Individual results	Mean from test set
Relative in-situ density	93% Minimum	95% Minimum
Aggregate grading	In accordance with sub-Clause 3 of this Clause	
Added bitumen content	Target <sup>1</sup> = 0.6%	N/A
Moisture content	Optimum ± 3%	Optimum ± 2%
Layer thickness (site measurement)	± 25 mm of specified	± 15 mm of specified
Cement content (site rate of spread measurement)	Target ± 2%	Target ± 1%
Indirect Tensile Stiffness Modulus (ITSM) – dry specimens	2000 MPa minimum	2500 MPa minimum
ITSM – water saturated specimens	1500 MPa minimum	2000 MPa minimum
Percentage air voids content	12% maximum	9% maximum

Note: subject to the absolute minimum added bitumen content has stated contract specific Appendix 7/18.

**52** (05/18) The Contractor shall be responsible for extraction of the cores with the minimum of force or disruption. Air flush coring shall be allowed for materials that are disturbed by water flush coring. After extraction, each core shall be labelled and photographed and, prior to testing, shall be stored in sealed polythene bags, in a uniformly supported position, at a temperature of 20°C ± 5°C. The thickness of recycled layer shall be measured and recorded.

**53** (05/18) Reinstatement of all core holes shall be completed before opening the area to traffic.

**54** (05/18) If, at any of the prescribed core locations, it is not possible to extract an intact core of suitable size or condition for the end-product performance testing, using a maximum of three attempts in an area of 1.5 m radius, the material in the vicinity shall be deemed not to comply with the end-product performance specification.

**55** (05/18) In the laboratory, each of the cores extracted successfully shall be trimmed to remove surfacing materials and any underlying material prior to cutting into core test specimens between 75 mm and 100 mm high. Where possible, three test specimens shall be obtained from each core, one from the upper part, one from the centre and the other from the lower part.

**56** (05/18) All core test specimens thus obtained shall be tested in accordance with the standards described in Table 9/21.

**TABLE 9/21:** (05/18) **Testing Standards for Core Specimens of In Situ Cold Recycled Bound Material**

Test	Standard
Bulk density	BS EN 12697-6 and sub-Clause 39 of this Clause
Air voids content	BS EN 12697-8 and sub-Clause 45 of this Clause
Indirect Tensile Stiffness Modulus	BS EN 12697-26

**57** (05/18) The results obtained shall be used for assessing the expected performance of the stabilised material in the Works, in relation to the known performance of BS specified base materials. The stabilised material in the trial area shall be deemed acceptable if the compliance criteria described in Table 9/22 are met.

**TABLE 9/22:** (05/18) **Compliance Criteria for In Situ Cold Recycled Bound Material – Core Specimens from the Works**

Material property or characteristic	Individual cores	Mean from core set
Core density relative to refusal density	93% minimum	95% minimum
Air voids content	9% maximum	7% maximum
Layer thickness (from core measurement)	± 25mm of specified	± 15mm of specified
Indirect Tensile Stiffness Modulus – dry	2000 MPa minimum	2500 MPa minimum

(05/18) **Mixture Design and Characterisation**

**58** (05/18) Mixture design and characterisation of in situ cold recycled bitumen bound material for each site, or section of site, including details of filler, binder, adhesion and/or stabilising agent(s) and their quantities, shall be submitted to the Overseeing Organisation at least one week prior to commencement of the recycling works. Where the site investigation has identified significant variation of existing pavement materials between different sections of the site, a mix design shall be submitted for each section of the site. The proposed plan area and depth of the different sections, covered by each mixture design, shall be approved by the Overseeing Organisation.

**59** (05/18) The testing standards used for the mixture design of the recycled bitumen bound mixture shall be those listed in Table 9/23.

**TABLE 9/23: (05/18) Testing Standards for the Design and Characterisation of In Situ Cold Recycled Bound Material**

Test	Standard
Moisture content	BS 1377-2
Bulk density	BS EN 12697-6
Air voids content	BS EN 12697-8 and sub-Clause 45 of this Clause
Grading and Binder Content	BS EN 12697-2
Indirect Tensile Stiffness Modulus	BS EN 12697-26

**60** (05/18) The aggregate used in the design and characterisation process shall be obtained from the appropriate section of the works and shall be representative in terms of component material proportions, of the pavement layers to be pulverised. The laboratory manufactured aggregate shall be pulverised or crushed such that it closely replicates the nature and grading of the pulverised aggregate and that the aggregate particle size distribution shall comply with sub-Clause 3 of this Clause.

**61** (05/18) The laboratory prepared aggregate shall be thoroughly mixed with measured proportions of the bitumen binder and adhesion agent(s) to produce at least three trial mixtures with different added bitumen contents. The penetration reference of the bitumen and the type of the adhesion agent(s) used in the trial mixtures shall be the same as those used in the finished works.

**62** (05/18) The different added bitumen contents of the trial mixtures shall be set at increments of between 0.5% and 1.0% in the range 3.0% to 6.0%, with appropriate allowance made for residual binder in any crushed asphalt component. From each trial mixture, four 150 mm diameter x 75 mm to 100 mm high, cylinder test specimens (briquette specimens) shall be compacted to refusal by vibratory compaction in a cylindrical metal mould, using the compaction mould assembly and vibratory hammer described in BS EN 12697-32. The bulk density of each cylinder shall be determined.

**63** (05/18) The briquette specimens shall be cured for a period of 72 hours at a nominal temperature of 60°C. Following this, the briquette specimens shall be conditioned in air for a minimum period of 12 hours at 20°C and then immediately tested in accordance with BS EN 12697-26 to determine the ITSM. After further conditioning of the briquettes, immersed in water at 20°C for a minimum period of 24 hours, the ITSM tests shall be repeated on each specimen.

**64** (05/18) The characteristics of the mixture to be used in the works, including any added water, shall be determined using the optimum ITSM (dry) values. If peak conditions are not clearly displayed then plateau characteristics shall be accepted and the lowest added bitumen content for which all the criteria defined in Table 9/24 are met, shall be used in the works subject to a minimum of 4.0% for mixtures containing only pulverised unbound or cement bound aggregate and 3.0% for mixtures containing only pulverised bitumen bound materials.

**65** (05/18) On the basis of the foregoing test results, the contractor shall declare details of the Job Standard Mixture(s) for the works, setting out target aggregate grading and type, added water content, adhesion agents and binder content, together with tolerances. The method of compaction shall be described such that the material to be utilised in the works meets the mixture.

**TABLE 9/24: (05/18) Acceptable Design and Characteristic Requirements for In Situ Cold Recycled Bound Material**

Property or characteristic	Individual specimens	Mean from test set
Moisture content	N/A	Optimum $\pm$ 2%
Indirect Tensile Stiffness Modulus (dry)	2000 MPa	2500 MPa
Indirect Tensile Stiffness Modulus (wet)	1500 MPa	2000 MPa
Bitumen content	N/A	Target $\pm$ 0.5%
Particle size distribution	N/A	Zone A or Zone B
Air voids content	9% maximum	7% maximum

## 948 (05/18) Ex Situ Cold Recycled Bound Material

### (05/18) General

**1** (05/18) Ex situ cold recycled bound material (CRBM) comprises base and binder courses produced in a fixed or mobile mixing plant from graded aggregate processed from arisings from the excavation of roads and similar sources, blended if necessary with other aggregate and bound with cementitious, hydraulic or bituminous binders, separately or in combination. This Clause covers four generic material families: Quick Hydraulic (QH), Slow Hydraulic (SH), Quick Visco-Elastic (QVE) and Slow Visco-Elastic (SVE). The primary binder of these families of materials shall be as follows:

**QH:** Cement as the main component and excluding bituminous binders.

**SH:** Hydraulic binders (e.g. PFA/lime and GBS/lime) excluding bituminous and Portland Cement;

**QVE:** Bituminous binder as the main component but also including Portland Cement.

**SVE:** Bituminous binder as main component but excluding Portland Cement.

**2** (05/18) Ex situ CRBM shall be designed to achieve the specified level of the appropriate end performance property

### (05/18) Quality Assurance

**3** (05/18) Ex situ CRBM shall be produced in plants that have a UKAS accredited BS EN ISO 9001 Quality Management System. The BS EN ISO 9001 Certificate scope shall include this activity.

### (05/18) Sourcing of Aggregate

**4** (05/18) The quality plan shall contain details of all aggregates to be used in the CRBM. Aggregate may include:

- (i) asphalt, concrete or granular material planed or excavated from a road or other paved area;
- (ii) primary, secondary or recycled aggregate from other sources;
- (iii) fillers from primary or secondary sources (e.g. PFA).

**5** (05/18) The processed aggregate including added filler shall not contain deleterious material that adversely affects the performance of the mixture.

### (05/18) Processing of Aggregate

**6** (05/18) The quality plan shall describe how, in particular, highway arisings are to be processed, crushed, screened and stocked to enable consistent production of the CRBM in line with the Job Standard mixture.

(05/18) **Binders and Other Constituents**

- 7 (05/18) The bitumen and other constituents shall conform to the following standards:
- (i) Bitumen emulsion shall conform to BS EN 13808 and be used in accordance with BS 434-2.
  - (ii) Cement shall conform to BS EN 197-1.
  - (iii) Bitumen used for foaming shall conform to BS EN 12591 and shall be grade 160/220 or harder.
  - (iv) Granulated blast furnace slag (GBS) shall comply with EN 14227-2.
  - (v) Ground granulated blast furnace slag (GGBS) shall comply with BS EN 14227-2.
  - (vi) Lime shall comply with BS EN 14227-11.
  - (vii) Fly ash (PFA) used as either as filler or pozzolan, shall comply with BS EN 14227-4.
  - (viii) Un-weathered 0/4mm Basic Oxygen Slag (BOS) slag fines used in SH material as activator/accelerator to the GBS shall comply with BS 6463 Part 102.
- 8 (05/18) Subject to approval, other constituents including setting and hardening agents may be used to enhance the performance of the mixture. Water shall not contain material that adversely affects the performance of the mixture.

(05/18) **Job Standard Mixture**

- 9 (05/18) The composition of the job standard mixture shall be declared as follows:
- (i) Source, origin and proportion of all aggregate constituents.
  - (ii) Combined target grading, including mineral binders and tolerances.
  - (iii) Source, origin and proportion of all binders.
  - (iv) Target moisture content.
- 10 (05/18) The grading of the job standard mixture, i.e. the aggregate together with the other constituents including hydraulic binders, shall comply with one of the zones in Table 9/25.
- 11 (05/18) Use of Zone B or C graded material shall be permitted only when the results of a full mix design showing compliance with the required 28 day performance properties are available or when evidence can be provided of satisfactory achievement of the performance requirements on an earlier contract with a similar composition.

**TABLE 9/25: (05/18) Particle Size Distribution of Mixture for Cold Recycling**

Sieve (mm)	Percentage by mass passing		
	Zone A	Zone B	Zone C
40	100	100	100
31,5	100	100	86-100
20	100	100	65-100
14	85-100	85-100	52-100
10	68-100	68-100	44-100
4	38-74	38-94	26-74
2	26-58	26-84	18-58
0,5	13-38	13-64	8-38
0,250	9-28	9-51	5-28
0,063	5-21	5-38	3-21

The binder addition shall comply with Table 9/26.

**TABLE 9/26: (05/18) Minimum Binder Contents for Ex Situ Construction by Family and Binder Type**

Family	OPC	Lime	PFA	GBS	GGBS	Bitumen*
QH	3%	–	–	–	–	–
	2%	–	4%	–	–	–
	2%	–	–	3%	–	–
	2%	–	–	–	2%	–
SH	–	2%	8%	–	–	–
	–	2%	–	6%	–	–
	–	2%	–	–	4%	–
	–	1%	–	10%	–	–
	–	–	–	10%	–	–
QVE	1%	–	**	–	–	3%
SVE	–	1.5%***	**	–	–	3%

\* foamed or emulsion (residual)

\*\* PFA may be added as filler

\*\*\*lime may be added for 'breaking' and adhesion purposes, and, if PFA included as filler, will contribute to strength

**(05/18) Mixture Design Validation**

**12** (05/18) When a mix design validation is required it shall be carried out on aggregates and binders representative of those to be used on the works. The validation may be carried out on CRBM mixed either in the laboratory or on a pilot basis on a full scale plant.

**13** (05/18) The target mixture shall comply with sub-Clauses 5 and 6.

**14** (05/18) A preliminary exercise shall be undertaken to establish a target grading and suitable moisture content.

**15** (05/18) Representative samples of the mixture shall be taken and from these 150 mm diameter cylindrical specimens shall be produced in accordance with sub-Clause 14. These specimens shall be 150 mm high for hydraulic bound mixtures and 70-75 mm high for visco-elastic bound mixtures. The time between mixing and specimen production shall be in accordance with the setting times given in Table 9/29.

**16** (05/18) The density of each specimen shall be measured and using the respective moisture content values, the dry density values shall be determined. The cylindrical specimens shall be conditioned and tested. The conditioning and testing regime shall be agreed with the Overseeing Organisation and the measured characteristics shall demonstrate compliance with the requirements of Table 9/27.

**17** (05/18) The performance properties of the conditioned specimens shall be declared. The results shall be considered as indicative only, as the compliance criteria apply only to the specimens prepared during the execution of the works.

**TABLE 9/27: (05/18) Mix Design and End Product Requirements**

Property or Characteristic All Materials		Mean from Test Set
<b>QVE and SVE Materials (360 days*)</b>		
Indirect Tensile Stiffness Modulus	Class B1	1900 MPa
	Class B2	2500 MPa
	Class B3	3100 MPa
	Class B4	4700 MPa
<b>QH and SH Materials (360 days*)</b>		

\*Note: 360 days in situ or cured in accordance with sub clause 15.

(05/18) **Trafficking Trial**

**18** (05/18) When specified in contract specific Appendix 7/1 a trafficking trial shall be undertaken to demonstrate that the CRBM is not prone to excessive rutting in its early life.

**19** (05/18) A trial area shall be laid using the materials and plant to be used in the main works and on a foundation typical of that in the main works. The trial area shall be left to cure for 24 hours and shall then be subjected to controlled trafficking. The trafficking shall be performed by a heavy goods vehicle with an axle configuration and loading typical of that to be encountered in the construction phase. The number of passes shall equate to the total expected amount of traffic to be carried during construction, with a default value equivalent to 100 standard axles.

**20** (05/18) The measured rutting in the trafficking trial shall be less than 10 mm or that specified in contract specific Appendix 7/1.

(05/18) **Process Control**

**21** (05/18) Production of the ex situ CRBM shall be subject to process control detailed in the quality plan and meeting the following requirements:

- (i) There shall be a description of the plant and the production process, preferably including a flow diagram, detailing how material is to be produced in accordance with this specification.
- (ii) Calibration schedules for all parts of the plant involved in determining mix consistency shall be provided. These shall be accompanied by calibration records.
- (iii) Details of transportation shall be provided. These shall include the location of the mixing plant and the expected average time between mixing and laying. The Contractor shall record the duration between mixing and the completion of compaction at the site during the execution of the works.
- (iv) Measures to avoid problems caused by extreme weather. In particular, production shall not proceed if the feedstock is frozen or excessively wet.

(05/18) **Inspection and Test**

**22** (05/18) There shall be a schedule of inspection and test frequencies to be made during production of CRBM. This shall comply with the minimum frequencies in Table 9/28.

**TABLE 9/28:** (05/18) **Minimum Frequencies for Inspection and Test**

Item	Inspection	Test
Aggregate stockpiles	Daily	Grading and moisture content Before production and weekly
Binders	On receipt	Supplier data
Combined grading of mixture	Continual	Daily
Moisture content of mixture	Continual	Daily

(05/18) **Laying**

**23** (05/18) A written procedure for the laying of the ex situ CRBM shall be provided.

**24** (05/18) The plant used for placing ex situ processed material shall be capable of laying the material without significant segregation, evenly and to the required thickness across at least one lane width.

**25** (05/18) A method for the making of longitudinal and transverse joints, appropriate to the type of CRBM being laid shall be provided.

(05/18) **Compaction**

**26** (05/18) The compaction of each layer shall be carried out to a defined rolling pattern, to achieve the required in situ density and until the recycled layer provides a stable and dense tight surface. The stability of the layer after compaction shall be deemed adequate if the finished surface does not shove, rut or exhibit transverse cracking under the load of subsequent traffic. Open edges shall be protected from traffic.

**27** (05/18) After trimming and final compaction of the recycled layer, the in situ bulk density shall be measured using an indirect density gauge in direct transmission mode, to a depth within 25 mm of the total layer thickness. The meter readings shall be verified periodically in accordance with BS EN 13286-2.

**28** (05/18) The in situ bulk density values obtained shall be compared with the refusal density value of the Job Standard Mix or of the refusal density of a specimen representative of the day's production. The average in situ bulk density of each set of five values shall be at least 95% of the refusal density, with no individual in situ density value being less than 93% of the respective refusal density.

(05/18) **Sealing**

**29** (05/18) When specified in contract specific Appendix 7/1, the surface shall be sealed using a sprayed membrane of Class C40B4 bitumen emulsion complying with Clause 920. The bitumen emulsion shall be sprayed at a rate 1 to 1.5 l/m<sup>2</sup> to achieve a uniform and continuous seal to the surface of the layer. Where the surface is opened to traffic, the sealing membrane shall be blinded with fine aggregate or sand applied at a rate of 5.5 to 7.0 kg/m<sup>2</sup>.

(05/18) **End Product Testing**

**30** (05/18) The end product testing of the ex situ CRBM shall be assessed on the basis of representative specimens made up in accordance with the schedule in contract specific Appendix 7/1.

**31** (05/18) Representative samples of the ex situ CRBM shall be taken either at the mixing plant or from site. 150 mm diameter cylindrical test specimens shall be manufactured in sets of six by compacting to refusal in accordance with BS 598 Part 104. The height of the test specimens and the time period after mixing during which compaction must be completed shall be in accordance with Table 9/29.

**TABLE 9/29: (05/18) Setting Times of Cold Recycled Families**

Family	Setting time under normal temperature conditions	Sample dimensions prepared to a target density	
		Diameter (mm)	Height (mm)
QH	2 hours	150	150
SH	24 hours*	150	150
QVE	2 hours	150	75
SVE	24 hours*	150	75

\* can be longer depending on material composition

**(05/18) Conditioning and Testing of Samples**

**32** (05/18) Prior to testing, specimens shall be conditioned in a controlled environment, sealed to keep the moisture in, as described in this clause. The purpose of this conditioning is to simulate the likely curing over the first year in the road.

**33** (05/18) Immediately after compaction, the cylindrical specimens, in their moulds shall be double wrapped in cling-film plastic using two separate sheets; each of which shall be sufficient to cover the entire circumference of the cylinder and the two ends of the specimen. Once wrapped in cling-film the sample shall be placed in a sealed plastic bag. Care shall be taken when handling the specimens not to damage the plastic bag or the underlying cling-film layer. The specimens should be stored in air or water at a temperature within 2°C of the nominal conditioning temperature.

**34** (05/18) The following conditioning regimes shall apply:

- (i) QH specimens shall be conditioned for a period of 28 days at a temperature of 20+2°C.
- (ii) SH and QVE specimens shall be conditioned for a period of 28 days at a temperature of 40+2°C.

**(05/18) End Product Criteria**

**35** (05/18) The minimum specification compliance criteria for the process control tests shall be as described in Table 9/30.

**TABLE 9/30: (05/18) End Product Criteria**

Material property or characteristic	Individual results	Mean from test set of six specimens
Particle Size Distribution	Zone	–
Moisture content	±2%	–
Relative In situ density	93% minimum	95% minimum
Layer thickness	±25 mm of specified	±15mm of specified
Indirect Tensile Stiffness Modulus or Indirect Tensile Test	N/A	Relevant value from Table 9/27 less 5%

In the event of test specimens failing to achieve the required indirect tensile test results, compliance shall be determined by the testing of cores extracted by dry coring after one year. The results shall be compared with the criteria in Table 9/27.

**949 (05/18) Not Used**

**950 (05/18) Surface Preservation Systems**

1 (05/18) Systems that are intended to extend the life of existing asphalt surfacing by the application of a proprietary liquid coating shall have HAPAS or equivalent product acceptance scheme certification to demonstrate their performance. Preservation systems without HAPAS or equivalent certification shall not be used without prior approval by the Overseeing Organisation.

**951 (05/18) Torque Bond Test**

- 1 (05/18) The bond strength between a thin surfacing system and its substrate, which may be bituminous or cementitious, shall be established between 28 and 56 days after the SIPT is installed by measuring the peak shearing torque at a known temperature.
- 2 (05/18) Six evenly spaced, 100±5 mm diameter cores shall be cut to a depth of 20 mm below the thin surfacing layer to be tested, along a diagonal line across the lane width from a 100 m length of the installation. The surface to be tested must be clean and dry.
- 3 (05/18) A metal plate of mild steel having a diameter of 95±5 mm and a thickness of 14±2 mm, incorporating a fitting to enable it to be coupled to a torque meter shall be secured to the surface of the core using a suitable bonding agent, taking care to ensure that the plate is parallel to the surface.
- 4 (05/18) When the bonding agent has developed sufficient strength, (ie. failure should not occur within the adhesive) a torque meter, fitted with a fiducial reading gauge, calibrated over a range of 0-350 Nm with a scale readable to at least 10 Nm, shall be fitted to the metal plate, using adapters and extension rods as appropriate.
- 5 (05/18) Torque shall be applied to the core at a steady rate so that the torque wrench sweeps an angle of 90° within 30±15 seconds. Care must be taken to ensure that the torque is applied parallel to the core surface within ± 10°. Torque is applied to the plate until failure of the bond occurs or a torque of 300 Nm is exceeded.
- 6 (05/18) The value of torque at failure shall be recorded in Newton metres (M). The bond interface temperature shall be measured and recorded immediately after failure, using a thermometer readable to a temperature of 0.1°C and accurate to 0.5°C.
- 7 (05/18) The core diameter shall be measured and recorded at two locations approximately 90° apart using callipers and the mean value, D, recorded to an accuracy of 1 mm.
- 8 (05/18) The bond strength is calculated for each specimen using the following formula:

$$\tau = \frac{12M \times 10^6}{\pi D^3}$$

where:

- $\tau$  : inter-layer bond strength in kiloPascals (kPa),  
M : peak value of applied shearing torque in Newton metres (Nm),  
D : diameter of core in millimetres (mm)
- 9 (05/18) The arithmetic mean of the inter-layer bond strength,  $\tau$ , for the six specimens shall be calculated and shall be greater than or equal to 400 kPa.

**10** (05/18) The test report shall include the name of organisation carrying out the test, description of materials (system and substrate), date of test, peak torque at failure (Nm), inter-layer bond strength (kPa), (individual and mean values), time to failure (seconds), diameter of core (mm), depth of Bond interface (mm), temperature of the bond interface at test (°C), identification of site or scheme, core location, age of the installation/specimen at the time of test, nature of the bond interface, mode of failure.

**952 & 953** (05/18) **Not used**

### **954** (05/18) **Method for Laboratory Determination of Interface Properties Using the Modified Leutner Shear Test**

(05/18) **Scope**

**1** (05/18) This Clause specifies a laboratory test method to assess the bonding between adjacent asphalt pavement layers using cylindrical samples. It is also appropriate for asphalt applied to concrete.

(05/18) **Terms and Definitions**

**2** (05/18) For the purposes of this Clause the terms and definitions given in BS 6100 shall apply, together with the following:

- (i) **Peak Shear Stress:** The maximum value of shear stress, determined as the maximum force divided by the initial cross sectional area of a specimen when tested as described in this Clause.
- (ii) **Displacement at Peak Shear Stress:** The displacement at the maximum value of shear stress of a specimen when tested as described in this Clause.
- (iii) **Shear Stiffness Modulus:** The peak shear stress divided by the displacement at the peak shear stress of a specimen when tested as described in this Clause.

(05/18) **Principle of Test**

**3** (05/18) Cylindrical test specimens of nominal 150 mm diameter shall be subjected to direct shear loading at 20°C using the modified Leutner shear test. The maximum shear stress (in MPa) at the interface between layers shall be determined.

(05/18) **Test Apparatus and Materials**

**4** (05/18) The following test apparatus and materials shall be used:

- (i) Shear test apparatus, as shown in Figure 9/2, composed of a base body (A) on which are fixed the sample support (B) and the lower shear ring (D). The upper shear ring (C) is attached to the upper body (E), which is movable along the guiding bars (F). The gap between shear rings (C and D) is 5 mm.
- (ii) Loading frame capable of achieving a constant vertical displacement rate of  $50.0 \pm 2$  mm per minute and a maximum load of at least 50kN.
- (iii) Data logging system to record load and displacement during the test.
- (iv) Metal extension, as shown in Figure 9/3.
- (v) Stiff adhesive, such as epoxy resin, with sufficient strength to avoid failure within the adhesive or at the adhesive/asphalt material interface.

(05/18) **Sample Preparation**

5 (05/18) Test specimens shall be cores of  $150 \pm 2$  mm diameter; the minimum thickness of the layers above and below the interface to be tested shall be 15 mm and 60 mm respectively. Specimens shall be cored from an in-service pavement or from a slab manufactured using a laboratory roller compactor in accordance with BS EN 12697-35 and BS EN 12697-33. If the thickness of the layer above the interface is between 15 and 30 mm, a metal extension shall be glued on top of the layer above the interface.

(05/18) **Procedure**

6 (05/18) The diameter and thickness of the specimen shall be determined to the nearest mm.

7 (05/18) The specimen shall be placed into a suitable temperature controlled conditioning environment at  $20 \pm 0.5^\circ\text{C}$  for a minimum of 5 hours.

8 (05/18) The appropriate shear rings, to form a loose fit around the specimen (for example, 151 mm diameter shear rings for a 150 mm diameter specimen), shall be selected and attached to the Leutner test frame.

9 (05/18) The specimen shall be placed into the test apparatus and the interface aligned, (Figure 9/2 (G)), between the upper and lower shear rings (Figure 9/2 (C and D)). If a metal extension is used, the specimen shall be placed into the test apparatus so that the direction of the grooves is perpendicular to the direction of the applied shear load.

10 (05/18) Tighten the sample support using a suitable spanner.

11 (05/18) The test apparatus shall be placed into the loading frame and adjusted until the upper shear ring (Figure 9/2 (C)) nearly touches the specimen.

12 (05/18) Start the data logging system (to record load and displacement) and commence shear loading. The loading rate shall be  $50.0 \pm 2$  mm per minute.

13 (05/18) Record the load ( $F$ ) to the nearest 0.1 kN and the displacement ( $\delta$ ) to the nearest 0.1 mm.

14 (05/18) Stop the shear loading when the test frame reaches its limit of 7 mm displacement. The length of time between removal of the specimen from the temperature controlled conditioning environment and completion of testing shall not exceed 15 minutes.

15 (05/18) After the test has been completed, the apparatus shall be dismantled and the specimen removed.

16 (05/18) Both sections of the specimen shall be observed (especially the interface) for any visual cracks and unusual appearance (i.e. crushed aggregates on edges). Record any comments as necessary.

(05/18) **Calculation and Expression of Results**

17 (05/18) Calculate the shear stress as follows:

$$\tau = \frac{F}{\pi r^2}$$

Where:

$\tau$  = shear stress in (MPa)

$F$  = load (in kN)

$r$  = initial radius of specimen (in mm)

18 (05/18) Produce a shear stress versus shear displacement graph (an example is shown in Figure 9/4) using the recorded data.

19 (05/18) Determine the following parameters from the graph:

- (i)  $\tau_{\max}$  = peak shear stress, MPa, expressed to the nearest 0.1
- (ii)  $\delta_{\max}$  = displacement at peak shear stress, mm, expressed to the nearest 0.1
- (iii)  $k$  = shear stiffness modulus =  $\tau_{\max} / \delta_{\max}$ , MPa/mm, expressed to the nearest 0.1

(05/18) **Test Report**

20 (05/18) The test report shall contain not less than the following information:

- (i) A reference to this test method and test conditions.
- (ii) Material descriptions for both layers.
- (iii) Type and amount of tack (bond) coat (if known).
- (iv) For each specimen tested, report:
  - specimen diameter, expressed to the nearest mm
  - layer thicknesses, expressed to the nearest mm
  - maximum load ( $F$ ), expressed to the nearest 0.1 kN
  - peak shear stress ( $\tau_{\max}$ ), expressed to the nearest 0.1 MPa
  - displacement at peak shear stress ( $\delta_{\max}$ ), expressed to the nearest 0.1 mm
  - shear stiffness modulus ( $k$ ), expressed to the nearest 0.1 MPa/mm
  - any cracks or other damage.
- (v) The test temperature, expressed to the nearest 0.5°C
- (vi) The use (or otherwise) of a metal extension.

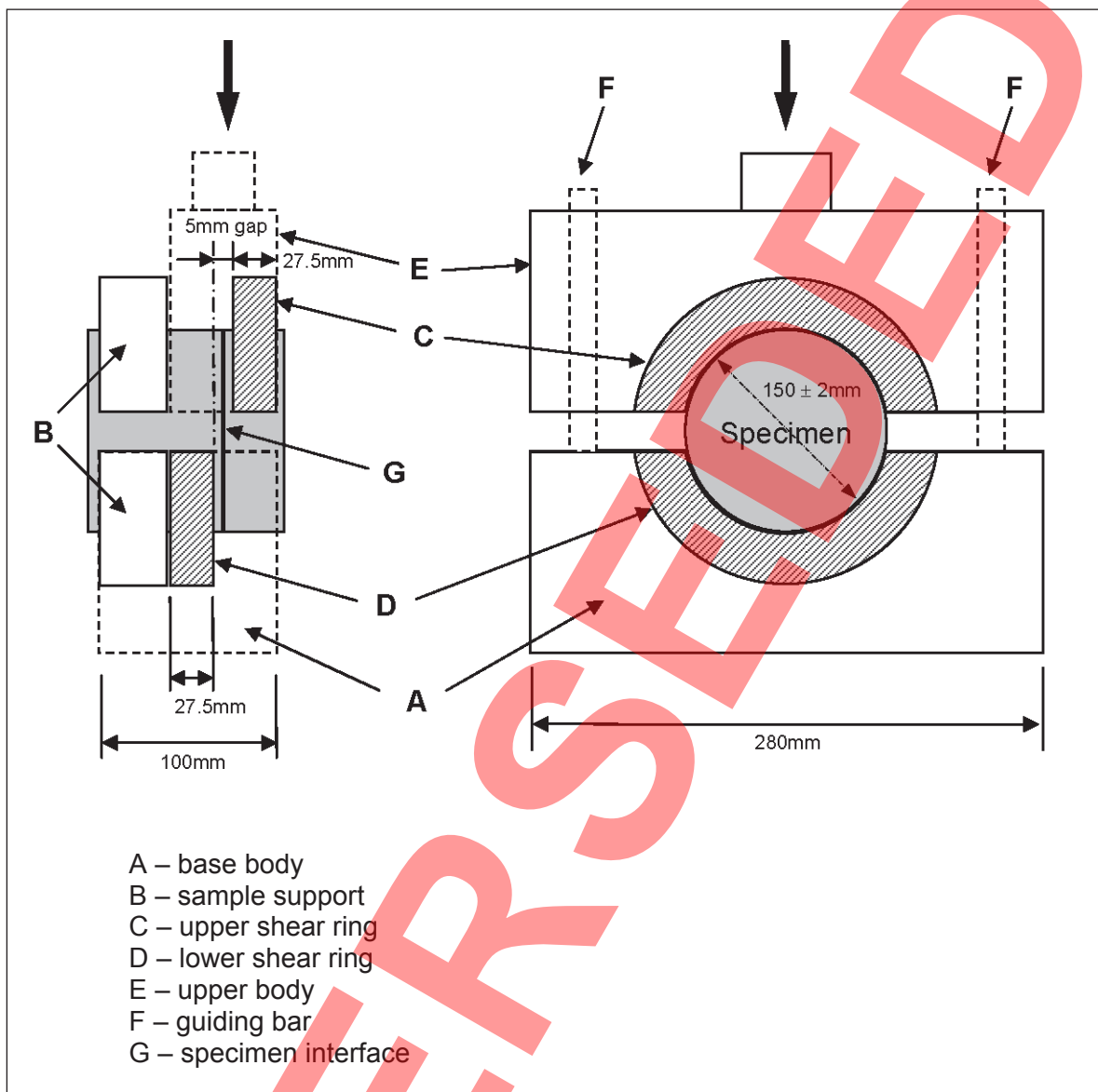

FIGURE 9/2: (05/18) Schematic Diagram of the Modified Leutner Shear Test apparatus

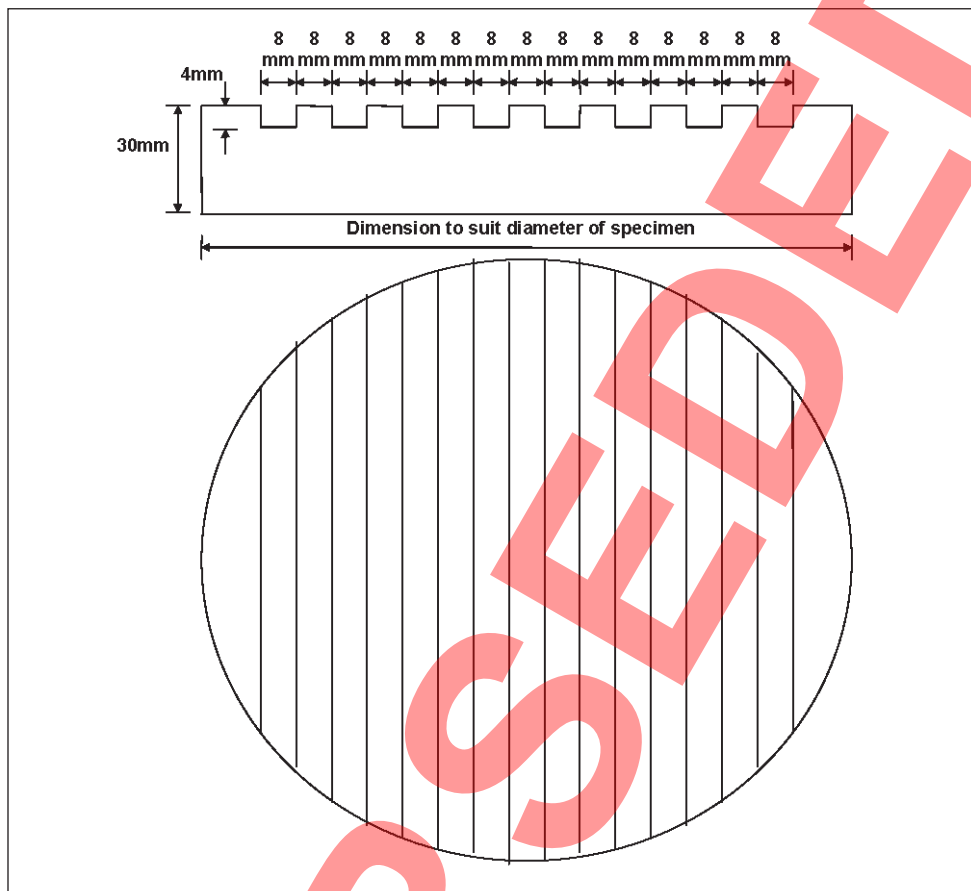

FIGURE 9/3: (05/18) Schematic Drawing of the Metal Extension

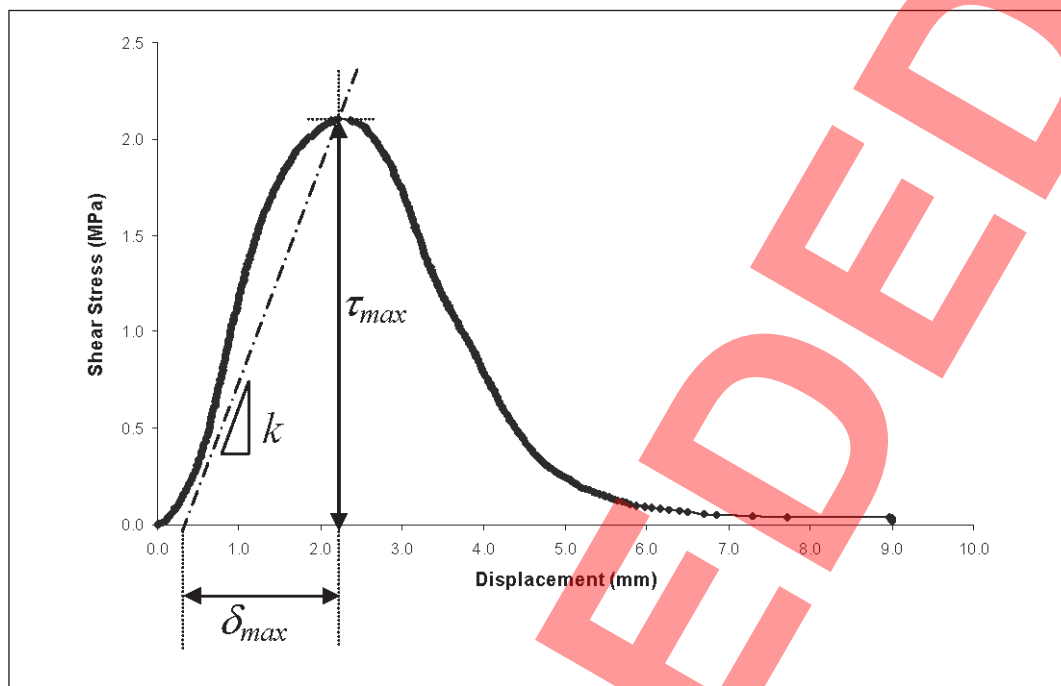

FIGURE 9/4: (05/18) Example of Shear Stress vs Displacement Data Plot

### 955 (05/18) Ageing Profile Test Using a Modified Rolling Thin Film Oven Test (MRTFOT)

#### (05/18) Scope

1 (05/18) This Clause specifies the procedure for obtaining samples of ‘Aged Binder’ after various stages of conditioning. In this way, a plot of binder properties providing an ‘Ageing Profile’ may be accomplished in a short time using the Modified Rolling Thin Film Oven Test (MRTFOT) to simulate ageing in road materials over many years in service.

The MRTFOT utilises the Rolling Thin Film Oven (ASTM 2872) specified in BS EN 12607-1.

The method is suitable for generating small quantities of binder for rheological testing

The ‘Ageing Profile’ is generated by determining the rheological properties of complex shear (stiffness) modulus  $G^*$  and phase angle  $\delta$  of samples taken from the oven at intervals throughout the test period, typically one day. Other properties such as durability of cohesion may also be assessed.

Three protocols are used depending on the type of binder and its use:

- (i) a method to simulate ageing of polymer modified binder or paving grade bitumen used in the manufacture of asphalt;
- (ii) a method to remove the water phase and volatile flux from polymer modified bituminous emulsions and simulate ageing and;
- (iii) a method to test the potential for preservatives to reduce the ageing rate of bitumen.

The ‘Ageing Profile’ in terms of rheological characteristics provides ‘Product Identification’ and this is essential to ensure consistency and to enable proprietary binders to be identified.

(05/18) **Warning**

2 (05/18) The use of this test method can involve hazardous materials, operations and equipment. This Clause does not purport to address all of the safety problems associated with the use of the test method. It is the responsibility of the user of these test methods to establish appropriate safety and health practices and determine the applicability of regulatory limitations prior to use.

(05/18) **Asphalt Binders**

3 (05/18) Binders used to manufacture hot mixed asphalt (asphalt binders) are first subjected to a 'Short-term Ageing Test' to simulate the effects of manufacture, transport and laying. In this respect, the test described in this Clause has been shown to be equivalent to BS EN 12607-1. The binder is continually stirred by rotating stainless steel screws in sample cans to obtain a homogeneous sample; the procedure also benefits from a faster oxidation rate (rapid ageing), because of the increased exposure to the jetted air stream and, therefore, a shorter test duration.

The binder samples are then aged at a lower temperature and samples removed at intervals and tested to obtain an 'Ageing Profile'. This is particularly useful for asphalt, because different air void contents and binder contents in a road pavement result in different ageing rates.

The 'Long-term Aged' binder sample, where the characteristics are equivalent to those obtained after 65 hours using the Pressure Ageing Vessel PAV85 Test, is obtained after 7 hours; therefore, the test may be carried out in one day. PAV85 is detailed in BS EN 14769.

Binders used for manufacturing 'Warm Asphalt' are mixed at much lower temperatures than for hot mixed asphalt and they do not need the same high temperature protocol for 'Short-term Ageing'; this part of the procedure is therefore amended for these binders. All the ageing is done at the lower temperature.

(05/18) **Bituminous Emulsion Binders**

4 (05/18) Bitumen and polymer modified bituminous emulsions are first subjected to a 'Rapid Recovery Test' which removes any water phase and volatile oils to produce a 'Recovered Binder'. The 'Recovered Binder' has similar properties to that produced from other evaporative tests, but is achieved over a shorter period and the use of nitrogen, replacing air, reduces risks associated with volatile oils in the oven. The 'Recovered Binder' in rheological terms is equivalent to that recovered using BS EN 13074-1.

The 'Ageing Profile' is provided by continuing the ageing of the 'Recovered Binder' in the MRTFO at a higher temperature, replacing the nitrogen gas with air and removing samples after specified periods for testing. A 'Stabilised Binder', equivalent in rheological terms to that produced using BS EN 13074-2, may be obtained from the 'Ageing Profile' Plot for a particular emulsion. Fluxed and vegetal fluxed binders where volatile oils are thought to be present may also be tested using this protocol.

(05/18) **Preservatives**

5 (05/18) 40/60 penetration grade bitumen, used as a control, is subjected to 'Short-term Ageing' in the MRTFOT followed by an extended period at a lower temperature to simulate the ageing of the bitumen in a road pavement. This aged bitumen control is then cooled to ambient and treated with the preservative. Most of the volatile oils are then removed by conditioning the samples in the MRTFOT using a nitrogen blanket. The aged bitumen, treated by preservative, is then subjected to further ageing with the MRTFOT. The properties of the aged bitumen, after action of the preservative, are assessed by an 'Ageing Profile' using rheology and compared with the 'Ageing Profile' of the control bitumen.

(05/18) **Definitions**

6 (05/18) For the purposes of the procedures specified in this Clause the following definitions apply:

- (i) **Laboratory Sample:** sample of bituminous binder intended for laboratory tests. It may be a spot sample, a composite sample or a part thereof (a divided sample) as described in BS EN 58.
- (ii) **Test Sample:** sample of bituminous binder produced by treatment or subdivision of a laboratory sample for individual test (BS EN 58).

- (iii) **Recovered Binder:** material remaining after removal of water or flux from a polymer modified or unmodified bituminous emulsion or fluxed binder in the presence of nitrogen, equivalent to the recovered binder using BS EN 13074-1.
- (iv) **Aged Binder:** material remaining after the Ageing protocol.
- (v) **Short-term Aged Binder:** material obtained during the MRTFOT which is equivalent to that provided by BS EN 12607-1(RTFOT)
- (vi) **Long-term Aged Binder:** material obtained during the MRTFOT which is equivalent to that provided by BS EN 14769
- (vii) **Ageing Profile:** graphical plot of performance-related results from samples tested during the ageing protocol of this method. Performance-related testing is carried out using a Dynamic Shear Rheometer (DSR), providing  $G^*$  and phase angle data at a determined temperature and frequency.

(05/18) **Test Apparatus (common to all protocols)**

7 (05/18) The following test apparatus shall be used:

- (i) RTFOT apparatus to BS EN 12607-1.
- (ii) Eight identifiable sample cans with threaded screw top lids (or other fixing system) manufactured from aluminium and coated on all internal surfaces with polytetrafluoroethylene (PTFE) with internal dimensions and aperture diameter (L2) as shown below:

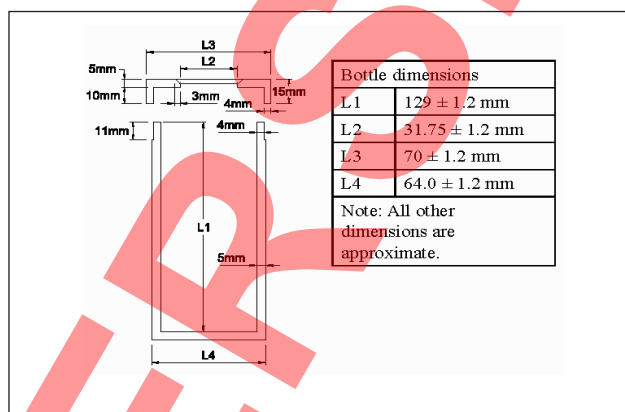

The taper in the throat (from L2 aperture to lid top) is  $45 \pm 5^\circ$



**FIGURE 9/5: (05/18) Sample Can and Lid (both with threads)**

- (iii) Eight screws manufactured from high quality stainless steel (surgical quality) complying with BS EN 10088-3, designation 1.4404 to a 'fine machined finish'. All screws shall have dimensions: diameter  $12.2 \pm 0.2$ mm, length  $120 \pm 0.5$ mm and have between 18 and 19 turns with a pitch of  $6 \pm 0.2$ mm. The depth of cut shall be  $2 \pm 0.2$ mm with a semi-circular profile – see Figure 9/6. At one end, the screw shall have an unthreaded shank  $10 \pm 0.5$ mm long and  $7.5 \pm 0.5$ mm diameter, ending in a  $45^\circ$  cone, truncated to give a flat end at the apex  $1.5$  to  $2.0$ mm diameter. The minimum weight of a screw shall be 70g. The direction of screw shall be such that the binder sample is drawn to the closed end of the sample can bottle when the can containing the screw is rotated in the carousel. If the RTFO carousel rotates anticlockwise, viewed from the front, screws with a right-hand thread are required and if the carousel rotates clockwise, screws with a left hand thread are required.

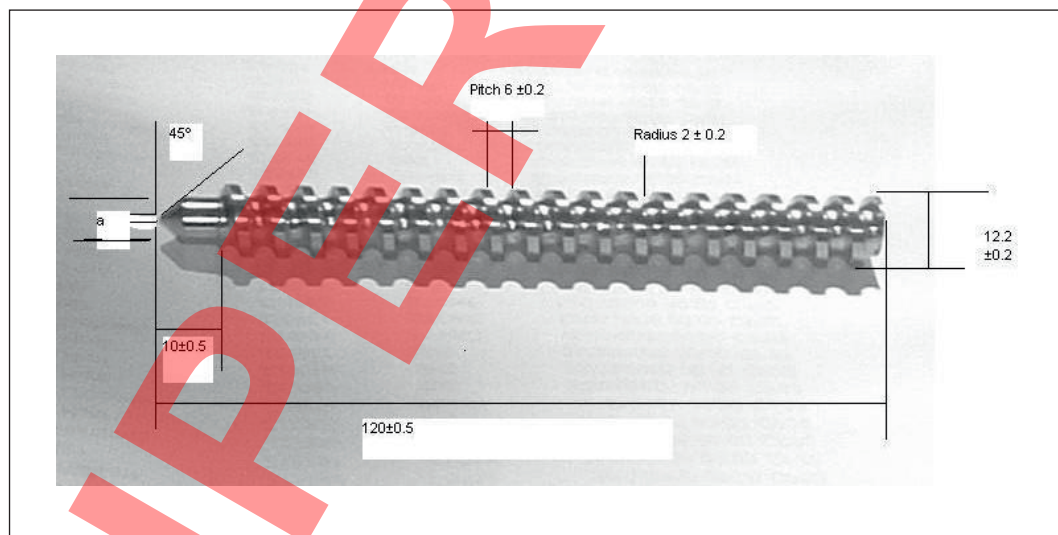

Dimension a = 1.5mm to 2mm

**FIGURE 9/6 (05/18) Screw with Right-handed Thread (for anti-clockwise rotating carousel)**

- (iv) A spatula for removing the binder from the sample cans (a flat blade with a square end has been found suitable).
- (v) A balance accurate to 0.05g.

- (vi) A timer capable of timing 100 minutes, accurate to 1 second in five minutes and, for the MRTFOT, a timer capable of timing 25 hours to the same accuracy.
- (vii) Nitrogen gas supply (for Rapid Recovery Test and preservative test).
- (viii) Air supply, clean dry air (for MRTFOT).
- (ix) An oven to pre-heat the sample cans and the binder to the required temperature.

**(05/18) Principle of the Ageing Profile Test for Polymer Modified and Unmodified Bituminous Binders for Asphalts**

**8** (05/18) A thin film of binder is rotated in aluminium sample cans with screw top lids, both coated internally with PTFE (replacing glass bottles), using the Rolling Thin Film Oven Test (RTFOT) apparatus, as described in BS EN 12607-1. Special screws are used to disturb the binder and maintain a homogenous material during 'Ageing'. Air is jetted over the film of binder for a much longer period than in the conventional test and a lower temperature used in order to simulate the 'ageing' of the binder in the road after application. The screws accelerate the process, and are necessary to maintain a homogeneous sample, especially when testing polymer modified binders, which tend to form a skin and may phase separate in static ageing tests.

The initial conditioning test is to simulate the changes to the properties of the binder caused by the high temperatures during manufacture, transport and laying, termed 'Short-term Ageing'.

Further ageing is carried out at a reduced temperature and samples removed after set periods and tested, so that an 'Ageing Profile' may be plotted.

**(05/18) Test Procedure for Determining the Ageing Profile of Hot Mixed Polymer Modified and Unmodified Bituminous Binders for Asphalts**

**9** (05/18) Obtain a sample in accordance with BS EN 58. Stir the sample thoroughly to ensure it is completely homogenized. If sub-samples are taken these shall have a minimum volume of 250ml. Ensure that the RTFO is level so that the horizontal axes of the sample cans when in position in the carousel are level. Pre-heat the oven to  $163 \pm 1^\circ\text{C}$ , 1h is generally sufficient. For binders used to manufacture warm mixed asphalts, substitute  $135^\circ\text{C}$  for  $163^\circ\text{C}$  throughout the test procedure.

Insert a stainless steel screw into each of the sample cans with the tapered end of the screw towards the aperture of the container and record the mass of each assembly to 0.1g. Heat the sample cans and the stainless steel screws to  $163 \pm 1^\circ\text{C}$  for  $90 \pm 10$  min.

Heat the sample to  $170 \pm 3^\circ\text{C}$ . Thoroughly stir the sample to ensure homogeneity immediately prior to decanting into the sample cans.

Pour  $19.0 \pm 0.5\text{g}$  of the sample into a preheated sample can and record the mass with lid. Immediately after weighing, roll the sample cans to ensure distribution of the binder on the walls of the can.

Mount the sample can in the carousel of the RTFO. Repeat for the remaining sample cans. Close the door of the RTFO between mounting each sample can in the carousel. The period between weighing the first sample can with binder and mounting of all the sample cans and the start of the rotation of the carousel shall not exceed 20 minutes.

When the carousel is fully loaded, rotate the carriage assembly at a speed of  $15.0 \pm 0.2\text{min}^{-1}$ . Start the flow of air at a set rate of  $4000 \pm 200\text{ml/min}$ . Start the timer. Maintain the samples in the oven and the air flowing for  $45 \pm 1$  min from the time the test temperature reaches  $163 \pm 1^\circ\text{C}$ .

If the test temperature of  $163^\circ\text{C}$  is not reached within the first 15 minutes, discontinue the test.

After  $45 \pm 1$  min, sample cans (minimum 2) may be removed for testing and to determine mass loss, if required. This is the Short-term Aged binder, equivalent to RTFOT, BS EN 12607-1.

To continue the Ageing Profile test, maintain the temperature at 163°C for a further 15 minutes, with the carousel rotating in the air flow, then reduce the temperature of the oven to 135 ± 1°C. Note the time the RTFO takes to reach 135°C. Once the temperature has been achieved, continue to rotate the samples in the air supply and remove sample cans to obtain samples of aged binder as required for testing after three periods:

2h ± 10min; termed **Aged<sub>2</sub> Binder**

4h ± 10min; termed **Aged<sub>4</sub> Binder**

6h ± 10min; termed **Aged<sub>6</sub> Binder**: this is the Long-term Aged Binder, equivalent to PAV85.

Other periods may be used either for convenience or to allow other degrees of ageing to be investigated.

**TABLE 9/31** (05/18) **Summary of Sampling Times**

Stage	Gas	RTFO Temperature	Time	Sampling	Cumulative time
Ageing	Air	163°C	45min	RTFOT Equivalent	45mins
	Air	163°C	15min	None	1h 00min
	Air	135°C	2h	Aged <sub>2</sub> test samples	3h 00min
	Air	135°C	4h	Aged <sub>4</sub> test samples	5h 00min
	Air	135°C	6h	Aged <sub>6</sub> test samples (equivalent to PAV85)	7h 00min

For binders used to manufacture ‘Warm Asphalt’, ‘Short Term Ageing’ at 163°C is not required, therefore, replace 163°C by 135°C in Table 9/31 and report in addition Aged<sub>1</sub> result (ageing at 135°C after a cumulative time of 1h ± 5min).

(05/18) **Handling of the Aged Binder**

**10** (05/18) If the binder is to be tested immediately, remove a sample can from the carousel, extract the screw using a small spatula and set the screw aside for cleaning. Place the sample can(s) in an oven preheated to the softening point of the binder plus 100°C (if known), or 170°C if the properties of the binder are unknown, for 20 ± 5min.

Place the containers on their sides in an oven. This allows the binder to drain to one side of the container, which is more easily removed with the spatula.

At the end of 20 ± 5min, remove the sample can from the oven, unscrew the lid and, using the spatula, scrape the aged binder from the sample can and prepare the test samples in accordance with the relevant test method. Warming the spatula to the same temperature as the binder facilitates removal of the binder.

If the aged binder from more than one sample can is needed to produce a test sample, combine the aged binder from the sample cans and re-heat. Re-heating for testing shall be in accordance with BS EN 12594, ensuring that aged binder is heated for no longer than is absolutely necessary. The binder shall be thoroughly homogenized by stirring after heating and before being used for testing, while taking care not to entrain any air.

If the binder is not to be tested immediately, remove a sample can from the RTFO, extract the screw using a small spatula and set the screw aside for cleaning. Unscrew the lid and, using the spatula, scrape the aged binder from the sample can and place on a silicon sheet. The binder shall be sealed and stored at between 0°C to 5°C. The sample shall be re-heated in accordance with BS EN 12594 and homogenised immediately before testing.

If the aged samples are to be transferred to another laboratory for testing, they shall not be subjected to temperatures greater than ambient after ageing and before testing, and the delay before testing shall not exceed 120 hours.

The thermal history of the sample shall be recorded.

(05/18) **Principle of the Ageing Profile Test for Polymer Modified or Unmodified Bituminous Emulsions or Fluxed Binders**

**11** (05/18) A thin film of binder is rotated in aluminium sample cans with screw top lids, both coated internally with PTFE (replacing glass bottles), using the RTFOT apparatus, as described in BS EN 12607-1, to evaporate water from bituminous emulsions and/or the light solvent or highly volatile fraction from fluxed or other binders. Special screws are used to disturb the binder and maintain a homogenous material during breaking and/or curing. Nitrogen gas instead of air is jetted over the film of bituminous binder at a lower temperature in order to minimize ageing effects and simulate the condition of the binder soon after application. The first part of the process is carried out with the RTFO set at 85°C to prevent frothing of the binder. The temperature is then increased to 135°C to drive off any remaining water and/or solvent to provide the 'Recovered Binder', which is equivalent to the recovered binder obtained from BS EN 13074-1. The 'Ageing Profile' is provided by continuing the ageing of the binder in the RTFO at 135°C, replacing the nitrogen gas with air and removing samples after specified periods for testing.

(05/18) **Test Procedure for Recovery and Ageing of Bituminous Emulsion and Fluxed Binders**

**12** (05/18) Obtain a sample in accordance with BS EN 58. Stir the sample thoroughly to ensure it is completely homogenized. The temperature of the binder sample shall not be less than 70% of the normal application temperature in degrees Celsius and shall be recorded (for example, high binder content surface dressing emulsion may require a minimum of 60°C, or a polymer modified fluxed binder, 130°C). The sample history if known shall be recorded; this is important, as some ageing may have occurred. If sub-samples are taken these shall have a minimum volume of 250ml. Ensure that the oven is level so that the horizontal axes of the sample cans, when in position in the carriage, are level. Pre-heat the oven to  $85 \pm 1^\circ\text{C}$ , 1h is generally sufficient.

Insert a stainless steel screw into each of the sample cans with the tapered end of the screw towards the aperture of the container and record the mass of each assembly to 0.1g. Heat the sample cans, lids and the stainless steel screws to  $85 \pm 1^\circ\text{C}$  for  $90 \pm 10$ min.

Heat the sample to the application temperature of the binder, or, if this is not known, to  $60 \pm 3^\circ\text{C}$ . Thoroughly stir the sample to ensure homogeneity immediately prior to decanting into the sample cans, taking care to minimise loss of water content and/or any volatile oil. Some cut-back binders and other binders such as primers having low flash points are not suitable for this test. If there is any doubt concerning the volatile nature of the sample for test, a suitable flash point test must be carried out before proceeding with the 'Ageing Profile test' or heating to 60°C.

Pour  $19.0 \pm 0.5$ g of the sample into a preheated sample can and record the mass. Immediately after weighing, roll the containers to ensure distribution of the binder round the bottle.

Mount the sample can in the carousel of the RTFO. Repeat for the remaining sample cans. Close the door of the RTFO between mounting each sample can in the carousel. The period between weighing the first sample can with binder and mounting of all the sample cans and the start of the rotation of the carousel shall not exceed 20 minutes.

When the carousel is fully loaded, rotate the carriage assembly at a speed of  $15.0 \pm 0.2\text{min}^{-1}$ . Start the flow of nitrogen at a set rate of  $4000 \pm 200\text{ml/min}$ . Start the timer. Maintain the samples in the oven and the nitrogen flowing for  $75 \pm 1$ min from the time the test temperature reaches 85°C. At this stage there may still be residual water in emulsion binders, especially those with high polymer contents.

If the test temperature of 85°C is not reached within the first 10 minutes, discontinue the test.

Increase the temperature of the oven to  $135 \pm 1^\circ\text{C}$ . Note the time the RTFO takes to reach 135°C. Once the temperature has been achieved, continue to rotate the carousel for a further  $30 \pm 1$ min at 135°C. At the end of the 30 minutes, turn off the nitrogen. If required, sample cans may be removed and the samples may be used for testing or determination of mass loss. This is the 'Recovered Binder' and is equivalent to that obtained using BS EN 13074-1.

The Ageing Profile can be determined by maintaining the RTFO at 135°C and switching to an air supply set at  $4000 \pm 200\text{ml/min}$ .

Rotate the samples in the air supply and remove sample cans to obtain samples of aged binder as required for testing after three periods:

3h ± 10min; termed **Aged<sub>3</sub> Binder**

5h ± 10min; termed **Aged<sub>5</sub> Binder**, and

22h ± 10min, termed **Aged<sub>22</sub> Binder**

Other periods may be used either for convenience or to allow different degrees of ageing to be investigated. Long-term Ageing equivalent to PAV85 has been found to occur at 22 hours. It takes longer to achieve than with asphalt binder, because there is no short-term ageing at 163°C. The PAV85 ageing period is not thought to be relevant for emulsion binders used in most road applications. If samples at 22 hours are not required to simulate PAV85, a combined sample from three sample cans may be useful at 3 and 5 hours, or another aged sample from two cans, say at 4 hours, may be obtained for test to enhance the 'Ageing Profile'

**TABLE 9/32 (05/18) Summary of Sampling Times**

Stage	Gas	RTFO Temperature	Time	Sampling	Cumulative time
Recovery	Nitrogen	85°C	75±1min	none	1h 15min
	Nitrogen	Ramp to 135°C	20min approx	none	1h 35min
	Nitrogen	135°C	30±1min	'Recovered binder' test samples	2h 05min
Ageing	Air	135°C	3h	Aged <sub>3</sub> test samples	5h 05min
	Air	135°C	5h	Aged <sub>5</sub> test samples	7h 05min
	Air	135°C	22h (optional)	Aged <sub>22</sub> test samples	24h 05min

**(05/18) Handling of the Recovered Binder**

**13** (05/18) If the binder is to be tested immediately, remove a sample can from the carousel, extract the screw using a small spatula and set the screw aside for cleaning. Immediately transfer the sample can (s) to an oven and heat until at the required test temperature. Place the containers on their sides in an oven. This allows the binder to drain to one side of the container, which is more easily removed with the spatula.

Unscrew the lid of the sample can and, using the spatula, scrape the recovered binder from the sample can and place in the test apparatus. Warming the spatula to 135°C facilitates removal of the binder.

If the recovered binder from more than one sample can is needed to produce a test sample, combine the recovered binder from the sample cans and re-heat. Re-heating for testing shall be in accordance with BS EN 12594, ensuring that recovered binder is heated for no longer than is absolutely necessary. The recovered binder shall be thoroughly homogenized by stirring after heating and before being used for testing, while taking care not to entrain any air.

If the recovered binder is not to be tested immediately, remove a sample can from the RTFO, extract the screw using a small spatula and set the screw aside for cleaning. Unscrew the lid and, using the spatula, scrape the recovered binder from the sample can and place on a silicon sheet. The binder shall be sealed and stored at between 0°C to 5°C. The sample shall be re-heated in accordance with BS EN 12594 and homogenised immediately before testing.

If the recovered samples are to be transferred to another laboratory for testing, they shall not be subjected to temperatures greater than ambient after recovery and before testing, and the delay before testing shall not exceed 120 hours.

The thermal history of the sample shall be recorded.

(05/18) **Handling of the Aged Binder**

**14** (05/18) If the binder is to be tested immediately, remove a sample can from the carousel, extract the screw using a small spatula and set the screw aside for cleaning. Place the sample can (s) in an oven preheated to the softening point of the binder plus 100°C (if known), or 170°C if the properties of the binder are unknown, for 20 ± 5min. Place the sample cans on their sides in an oven. This allows the binder to drain to one side of the sample can, which is more easily removed with the spatula.

At the end of 20 ± 5min, remove the sample can from the oven, unscrew the lid and, using the spatula, scrape the aged binder from the sample can and prepare the test samples in accordance with the relevant test method. Warming the spatula to the same temperature as the binder facilitates removal of the binder.

If the aged binder from more than one sample can is needed to produce a test sample, combine the aged binder from the containers and re-heat. Re-heating for testing shall be in accordance with BS EN 12594, ensuring that aged binder is heated for no longer than is absolutely necessary. The binder shall be thoroughly homogenized by stirring after heating and before being used for testing, while taking care not to entrain any air.

If the binder is not to be tested immediately, remove a sample can from the RTFO, extract the screw using a small spatula, and set the screw aside for cleaning. Unscrew the lid and, using the spatula, scrape the aged binder from the sample can and place on a silicon sheet. The binder shall be sealed and stored at between 0°C to 5°C. The sample shall be re-heated in accordance with BS EN 12594 and homogenised immediately before testing.

If the aged samples are to be transferred to another laboratory for testing, they shall not be subjected to temperatures greater than ambient after ageing and before testing, and the delay before testing shall not exceed 120 hours.

The thermal history of the sample shall be recorded.

(05/18) **Principle of Assessing the Action of Preservatives using the MRTFOT**

**15** (05/18) A thin film of 40/60 penetration grade binder is rotated in aluminium sample cans, coated internally with PTFE (replacing glass bottles), using the Rolling Thin Film Oven Test (RTFOT) apparatus, as described in BS EN 12607-1. Special screws are used to disturb the binder and maintain a homogenous material during conditioning. The bitumen is subjected to 'Short-term Ageing' followed by an extended period in the RTFO to simulate the ageing of the bitumen in a road pavement. The properties of the 'Long-term Aged' bitumen may be determined at this stage. The aged bitumen control in the remaining samples is then cooled to ambient, treated with the preservative and left for 24 hours. Most of the remaining highly volatile oils are subsequently removed by conditioning the samples in the RTFO using a nitrogen blanket. The aged bitumen, treated by preservative, is then subjected to further ageing with the Modified RTFO. The properties of the aged bitumen, after action of the preservative, are assessed by an 'Ageing Profile' test, using rheology values of complex shear (stiffness) modulus  $G^*$  and phase angle  $\delta$ , in accordance with BS EN 14770. Cohesion durability may also be determined.

(05/18) **Test Procedure for Determining the 'Ageing Profile' of Aged Paving Grade Bitumen as a Control Treated with a Preservative**

**16** (05/18) Obtain a sample of 40/60 paving grade binder in accordance with BS EN 58. Stir the sample thoroughly to ensure it is completely homogenized. If sub-samples are taken these shall have a minimum volume of 250ml. Ensure that the RTFO is level so that the horizontal axes of the sample cans when in position in the carousel are level. Pre-heat the oven to 163 ± 1°C, 1h is generally sufficient.

Insert a weighed stainless steel screw into each of the sample cans with the tapered end of the screw towards the aperture of the can lid; record the mass of each assembly to 0.1g. Heat the sample cans, lids and the stainless steel screws to 163 ± 1°C for 90 ± 10min.

Heat the sample to the maximum storage temperature of the binder. Thoroughly stir the sample to ensure homogeneity immediately prior to decanting into the sample cans.

Pour 19.0 ± 0.5g of the sample into a preheated sample can and record the mass. Immediately after weighing, roll the sample can on the bench to ensure distribution of the binder round the walls of the can.

Mount the sample can in the carousel of the RTFO. Repeat for the remaining sample cans. Close the door of the RTFO between mounting each sample can in the carousel. The period between weighing the first sample can with binder and mounting of all the sample cans and the start of the rotation of the carousel shall not exceed 20 minutes.

When the carousel is fully loaded, rotate the carriage assembly at a speed of  $15.0 \pm 0.2 \text{ min}^{-1}$ . Start the flow of air at a set rate of  $4000 \pm 200 \text{ ml/min}$ . Start the timer. Maintain the samples in the oven and the air flowing for  $45 \pm 1 \text{ min}$  from the time the test temperature reaches  $163^\circ\text{C}$ .

If the test temperature of  $163^\circ\text{C}$  is not reached within the first 10 minutes, discontinue the test.

After  $45 \pm 1 \text{ min}$  at  $163 \pm 1^\circ\text{C}$ , sample cans (minimum 2) shall be removed for testing and to determine mass loss. This is the 'Short-term Aged Binder'.

Reduce the temperature of the oven to  $135 \pm 1^\circ\text{C}$ . Note the time the RTFO takes to reach  $135^\circ\text{C}$ . Once this temperature has been achieved, continue to rotate the samples in the air supply for  $240 \pm 10 \text{ min}$ . At the end of this period, remove the sample cans from the RTFO and determine their mass loss.

Remove the screws and weigh to determine the mass of binder retained on each identified screw.

A quantity of binder shall be removed from each sample can, which shall be:  
 $8 \pm 1 \text{ g}$ , less the mass of binder retained on the particular screw removed.

It may be necessary to warm the sample cans to facilitate the removal of the screws and binder.

After removing the binder, lay the sample cans on their sides and allow them to cool to ambient temperature.

Add  $10 \pm 0.5 \text{ g}$  of preservative to each sample container and swirl the preservative around the sample container for approximately 15 seconds. Determine the mass of each sample can.

The sample cans with the binder and preservative are stored on their sides, with the pooled binder at the bottom, in a ventilated fume cupboard at ambient temperature for 24 hours. This process allows any very low flashpoint volatile oil to safely evaporate and consequently reduce the amount of hydrocarbon solvent within the sample can.

Pre-heat the oven to  $50 \pm 1^\circ\text{C}$ , and transfer the sample cans from the fume cupboard to the RTFO carousel. Start the carousel and jet nitrogen at  $4000 \pm 200 \text{ ml/min}$  over the sample cans for  $120 \pm 10 \text{ min}$ .

Identify and weigh eight clean screws and heat the screws to  $135^\circ\text{C}$ .

After 2 hours, the RTFO temperature is raised from  $50^\circ\text{C}$  to  $135^\circ\text{C}$  and air jetted at  $4000 \pm 200 \text{ ml/min}$  substituted for the nitrogen supply. Note the time when the oven achieves  $135^\circ\text{C}$ .

When the RTFO has reached  $135^\circ\text{C}$ , stop the carousel and add a preheated screw to each sample can, with the tapered end of the screw towards the aperture/lid of the sample can (and noting which screw is added to which sample can). Restart the carousel and continue the conditioning of the samples at  $135^\circ\text{C}$  in air jetted at  $4000 \pm 200 \text{ ml/min}$  for  $120 \pm 10 \text{ min}$ .

Remove the sample cans from the RTFO to obtain samples of aged binder as required for testing and determine the mass of each sample can.

The control bitumen may be substituted with a binder recovered from a road or from a laboratory aged sample, in which case the 'Short-term Ageing' and subsequent ageing protocol are not carried out, because the binder will already have been aged and heated. In this case, the recovered binder sample is heated in accordance with BS EN 12594 and  $11 \pm 0.5 \text{ g}$  added to heated cans ( $135^\circ\text{C}$ ) which are then rolled to achieve a film around the walls. After this, they are cooled,  $10 \pm 0.5 \text{ g}$  preservative added and the preservative treated samples subjected to the same Ageing Profile protocol as described above.

#### (05/18) Handling of the Preservative Treated Aged Bitumen

**17** (05/18) If the binder is to be tested immediately, remove a container from the carousel, extract the screw using a small spatula and set the screw aside for cleaning. Place the sample can (s) in an oven preheated to  $140^\circ\text{C}$  for  $20 \pm 5 \text{ min}$ . Place the containers on their sides in the oven. This allows the binder to drain to one side of the container, which is more easily removed with the spatula.

At the end of  $20 \pm 5$  min, remove the container from the oven, unscrew the lid and, using the spatula, scrape the aged binder from the container and prepare the test samples in accordance with the relevant test method. Warming the spatula to the same temperature as the binder facilitates removal of the binder.

If the aged binder from more than one container is needed to produce a test sample, combine the aged binder from the containers and re-heat. Re-heating for testing shall be in accordance with BS EN 12594, ensuring that aged binder is heated for no longer than is absolutely necessary. The binder shall be thoroughly homogenized by stirring after heating and before being used for testing, while taking care not to entrain any air.

If the binder is not to be tested immediately, remove a container from the RTFO, extract the screw using a small spatula and set the screw aside for cleaning. Unscrew the lid and, using the spatula, scrape the aged binder from the container and place on a silicone sheet. The binder shall be sealed and stored at between  $0^{\circ}\text{C}$  to  $5^{\circ}\text{C}$ . The sample shall be re-heated in accordance with BS EN 12594 and homogenised immediately before testing.

If the aged samples are to be transferred to another laboratory for testing, they shall not be subjected to temperatures greater than ambient after ageing and before testing, and the delay before testing shall not exceed 120 hours.

The thermal history of the sample shall be recorded.

#### (05/18) Report

**18** (05/18) Sample description (e.g. type, age/condition and source).

The Ageing Profile test procedure adopted for the work.

The change in mass of the sample from each stage of the recovery and /or ageing protocol shall be plotted to develop an Ageing Profile for mass change.

Similarly, results of tests (for example  $G^*$  using BS EN 14770), carried out after each stage of recovery and /or ageing protocol, shall be plotted to develop an Ageing Profile for that property. These results shall include:

- A plot of  $G^*$  (0.4Hz) over a range of temperatures between  $0^{\circ}\text{C}$  and  $60^{\circ}\text{C}$
- A plot of phase angle (0.4Hz) over a range of temperatures between  $0^{\circ}\text{C}$  and  $60^{\circ}\text{C}$
- $G^*$  and phase angle at 0.4Hz and  $25^{\circ}\text{C}$
- Temperature (0.4Hz) where the phase angle is 45 degrees (Viscous Elastic Transition (VET) temperature)
- $G^*$  (0.4Hz) at the VET temperature where phase angle is 45 degrees

For Clause 930 hard grade binder samples and other samples where they are considered to have a softening point above  $60^{\circ}\text{C}$  the temperature range shall be increased to  $80^{\circ}\text{C}$ .

The thermal history of the samples, if they are not tested immediately, shall be reported.

**956 & 957** (05/18) **Not used**

**958** (05/18) **Modified Binder Storage Stability Test**

#### (05/18) Scope

**1** (05/18) This test determines the susceptibility of a preblended modified binder to separation or instability during prolonged storage at high temperature.

(05/18) **Summary of Method**

2 (05/18) A sample of modified binder shall be contained in a closed vessel of specific dimensions and shall be maintained at  $160 \pm 2^\circ\text{C}$  for 7 days  $\pm$  2 hours. A binder sample shall then be taken from the top and bottom thirds of the vessel and both samples shall be tested for compliance with the binder specification.

(05/18) **Apparatus**

3 (05/18) The apparatus shall consist of:

- (i) Cylinder, made of heat resistant glass,  $190 \pm 30$  mm long and  $65 \pm 5$  mm internal diameter having a removable lid, flush fitting to exclude air when the cylinder is filled with binder, and provided with three drain valves, one at the base, the other two spaced equally down the side of the cylinder, to allow the sample to be divided into three equal portions as in sub-Clause 4 (vii) of the procedure.

Alternatively, a thin-wall sheet metal tube or similar vessel such as a 500 ml beverage can, of similar dimensions to the glass cylinder, and having a similarly removable lid, fitted either with or without drain-valves.

- (ii) Oven, electrically heated, fan assisted, and capable of maintaining a temperature of  $160 \pm 2^\circ\text{C}$ , having interior dimensions not less than 330 mm from the top of the heating element to the top of the chamber and not less than 305 mm in width and depth.
- (iii) Tube holder, made of metal, that will hold either the glass cylinder or sheet metal can, in a vertical position, such that the base of the cylinder or can is not in direct contact with the oven floor.
- (iv) Apparatus for determining the penetration and softening point of bitumen in accordance with BS EN 1426 and BS EN 1427.
- (v) Transfer dishes (3), made of metal, each of a capacity sufficient to hold at least one-third of the test sample.

(05/18) **Test Procedure**

4 (05/18) The procedure shall be as follows:

- (i) The bulk sample of modified binder shall be obtained by sampling in accordance with BS EN 58.
- (ii) Place the bulk sample of modified binder and the glass cylinder (or metal tube or equivalent vessel) in the preheated oven at  $160 \pm 2^\circ\text{C}$  for a period not exceeding  $3.75 \pm 0.25$  hours.
- (iii) Remove the bulk sample from the oven and thoroughly mix by stirring to ensure obtaining a representative test sample.
- (iv) Remove the glass cylinder (or metal tube or equivalent vessel) from the oven and completely fill with the modified binder test sample to allow no air space when the lid is fitted.
- (v) Support the filled cylinder in a vertical position in the holder and transfer to the oven which shall be controlled at a temperature of  $160 \pm 2^\circ\text{C}$  and allow to stand undisturbed for a period of  $168 \pm 2$  hours.
- (vi) If a vessel having drain-valves has been used for the test proceed using Method A below, otherwise proceed using Method B.
- (vii) **Method A**
  - (a) Remove the glass cylinder (or alternative approved vessel) from the oven, keeping the cylinder vertical.
  - (b) Open the uppermost drain-valve and run off the top third portion of the test sample into a transfer dish for testing.

- (c) Open the middle drain-valve and run off the middle third portion of the test sample into a suitable container and discard.
- (d) Open the lower drain-valve and run off the bottom third portion of the test sample into a transfer dish for testing.

(viii) **Method B**

- (a) Remove the tube or vessel containing the test sample from the oven and allow it to cool at room temperature for  $2 \pm 0.25$  hours whilst maintaining the vessel vertical in the holder.
  - (b) When the vessel of modified binder has cooled to ambient temperature, remove it from the tube holder and make two cuts through the vessel and the sample at positions one-third and two-thirds of the length from, and parallel, to the base.
  - (c) Retain the top and bottom thirds of the test sample for further testing and discard the middle third.
- (ix) Determine the penetrations and softening points of the top and bottom thirds of the test sample, in accordance with BS EN 1426 and BS EN 1427.

(05/18) **Reporting**

**5** (05/18) For both the top and bottom thirds of the test sample the following shall be reported:

- (i) The penetration, to BS EN 1426.
- (ii) The softening point, to BS EN 1427.
- (iii) Whether Method A or Method B was used.
- (iv) The location and date of obtaining the bulk sample, and the dates of test.

# NATIONAL ALTERATIONS OF THE OVERSEEING ORGANISATION OF SCOTLAND

## 908TS (07/21) Warm Mix Asphalt (WMA)

### (07/21) WMA General

1 (07/21) WMAs shall be installed in accordance with the producer's instructions.

### (07/21) WMA Permitted Mixtures

2 (07/21) Mixtures produced as Warm Mix Asphalts shall fulfil the requirements given in:

- (iii) Clause 906 for Dense Base and Binder Course Asphalt Concrete with Paving Grade Bitumen (Recipe Mixtures);
- (iv) Clause 912 for Close Graded Asphalt Concrete Surface Course;
- (iii) Clause 929 for Dense Base and Binder Course Asphalt Concrete (Design Mixtures);
- (iv) Clause 930 for EME2 Base and Binder Course Asphalt Concrete;
- (v) Clause 937 for Stone Mastic Asphalt (SMA) Binder Course and Regulating Course;
- (vi) Clause 942TS for Thin Surface Course Systems; and
- (vii) Clause 901 and Clause 903 and contract specific Appendix 7/1.

3 (07/21) Warm mixtures conforming to Clause 942TS shall have Product Acceptance Scheme certification for their installation in compliance with sub-Clause 104.16 and Clause 942TS to demonstrate their performance.

4 (07/21) For the purposes of traceability, the mixture designation shall include a reference to the use of warm mix technologies e.g AC20 bin HDM 40/60 "W".

### (07/21) WMA Production Temperatures

5 (07/21) The maximum production temperatures, when measured in accordance with BS EN 12697-13, shall be in accordance with Table 9/1A and the material's Declaration of Performance and not compromise the efficacy of the binder, additives or process.

**Table 9/1A TS (07/21) Maximum production temperatures for WMAs incorporating paving grade binders, hard paving grade binders or Polymer Modified Binders**

Binder grade	Maximum Temperature (°C) (at any stage)
Paving grade conforming to BS EN 12591	150
Hard paving grade conforming to BS EN 13924-1	160
Polymer Modified Binder conforming to BS EN 14023	Documented and declared by the producer

### (07/21) Water Sensitivity

6 (07/21) Unless otherwise stated in contract specific Appendix 7/1, the water sensitivity expressed as an Indirect Tensile Strength Ratio or Compression strength ratio shall be in accordance with Table 9/1B and contract specific Appendix 7/1 and be declared on the Declaration of Performance.

7 (07/21) Designated WMA mixtures in Table 9/1B which include 2% hydrated lime filler aggregate are deemed to result in mixtures which satisfy water sensitivity requirements and testing is not required. Hydrated lime filler shall be  $\text{Ca}(\text{OH})_2$  in the form of hydrated lime, type CL 90-S.

**Table 9/1B TS (07/21) Minimum Water Sensitivity Values for Warm Mix Asphalts**

Material Clause and Description	SHW Clause	ITSR <sub>min</sub>	BS EN 12697 12 Test Method
Dense Base and Binder Course Asphalt Concrete (Design Mixtures)	929	80	A
Stone Mastic Asphalt (SMA) Binder Course and Regulating Course	937		
Thin Surface Course Systems	942		
EME2 Base and Binder Course Asphalt Concrete	930	See sub-clause 930.21	B

**(07/21) WMA Installation**

8 (07/21) Mixtures produced as WMA shall comply with the requirements in Clause 903, contract specific Appendix 7/1, Table 9/1C and the producer's recommendations and not compromise the efficacy of the WMA binder, additives or process.

**Table 9/1C TS (07/21) Minimum Rolling Temperatures for WMAs Incorporating Paving Grade Binders, Hard Paving Grade Binders or Polymer Modified Binders**

Binder grade	Minimum Temperature (°C) (immediately prior to rolling)
Paving grade conforming to BS EN 12591	90
Hard paving grade conforming to BS EN 13924-1	110
Polymer Modified Binder conforming to BS EN 14023	Documented and declared by the producer

**911TS (07/21) Hot Rolled Asphalt Surface Course (Design Mixtures)**

1 (05/18) Hot Rolled Asphalt surface course design mixes shall conform to BS EN 13108-4, the example in BSI PD 6691 Annex C and requirements specified in contract specific Appendix 7/1. The mixture designation shall be one of the following:

- (i) HRA 0/2 F surf xx/yy des
- (ii) HRA 30/14 F surf xx/yy des
- (iii) HRA 35/14 F surf xx/yy des
- (iv) HRA 55/10 F surf xx/yy des
- (v) HRA 55/14 F surf xx/yy des
- (vi) HRA 0/2 C surf xx/yy des

- (vii) HRA 30/14 C surf xx/yy des
- (viii) HRA 35/14 C surf xx/yy des
- (ix) HRA 55/10 C surf xx/yy des
- (x) HRA 55/14 C surf xx/yy des

Unless otherwise specified in contract specific Appendix 7/1, the grade of bitumen required (xx/yy) shall be 40/60.

**(05/18) Coarse Aggregate**

**2** (05/18) The resistance to polishing of the coarse aggregate for chipped mixtures shall be category PSV<sub>44</sub> as defined in BS EN 13043:2002, clause 4.2.3. For unchipped mixtures, the coarse aggregate shall have a minimum declared PSV and a maximum declared AAV as specified in contract specific Appendix 7/1.

**(05/18) Coated Chippings**

**3** (05/18) When required, coated chippings shall be either 14/20 mm or 8/14 mm size in accordance with BSI PD 6682-2, as specified in contract specific Appendix 7/1. Coated chippings shall also comply with Clause 915.

**(05/18) Marshall Stability and Flow**

**4** (05/18) When required, the Marshall stability and flow of the mixture at the target binder content shall be as specified in contract specific Appendix 7/1. Stability and flow values shall be determined in accordance with the procedures in BS 594987, Annex H.

**942TS (07/21) Stone Mastic Asphalt Surface Course**

**1** (07/21) SMA TS2010 specification shall be as per Chapter 2 of TS2010 Surface Course Specification & Guidance Issue 4 (November 2018), or subsequent issue, available from Transport Scotland Asset Management Branch.

# NATIONAL ALTERATIONS OF THE OVERSEEING ORGANISATION OF WALES

## 908WG (07/21) Warm Mix Asphalt (WMA)

1 (07/21) Warm Mix Asphalt shall not be used.

## 911WG (07/21) Hot Rolled Asphalt Surface Course (Design Mixtures)

1 (05/18) Hot Rolled Asphalt surface course design mixes shall conform to BS EN 13108-4, the example in BSI PD 6691 Annex C and requirements specified in contract specific Appendix 7/1. The mixture designation shall be one of the following:

- (i) HRA 0/2 F surf xx/yy des
- (ii) HRA 30/14 F surf xx/yy des
- (iii) HRA 35/14 F surf xx/yy des
- (iv) HRA 55/10 F surf xx/yy des
- (v) HRA 55/14 F surf xx/yy des
- (vi) HRA 0/2 C surf xx/yy des
- (vii) HRA 30/14 C surf xx/yy des
- (viii) HRA 35/14 C surf xx/yy des
- (ix) HRA 55/10 C surf xx/yy des
- (x) HRA 55/14 C surf xx/yy des

Unless otherwise specified in contract specific Appendix 7/1, the grade of bitumen required (xx/yy) shall be 40/60.

### (05/18) Coarse Aggregate

2 (05/18) The resistance to polishing of the coarse aggregate for chipped mixtures shall be category PSV<sub>44</sub> as defined in BS EN 13043:2002, clause 4.2.3. For unchipped mixtures, the coarse aggregate shall have a minimum declared PSV and a maximum declared AAV as specified in contract specific Appendix 7/1.

### (05/18) Coated Chippings

3 (05/18) When required, coated chippings shall be either 14/20 mm or 8/14 mm size in accordance with BSI PD 6682-2, as specified in contract specific Appendix 7/1. Coated chippings shall also comply with Clause 915.

### (05/18) Marshall Stability and Flow

4 (05/18) When required, the Marshall stability and flow of the mixture at the target binder content shall be as specified in contract specific Appendix 7/1. Stability and flow values shall be determined in accordance with the procedures in BS 594987, Annex H.

**942WG (07/21) Welsh Government Procedure and Advice Guidance (PAG) 112/20 – Stone Mastic Asphalt Specification.**

1 (07/21) WG Stone Mastic Asphalt (SMA) surface course shall be as specified in PAG 112/20 issue 02 or any subsequent issue, available via:

<https://gov.wales/sites/default/files/publications/2020-09/procedure-and-advice-guidance-pag-112-20-stone-mastic-asphalt-specification.pdf>

SUPERSEDED

## NATIONAL ALTERATIONS OF THE OVERSEEING ORGANISATION OF NORTHERN IRELAND

### 908NI (07/21) Warm Mix Asphalt (WMA)

- 1 (07/21) Warm Mix Asphalt shall not be used without prior approval from the Overseeing Organisation.

SUPERSEDED