

---

**VOLUME 1 HIGHWAY  
STRUCTURES:  
APPROVAL  
PROCEDURES AND  
GENERAL DESIGN**

**SECTION 3 GENERAL DESIGN**

---

**PART 13**

**BA 53/94**

**BRACING SYSTEM AND THE USE OF U-  
FRAMES IN STEEL HIGHWAY BRIDGES**

**SUMMARY**

This Advice Note is intended to provide guidance on the design of bracing systems and the use of U-frames in steel composite highway bridges and structures.

**INSTRUCTIONS FOR USE**

This is a new document to be incorporated into the Manual.

1. Insert BA 53/94 into Volume 1, Section 3.
2. Remove contents page dated May 1994 and insert page dated December 1994.
3. Archive this sheet as appropriate

Note: The new contents page (dated December 1994) replaces the page which was not to be made available with BD 57/94. BD 57/94, BA 57/94 and BA 42/94 will not now be available until February/March 1995.



THE HIGHWAYS AGENCY

BA 53/94



THE SCOTTISH OFFICE INDUSTRY DEPARTMENT



THE WELSH OFFICE  
Y SWYDDFA GYMREIG



THE DEPARTMENT OF  
THE ENVIRONMENT FOR NORTHERN IRELAND

# Bracing Systems and the Use of U-Frames in Steel Highway Bridges

**Summary:** This Advice Note is intended to provide guidance on the design of bracing systems and the use of U-frames in steel composite highway bridges and structures.

REGISTRATION OF AMENDMENTS

Amend No	Page No	Signature & Date of incorporation of amendments	Amend No	Page No	Signature & Date of incorporation of amendments

WITHDRAWN

REGISTRATION OF AMENDMENTS

Amend No	Page No	Signature & Date of incorporation of amendments	Amend No	Page No	Signature & Date of incorporation of amendments

WITHDRAWN

---

VOLUME 1 HIGHWAY  
STRUCTURES:  
APPROVAL  
PROCEDURES AND  
GENERAL DESIGN  
SECTION 3 GENERAL DESIGN

---

**PART 13**

**BA 53/94**

**BRACING SYSTEM AND THE USE  
OF U-FRAMES IN STEEL HIGHWAY  
BRIDGES**

**Contents**

Chapter

1. Introduction
2. Definitions
3. Braced I-Beam Bridges
4. The Use of BS 5400 Part 3
5. Continuous Composite Deck Type Bridges
6. Skew Bridges
7. Bracing System During Construction
8. Fatigue
9. References and Bibliographies
10. Enquiries

Annex A: Figures

# 1. INTRODUCTION

## General

1.1 This Advice Note gives guidelines on the design of bracing systems and U-frames for steel and composite highway bridges and footbridges. It is based on the findings and recommendations of a desk study on the topic carried out for the Department of Transport.

## Scope

1.2 This Advice Note is applicable to the design and assessment of steel only and steel-concrete composite bridges.

1.3 Any reference in this Advice Note to a British Standard is to that standard as implemented by the appropriate DMRB Standard.

## Implementation

1.4 This Advice Note should be used forthwith on all schemes for the construction, improvement and maintenance and all assessments of steel and composite bridges currently being prepared provided that, in the opinion of the Overseeing Organisation, this would not result in significant additional expense or delay progress. Its application to particular schemes and assessments should be confirmed with the Overseeing Organisation.

## 2. DEFINITIONS

- 2.1 Bracing system. The strength of compression members and I beams may be limited by buckling. A bracing system is the structural means to restrain members from buckling and lateral instability.
- 2.2 Effective bracing system. An effective bracing system should provide sufficient stiffness to the member so that buckling or lateral instability does not occur at the ultimate limit state.
- 2.3 Effective discrete lateral restraint. This is the lateral restraint at discrete points with sufficient stiffness such that the effective length can be taken as the length between the points.
- 2.4 Flexible restraints. These do not have sufficient individual stiffness to provide effective discrete intermediate lateral restraints at brace locations.
- 2.5 Plan bracing. This is defined as a horizontal triangular framework or a decking system which is capable of transferring the restraint forces to the support.

### 3. BRACED I-BEAM BRIDGES

3.1 Steel I-beams in bridges are often intermediately braced within the span to provide a braced structure. The presence of initial imperfections and the flexibility of the braced structure give rise to displacement of the whole system when the beams are subjected to bending. This displacement causes additional lateral bending and torsional stresses in the beam and forces in the bracing members. The beam bracing therefore needs to be designed to provide sufficient stiffness by restricting lateral and torsional deformation to prevent overstress in the beam and the bracing.

3.2 Various types of bracing systems can be provided to restrain steel I-beams and in general they fall into the following categories:

- (a) The compression flange is restrained directly by the deck or by a plan triangulated framework. This includes simply supported deck type bridges with concrete slab on top of the beams (see Figures 1a and 1b).
- (b) The compression flange is restrained by flexible restraints in the form of intermediate U-frames with a plan triangulated framework or a decking system at the level of the cross members of the U-frame. This includes half through type bridges and the hogging moment regions of deck type bridges where inverted U-frames are provided (see Figures 2a and 2b).
- (c) The beam is restrained by effective discrete lateral restraints or intermediate stiff bracing which provides effective lateral torsional restraint by restricting the twisting of the beam or the lateral movement of the compression flange at the bracing locations. This includes intermediate vertical triangulated frames or diaphragms which are also known as stiff torsional bracing. They are commonly used in the hogging moment regions of long span deck type bridges and bridges at construction stages (see Figure 3).
- (d) The beam is restrained by intermediate flexible bracing which does not have sufficient stiffness to provide effective lateral torsional restraint at the brace locations as described in (c) or which does not form intermediate U-frames as in (b). A typical example is a

series of parallel bracing members jointing two or more I-beams at the compression flange level forming a Vierendeel truss on plan (see Figure 4). This type of bracing provides flexible restraints and is outside the scope of BS 5400 Part 3 unless it is connected to another effective bracing system or braced structure.

3.3 For simply supported beams, any one of the systems described in (a), (b) and (c) may be used. For continuous beams, while the provision of (b) or (c) through out the whole length of the beams is sufficient, (a) is commonly supplemented by (b) or (c) at hogging moment regions.

3.4 Where a system of plan bracing as described in (a) and (b) above is provided, it should be capable of transferring the restraint forces to the supports.

3.5 The provision of stiff torsional bracing as described in (c) above should be considered where the change of direction of compression flanges occurs such as in haunched beams and in curved bridges where straight beam elements are used.

3.6 Where it is anticipated that the bridge beams will be jacked up during the life of the bridge, eg, for the replacement of bearings, consideration should be given in the design of the bracing to facilitate such operation either by removing the bracing or by designing the bracing to take the additional forces induced by the operation. The procedure for such jack up operation should be detailed in the Maintenance Manual.

## 4. THE USE OF BS5400 PART 3

### General

4.1 The procedure for the design of bracing systems in BS 5400 Part 3 can be summarized as follows:

- (a) Determine the form of the bracing system, the number and the locations of lateral restraints.
- (b) Calculate the effective length of the beam using Clause 9.6 and design the beam using the appropriate Clauses in Section 9.
- (c) Calculate the various restraint forces acting at the intermediate lateral restraints as given in Clauses 9.12.1 to 9.12.3 as appropriate. When designing the restraints, these forces should be added to the other load effects which may result from wind, temperature, longitudinal braking force, centrifugal force and other relevant forces.
- (d) Calculate the various restraint forces acting at the support as given in Clause 9.12.4.1. Add these forces to the effects of wind and other applied forces and design the support restraints. The support restraints should also satisfy the stiffness requirements as given in Clause 9.12.4.2.

4.2 Detailed background information and the derivations of some of the formulae may be found in reference 3. Their uses, difficulties encountered and alternative solutions are given in the following paragraphs.

### U-frames with flexible end posts

4.3 In calculating the effective length for beams restrained by U-frames using Clause 9.6.5, BS 5400 Part 3 assumes that the supports have sufficient stiffness to prevent the lateral movement of the compression flange so that the ends of the beam remain almost vertical. Stiffeners which comply with the stiffness requirements in Clause 9.12.4.2 are considered satisfying the assumptions. This is also known as beams with rigid end posts.

4.4 In some cases, it can be difficult to provide stiffeners which comply with Clause 9.12.4.2 and

therefore less rigid stiffeners (or so called flexible end posts) may need to be considered. When such stiffeners are used in simply supported bridges, the coefficient of 2.5 in the equation for  $l_e$  in Clause 9.6.5 may be calculated from first principle using beam on elastic foundation approach. However, the stiffeners still will need to comply with the force requirements in Clause 9.12.4.1.

### U-frames with cross members subjected to vertical loading

4.5 When vertical loading is applied to the cross member of a U-frame, the cross member deflects and generates a force,  $F_c$ , acting at the tip of the U-frame at the compression flange level. The equation for  $F_c$  in Clause 9.12.2.3 is known to be unduly conservative and, in some cases, difficult to cater for. The  $F_c$  force may be reduced if the interaction between the cross member, the vertical stiffeners and the compression flanges are taken into account.

4.6 Similarly, the value of  $F_c$  in Clause 12.5.3.1(c) may also be reduced.

## 5. CONTINUOUS COMPOSITE DECK TYPE BRIDGES

5.1 In the sagging moment region of a continuous composite deck type bridge, the compression flange is continuously restrained by the deck slab, whereas in the hogging moment region, the compression flange is usually restrained by inverted U-frames or intermediate stiff torsional bracing.

5.2 Designers should be aware that the lateral torsional buckling rules involving U-frames in BS 5400 Part 3 are derived with simply supported beams in mind and are found to be unduly conservative when applied to the hogging moment region of a continuous composite deck type bridge. It is possible to design the hogging moment region more economically by consulting specialist literature which takes into account the buckling of beams under hogging moments.

WITHHOLD DRAWMN

## 6. SKEW BRIDGES

### General

6.1 For skew bridges with widely spaced longitudinal beams, some of the cross-members may be connected to the main beams at one end and to the end trimmer over the abutment at the other end. Difficulties often arise with the design of bracing systems for this type of bridges. A few solutions are discussed in the following paragraphs.

stiffener. The choice of bearings over the abutments is the same as for skew half through type bridges.

6.7 Over intermediate supports, torsional restraints square to the beams are more effective than those parallel to the supports if the skew angle is large.

### Skew Half Through Type Bridges

6.2 At the acute corners of a skew half through bridge, the beam is restrained by L-frames. At the obtuse corners, although the beams are restrained by U-frames, the differential deflections at the ends of the cross member are much larger than that of a square bridge. Therefore the U-frame rules in BS 5400 Part 3 are not applicable to this type of bridge.

6.3 Special consideration should be given to the choice of bearings at supports. Two types of bearings are commonly used: rocker bearing and pot bearing. A rocker bearing prevents the beam from twisting and hence provides torsional restraint whereas a pot bearing allows the beam to rotate in all directions and does not provide any torsional restraint. Other types of bearings may be used provided that the engineer is satisfied that they would be able to provide the necessary restraints.

6.4 At the acute corners, the torsional restraint may be provided by using a rocker bearing, or alternatively, by the end trimmer if a pot bearing is used.

6.5 At the obtuse corners, the use of a rocker bearing should be avoided. This is because the twisting of the beam due to the cross member deflection may cause uneven stresses across the rocker bearing and the bearing stiffener.

### Skew Continuous Deck Type Bridges

6.6 For skew continuous deck type bridges, it is preferable to use pot bearings over the intermediate supports to avoid uneven stresses in the bearing

## 7. BRACING SYSTEM DURING CONSTRUCTION

7.1 At all stages of construction, the bracing system should be effective and provide the necessary stability to the structure as a whole.

7.2 It should be noted that the preservation of stability and tolerances depends on the structure stiffness and not by designing for a particular force alone. In some cases, additional bracing which are not necessary for the permanent works may be required during construction.

7.3 On many steelwork assemblies, stiff torsional bracing in the form of vertical triangulated framework between beams provides effective intermediate restraints. Such bracing is the recommended first choice.

7.4 Special consideration should be given to temporary intermediate bracing during slab concreting. For deck type bridges, additional transverse members or vertical triangulated framework may be necessary. The use of stiff vertical triangulated framework between a pair of I-beams may permit several adjacent beams to be braced from the stiff pair.

7.5 For half through type bridges where the stability of the steel beams during slab concreting also relies on the intermediate U-frames, an effective plan bracing at the level of the cross-members, e.g. in the form of plan triangulated framework, must be provided and extend to the supports. This also applies to the hogging moment region of continuous deck type bridges.

7.6 To provide torsional restraint at supports, temporary propping, additional transverse members, triangulated framework or diaphragms may be used.

## 8. FATIGUE

8.1 Fatigue in a bracing system requires close and detailed attention since stress ranges can be high due to restraints at the joints. Designers should consider the following guidelines to improve fatigue life of the structure and reduce maintenance.

- (a) Avoid unnecessary bracing as it could impose restraint causing stress concentration.
- (b) Use simple joint details and avoid joint eccentricities.
- (c) Remove temporary bracing as far as possible.
- (d) Avoid bracing systems which give excessive local stresses or attract large live load stresses.
- (e) Use welds of proper type and size.
- (f) Avoid welded attachments to elements which are subject to high stress ranges.

WITHHOLD DRAWMN

## 9. REFERENCES AND BIBLIOGRAPHIES

### References

1. Design Manual for Roads and Bridges.  
(DMRB)

Volume 1 Section 3 General Design

BD 13 Design of Steel Bridges. Use  
of BS 5400: Part 3: 1982.  
(DMRB 1.3)

BD 16 Design of Composite Bridges.  
Use of BS 5400: Part 5: 1979 (with  
Amendment No 1 dated December  
1987). (DMRB 1.3)

2. **British Standards**

BS 5400: Part 3: 1982. Steel, Concrete and  
Composite Bridges. Code of Practice for  
Design of Steel Bridges. British Standards  
Institution, 1982.

BS 5400: Part 5: 1979. Steel, Concrete and  
Composite Bridges. Code of Practice for  
Design of Composite Bridges. British  
Standards Institution, 1979.

3. **Miscellaneous**

U-frame restraint against instability of steel  
beams in bridges. *The Structural Engineer*,  
Volume 68, No 18, 18 September 1990.

## 10. ENQUIRIES

All technical enquiries or comments on this Advice Note should be sent in writing as appropriate to:

Head of Bridges Engineering Division  
The Highways Agency  
St Christopher House  
Southwark Street  
London SE1 0TE

A. J. PICKETT  
Head of Bridges Engineering Division

The Deputy Chief Engineer  
Roads Directorate  
The Scottish Office Industry Department  
New St. Andrew's House  
Edinburgh EH1 3TG

J INNES  
Deputy Chief Engineer

Head of Roads Engineering (Construction) Division  
Welsh Office  
Y Swyddfa Gymreig  
Government Buildings  
Ty Glas Road  
Llanishen  
Cardiff CF4 5PL

B H HAWKER  
Head of Roads Engineering  
(Construction) Division

Assistant Chief Engineer (Works)  
Department of the Environment for  
Northern Ireland  
Road Service Headquarters  
Clarence Court  
10-18 Adelaide Street  
Belfast BT2 8GB

D O'HAGAN  
Assistant Chief Engineer (Works)

# FIGURES

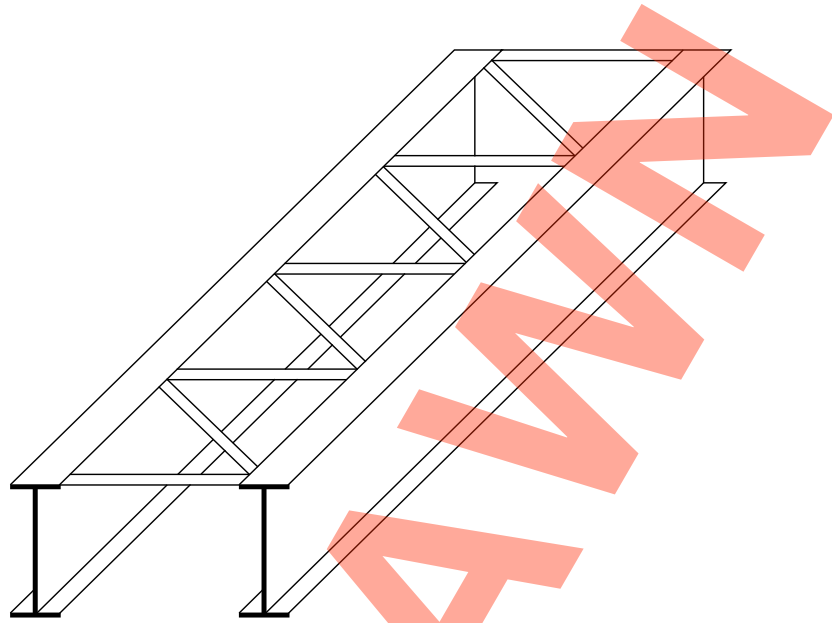

Figure 1 (a) Compression flange restrained by a plan triangulated framework

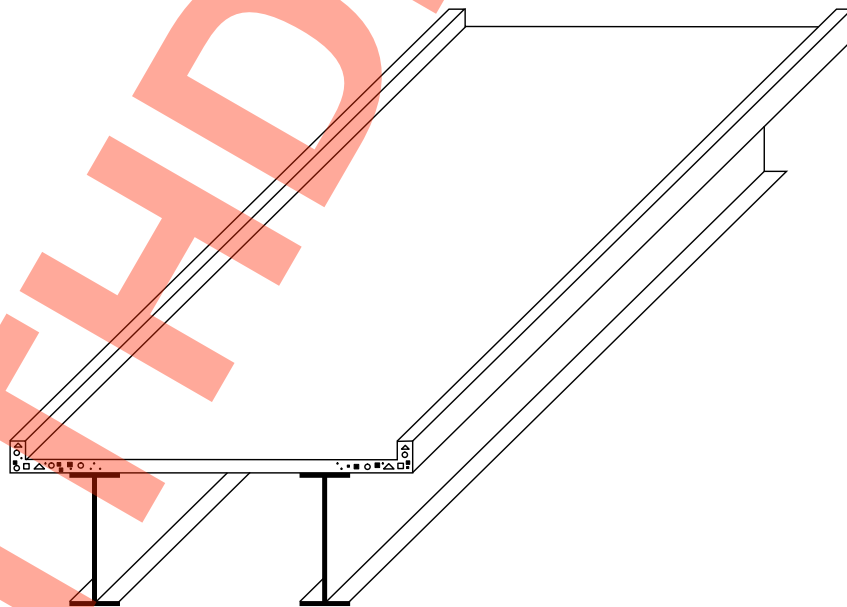

Figure 1 (b) Compression flange restrained by the deck

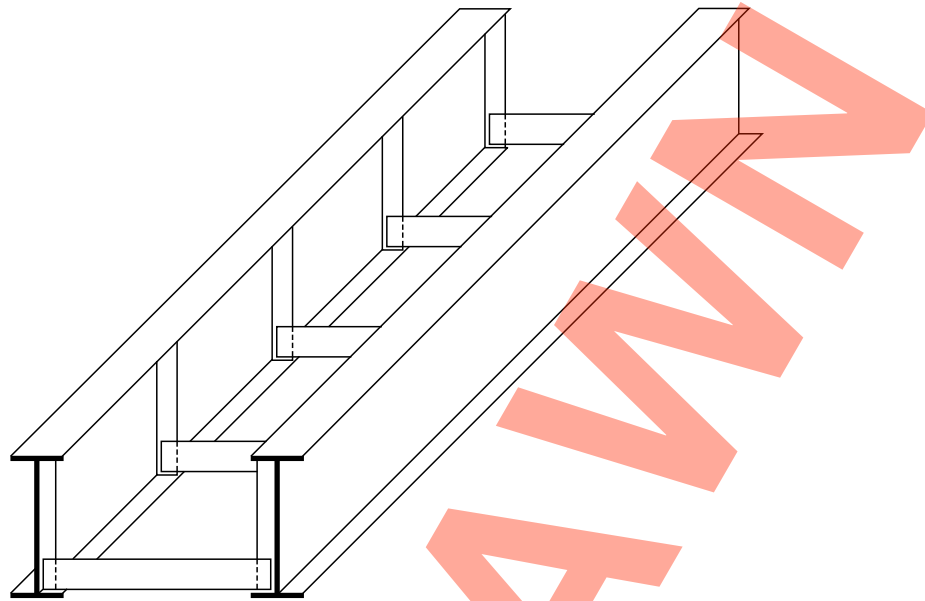

Figure 2 (a) Half through type bridge restrained by U-frame  
(deck or plan bracing not shown for clarity)

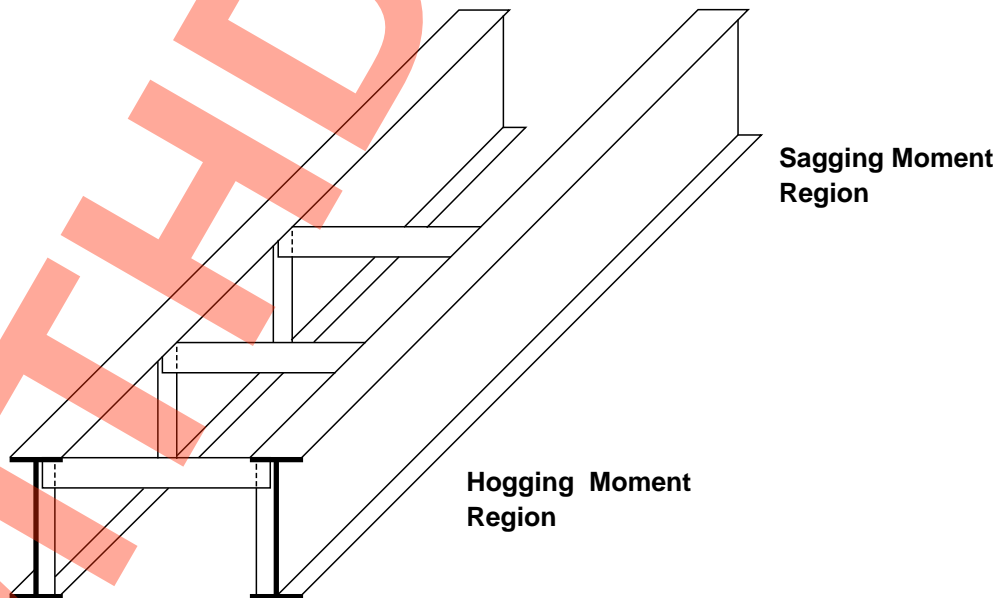

Figure 2 (b) Inverted U-frames at the hogging moment region of a deck type bridge  
(deck or plan bracing not shown for clarity)

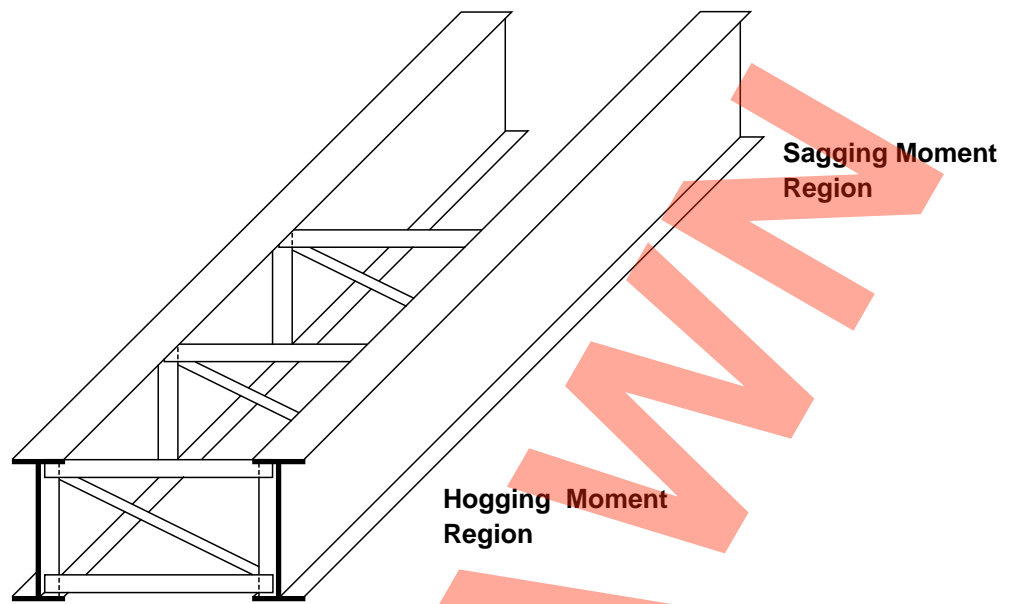

Figure 3 Stiff torsional bracing at the hogging moment region

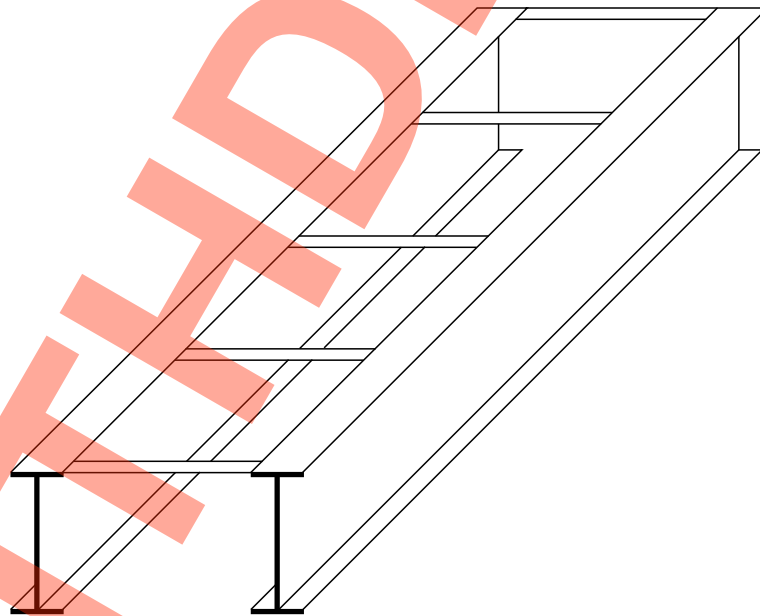

Figure 4 Ineffective bracing