
SERIES NG 500
DRAINAGE AND SERVICE DUCTS

Contents

Clause	Title	Page
NG 501	Pipes for Drainage and for Service Ducts	2
NG 502	Excavation for Pipes and Chambers	3
NG 503	Bedding, Laying and Surrounding of Pipes	3
NG 504	Jointing of Pipes	3
NG 505	Backfilling of Trenches and Filter Drains	3
NG 507	Chambers	4
NG 508	Gullies and Pipe Junctions	4
NG 509	Testing and Cleaning	4
NG 510	Surface Water Channels and Drainage Channel Blocks	5
NG 511	Land Drains	5
NG 512	Backfilling to Pipe Bays and Verges on Bridges	5
NG 513	Permeable Backing to Earth Retaining Structures	5
NG 514	Fin Drains	5
NG 515	Narrow Filter Drains	7
NG 516	Combined Drainage and Kerb Systems	7
NG 517	Linear Drainage Channel Systems	7
NG	Sample Appendices	A1

DRAINAGE AND SERVICE DUCTS

NG 501 Pipes for Drainage and for Service Ducts

1 Pipes can be made of materials that deflect relatively little under load before cracking (rigid pipes) or of materials that will tolerate large deflections under load before inward buckling occurs (flexible pipes). Flexible joints enable either type of pipe to take up differential settlement within the ground.

2 The Specification includes a wide range of pipe materials. The Contractor should normally be offered in Appendix 5/1 the full selection of alternative pipe and bedding combinations determined in accordance with Advice Note HA 40 as detailed in the HCD for pipes up to 900 mm diameter. The required pipe stiffness and impact resistance for plastics pipes should be specified in Appendix 5/1. The requirements will normally be:

- (i) ultimate pipe stiffness (STES) in excess of 1400 N/m² when tested in accordance with BS 4962 : 1989 ; and
- (ii) resistance to impact complying with BS 4962 : 1989 except that the striker used in the test shall have a mass of 1 kg and a 25 mm hemispherical radius.

Drains exceeding 900 mm diameter should be designed as structures and specified individually. A box culvert should not be specified where either a (concrete) box culvert or a (corrugated steel) piped culvert would be technically acceptable. Wherever possible, the Contractor should be offered a choice and the Overseeing Organisation should be consulted during the scheme preparation. Box culverts, piped culverts (and other drains) of clear span or internal diameter exceeding 900 mm are structures subject to Overseeing Organisation's technical approval. Care should be taken to ensure that there are no inconsistencies between any specific requirements included in an outline Approval in Principle form and the general requirements of the 500 Series. Where necessary, Contract-specific amendments should be included in Appendix 0/1 or 0/2 to achieve consistency.

Most of the pipes included in the Specification will normally be satisfactory from the hydraulic flow capacity factor. However some products, especially corrugated pipes, can vary from the norm (eg. clay/ concrete) and between manufacturers. The effect of a rougher pipe should be considered on the system as a

whole and not just on the length in question. A pipe which is not acceptable on a straight exchange basis may be acceptable if diameters on adjacent lengths are adjusted. Appendix 5/1 should provide the basis on which the Contractor is to submit his proposals for pipe types and makes.

3 Any tendency to attack by acidic ground water or sulfates present in the backfill or the ground should be taken into account when the use of concrete, asbestos cement, steel or iron pipes is being considered for inclusion in the schedule of acceptable alternatives in Appendix 5/1. When acid soils (pH less than 6.5) are encountered expert advice should be sought. There is some evidence that pipes made of sulfate-resisting cement and asbestos cement pipes will tolerate a pH as low as 6.0. The limiting value may be reduced to pH 5.5 when a bitumen coating is applied to the pipe. Sulfate attack on concrete is dealt with in Building Research Establishment Digest 363. Asbestos cement pipes will tolerate the same order of sulfates as concrete made from sulfate-resisting cement. More detailed information may be obtained from the manufacturers. Protection to the lower third of the inside of corrugated steel piped culverts by means of an asphalt or in situ concrete coating will be required where stones and rocks are likely to be carried by the flow. Iron pipes are treated with a pitch or bitumen coating and have high durability in most soils, but when acid conditions are known to be present the additional protection of a polyethylene sleeve is desirable. Clay, GRP, pitch fibre and UPVC pipes are resistant to a wide range of groundwater chemicals.

4 For corrugated steel pipes of lock seam fabrication with a diameter not exceeding 900 mm, specification of metal thickness should be given in Appendix 5/1. The tables issued by manufacturers recommend thicknesses corresponding to the diameter and depth of fill above the pipe.

5 Pipes of more than one type within any individual drain or service duct between consecutive chambers will be exceptional. Whatever the circumstance giving rise to the proposal, consideration should be given to whether the joint between the two pipes will provide an appropriately watertight joint and a smooth inner transition for rodding purposes.

6 Plastics pipes may deteriorate after a long period in sunlight. Where pipes have been manufactured and stored before being delivered to the Site, it may be

necessary for the Contractor to cover them until they are installed.

7 Any individual cable duct under a road may have to accept a power or a communication cable although these are normally placed in separate ducts. Certain pipe materials have been excluded from the Specification for use as ducts because cables cannot be readily drawn through them. Clauses NG 1421 and NG 1507 give further information on the use of ducts for electrical work. Ducts should be scheduled in a similar way to pipes in Appendix 5/2. Any special requirements of Statutory Undertakers etc. should be stated clearly.

NG 502 Excavation for Pipes and Chambers

1 In the preparation of Appendix 6/3, it may be considered appropriate to permit battering of slopes where this would not affect adversely the Permanent Works or the basis of structural design of the pipe/trench.

2 In the event of excavation to a greater depth than necessary the Contractor is obliged to reinstate. The use of mix ST1 concrete to remedy excess excavation should be restricted to areas where compaction is impracticable. Where the floor of the trench passes through a localised area of disturbed and uncompacted soil or softened clay further excavation and replacement with appropriate material may be required to allow pipe laying to proceed.

3 Where pipes are to be installed beneath heavily trafficked existing roads, etc, where it is undesirable that the existing ground surface should be disturbed, consideration should always be given to the possibility of inserting the pipe by suitable thrustboring or jacking processes.

NG 503 Bedding, Laying and Surrounding of Pipes

1 Pipe bedding material should be readily obtainable since a wide grading envelope is permitted including most gradings complying with BS 882. It needs to flow readily and compact uniformly, thus a low coefficient of uniformity is necessary. In order to make savings in coarser granular materials a sand bed may be adopted. Surround to pipes should be in bedding material or acceptable material (Class 8) as appropriate to the alternatives shown in the HCD.

2 A distinction is to be made between the requirements of bedding, haunching and surrounding and those of backfilling. The former comprise all operations of trench fill up to a level 300 mm above the top of the barrel of the pipe. Backfilling constitutes the

remaining operations up to ground level in verges and open ground and up to formation or sub-formation level under carriageways. Work above formation level constitutes construction or reinstatement of the pavement (see NG 706).

3 Concrete surround should be used exceptionally, eg. for protection of pipes against mechanical damage from subsequent operations after construction of the pipeline and where remedial measures due to over excavation are required. Protection of existing pipes where necessary may take the form of a concrete arch or slab above the pipe.

NG 504 Jointing of Pipes

1 Pipe joints for surface water drains, unlike foul drains, do not always have to be completely watertight. Small amounts of seepage as allowed in sub-Clause 509.7 can be tolerated particularly where pipes are laid in cuttings or below the water table. However, joints in pipes in soils that are predominantly fine sands or coarse silts should have watertight joints to prevent soil particles passing through the joint into the pipe leaving voids on the outside of the pipe. Where fine sands or coarse silts might be a problem but the more expensive rubber ring flexible joint is unwarranted, consideration can be given to certain proprietary wrap type joints that are available. These may also be specified where root penetration needs to be prevented. Requirements should be given in Appendix 5/1.

2 Most watertight joints will be flexible joints although rigid joints are occasionally used on clay pipes. In and under embankments, or if differential settlement is expected in compressible soils subject to non-uniform loading, then flexible joints and (except for pipes below the water table laid in non-erodible soils) watertight joints should be specified. The maximum length of pipe between flexible joints may have to be limited where considerable movement is expected. The limits of the exclusions should be shown in Appendix 5/1.

3 Culverts are generally considered to be drains but they do not necessarily require watertight joints. Where watertight joints are required for culverts this should be stated in Appendix 5/1.

NG 505 Backfilling of Trenches and Filter Drains

1 Type A material is intended for sub-soil drainage. The Specification allows a wide range of materials so that local sources may be used as far as possible. When soils to be drained require a particular grading of filter aggregate it can be specified under the heading Type C

in Table 5/5. The design should be based on knowledge of local sources of supply and Transport and Road Research Laboratory Report LR 346 which gives guidance on the design of filter materials. Type B material is intended for use where the drain is designed to intercept surface water flowing to the pipe. Grit from the carriageway may slowly block this type of filter and it may require cleaning or replacement periodically. Where filter drains are located close to carriageways and are likely to be overrun by traffic, methods of preventing the problem of "stone scatter" should be considered. Some possible solutions are shown on HCD Drawing Number B15.

2 Filter drains can be constructed by machines that excavate the trench, support the sides, lay the pipe and backfill with filter material in one operation. The trench is normally constructed with a semi-circular floor providing a most effective support to the pipe without further bedding. As contamination of the filter material is minimized by the supporting shutter attached to the machine a much narrower trench than that achieved by conventional excavation is possible.

NG 507 Chambers

1 Concrete chambers, precast or cast in situ against forms, do not require strengthening with additional concrete surround. Access shafts in precast concrete should be strengthened, however, as a protection against loads from backfilling operations. Brick chambers, including shafts do not need a concrete surround for strengthening. It may however be necessary to backfill with concrete where space is insufficient to permit compaction of one of the earthworks acceptable materials. Inspection chambers are those that can be maintained from the surface and do not need to be entered. The types of brick to be used for brick chambers, and beneath chamber frames, in normal circumstances are specified in Clause 2406. Where a different type of brick is required this should be described in Appendix 24/1. Any brickwork upon which chamber frames are seated shall be properly constructed.

2 Safety precautions require that chamber covers have a minimum opening of 600 mm diameter where personnel may be required to enter completely. In carriageways, hard shoulders and verges, chamber covers, frames and gratings should be Class D400. It will normally be expected that the minimum frame depth is 150 mm.

3 It may be necessary due to constraints in pipe lengths to vary the lengths of the articulated section described in sub-Clause 507.17. However the principle of having the joint nearest the chamber as close as

possible to the chamber and the next joint positioned so as to give an effective length of intervening articulated pipe, free from constraint by the trench bottom, should be maintained.

NG 508 Gullies and Pipe Junctions

1 Trapped gullies are essential only on connections to combined or foul drains in urban areas or on roads where traps are regularly and frequently emptied. In terms of pollution there is little difference in water quality between the flow through trapped or untrapped gullies although a trapped gully would normally retain the contents of a vehicle's sump in the event of an accident.

2 Where concrete trapped gullies are cast in situ using a permanent plastic mould, the part forming the trap should be equal in all respects to that of precast concrete or clay gullies.

3 Any brickwork upon which gully frames are seated should be properly constructed.

NG 509 Testing and Cleaning

1 Requirements for drain testing should be specified in Appendix 1/5. The air test does not indicate the location of any large leaks that may be present. A water test may follow the failure of an air test.

2 Fall of the test water level may be due to one or more of the following causes:

- (i) Absorption by pipes or joints.
- (ii) Excessive sweating of pipes or joints.
- (iii) Leakage from defective pipes or joints or plugs.
- (iv) Trapped air.

Some pipes absorb more water or trap more air at the joints than others. Allowance should be made for this by adding water to maintain the test head for appropriate periods. While the aim should be to commence the test period proper two hours after filling, the appropriate period may best be determined by conferring with the pipe manufacturers.

3 Closed circuit television (CCTV) inspection is a suitable alternative to the mandrel test and should always be used on foul sewers and connections to sewers. To avoid subsequent disputes it is essential to liaise with the drainage authority when checking connections to existing sewers to ensure acceptability of the work and to determine the extent of the survey required on existing sewers.

4 The test for partly watertight joints must be carried out before the pipe is laid because the water escaping from the joint has to be measured. The purpose of the test is to prove that the joint does not leak so excessively as to cause piping in any granular surround.

NG 510 Surface Water Channels and Drainage Channel Blocks

1 Requirements for these should be included in Appendix 5/3 and be compatible with the HCD.

NG 511 Land Drains

1 The Works are likely to disturb and render ineffective existing drainage systems in adjoining land; it will therefore be necessary for the Contractor to carry out without delay any such temporary or permanent remedial works as may be described in Appendix 5/1. The ideal arrangement for land drainage remedial works is that the system of drainage of land adjoining the road should be separate from the road drainage so that the reinstatement of the system is on the owner's land and the matter falls to be dealt with by the District Valuer as a matter of accommodation works. When such arrangements are not practicable or the cost is excessive, the existing land drainage system should be linked with the drainage system of the road.

NG 512 Backfilling to Pipe Bays and Verges on Bridges

1 Any special filling material, eg. lightweight material, should be described by providing additional information on the Drawings, cross-referenced in Appendix 5/1.

NG 513 Permeable Backing to Earth Retaining Structures

1 For granular backing, Type C has been added to allow for the design of a filter compatible with the particular type of filling to be employed adjacent to the structure. It is recognised that the use of Type A will not always meet the piping and permeability ratio criteria.

2 Fin drains are not allowed as permeable backing to structures because it is not yet possible to demonstrate that any of them will have the required design life of 120 years.

NG 514 Fin Drains

1 These consist of a core which will allow the free drainage of water entering through geotextile filters on the outside of the core. The core may consist of nets, webs, grids or preformed plastic sheets or strips. Some restrict entry through one side or confine water entering to part of the cross-sectional area of the core. Any such restrictions should be taken into account in assessing the flow characteristics of the drain. Fin drains are intended to be used for subsurface drainage, as shown in the HCD, to remove and keep out water from the road structure. They are provided to remove surface infiltration from the pavement layers, to prevent infiltration from shoulders, medians and verges into the pavement, and sometimes to cut off shallow groundwater seepage. They thus act as low-capacity filter drains. In normal circumstances, the Contractor should be permitted the choice of any of the types shown in the HCD. If however, for engineering reasons, exclusion of a particular type is required, this should be stated in Appendix 5/4. The minimum values for mechanical and hydraulic properties given in Clause 514 are intended for this particular usage and may not be relevant to fin drains used elsewhere. Additionally, the Clause requires specification of the pore size distribution of the geotextile and the inflow and discharge capacity of the fin drain determined for the site conditions.

2 The pore size for the geotextile should be selected using filtration criteria to be compatible with the adjacent soil or construction layer in order to prevent the occurrence of piping. The following soil retention criteria may be used in determining O_{90} . Other criteria are available.

Uniformity Coefficient of d_{60}/d_{10} Soil	Woven and Meltpbonded Geotextiles	Needle-punched Geotextiles
1 to 5	$O_{90}/d_{50} = 1$ to $O_{90}/d_{50} = 3$	$O_{90}/d_{50} = 4$ to $O_{90}/d_{50} = 6$
> 5	$O_{90}/d_{90} < 1$ or $O_{90}/d_{50} < 3$	$O_{90}/d_{90} < 1.8$ or $O_{90}/d_{50} < 6$

d_n = n% size in base soil (n% is finer)
 O_{90} = 90% opening (pore) size of geotextile (90% of openings are smaller)

In general it will be sufficient to specify only the maximum value of O_{90} that will satisfactorily retain the adjacent soil particles as the minimum O_{90} size will be governed by the permeability requirements in sub-Clause 4(v). Geotextiles will usually be in contact with variable surface soil deposits, as well as the more

uniform materials composing the pavement, and great accuracy in specification may not therefore be feasible. The finest O_{90} relevant to the various soil deposits likely to be encountered may be specified. An O_{90} value of 1 mm should be considered as the upper limit even with large grained soils. With cohesive fine grained soils such as clays the use of the above criteria will result in such small pore sizes that sufficient water flow cannot be obtained. In such cases the cohesion of the soil particles themselves is relied upon to prevent piping and a maximum O_{90} value of 250 microns may be chosen. Dispersive silts can present particular problems and in these cases the O_{90} value may be less than 250 microns: however, the value to be specified should be carefully considered in order both to avoid piping and to ensure sufficient long-term flow. The British Standard test to determine pore sizes (sub-Clause 4(iv)) is inappropriate for some geotextiles, such as needle-punched materials; if more than 20% of the glass beads are retained in the fabric. Pore sizes must then be obtained by other means such as wet sieving.

3 Sub-Clause 4(v) of Clause 514 requires the designer to specify the flow rate normal to the geotextile wrapping to the filter drain. The specified flow rate should incorporate a margin of safety to allow for the impeded flow due to the adjacent core of the fin drain (or the filter material in a narrow filter drain) as described in sub-Clause 13 of Clause 514. It should also incorporate a substantial margin to allow for the reduction of flow with time due to clogging. The long-term flow through a geotextile in contact with the coarse gravel may not differ significantly from the short-term flow measured in the standard test. In contrast, the long term flow through a geotextile in contact with a dispersive silt may be one thousand times smaller than the short-term flow. There is some evidence that chemical or biological leachates may also cause severe clogging.

Different rates of flow into the two sides of the fin drain may be specified, for example, if the water flows from the verges are expected to be very different to those from the pavement structure. A value of 10 litres/m²/sec is suggested for use against the granular sub-base and capping specified in the 800 Series. Very much smaller values are adequate for soils and backfills other than coarse gravels, and possibly dispersive silts or contaminated sites. It should be appreciated that, because of such long-term effects, these flow rates should not be used to determine the in-plane design requirements of the fin drain.

4 Sub-Clause 5 of Clause 514 requires specification of the in-plane flow capacity of the fin drain. This design capacity should allow for infiltration through the pavement and verges and any other source of ground

water ingress. Until more accurate means of establishing infiltration rates through the pavement are available a value not less than the mean intensity of a one year two hour rainfall should be assumed. The fin drain Type 5 of Drawing F18 in the HCD acts both as a filter drain and a carrier pipe. Thus in-plane flow must be specified for flow both along the drain parallel to the road edge and near-vertically down the drain. For all other drain types, only near-vertical downward flow need be specified. Fin drain Type 10 in Drawing F21 should either have an impermeable side or be covered by an impermeable membrane unless no significant blocking of the core will occur during the slip-forming of the channel.

Fin drains are normally laid at constant depth below the carriageway and their gradient will therefore follow that of the road. Drainage capacities should be designed for these gradients and outfall lengths determined accordingly. For drain Type 5 the flow rates that are stated in Appendix 5/4 should be the capacity required linearly extrapolated to the standard gradients in Table 5/8. Where fin drains utilise a pipe, capacities may be obtained from hydraulic tables and the required diameter specified.

5 Sub-Clause 9 of Clause 514 specifies the use of as-dug material for trench backfill. If this material when compacted is sufficiently less permeable to affect the efficiency of the drain, or contains stones larger than about 100 mm which could damage the drain, an alternative material compatible with the geotextile should be used.

6 Proper functioning of the fin drain and its ancillary components depends critically on adequate installation and joining procedures.

Fin drains can be problematical during construction phase for the following reasons.

- (i) They do not provide immediate drainage for the unpaved sub-base.
- (ii) They are not designed for surface water flows.
- (iii) Fine particles transported by surface water or vehicles may clog the filter or silt the drain.
- (iv) They may be damaged by the passage of construction traffic.

Appropriate protection measures must be taken, eg. polythene sheeting, temporary drainage channels, or warning fence. Alternatively, the drains may be installed towards the end of the construction phase.

7 All fin drains and their constituents must be the subject of a British Board of Agrément Roads and Bridges Certificate which certifies the values achieved

for the specified properties when tested in accordance with Clause 514. Fin drains are available in a variety of configurations with different types of core structure. In addition, several tests described in Clause 514 are modified British Standard tests or have been developed especially for the Specification and as yet there is little experience of their use. These two factors mean that some variation or interpretation of the test method may sometimes be necessary. The BBA will agree details of any appropriate variations in the specified test methods following consultation with the manufacturer. It is intended that whenever the Contractor proposes the use of any fin drain or constituent material he must supply copies of the appropriate BBA certificate to confirm that the material complies with the Contract requirements. (Further guidance may be sought from the Overseeing Organisation.)

NG 515 Narrow Filter Drains

1 Narrow filter drains are intended for use as edge of pavement sub-surface drains and are suitable alternatives to fin drains for this purpose. Both types have the same requirements of performance and the guidance given in NG 514 is equally applicable to determining the soil retention and permeability criteria of the geotextile used in narrow filter drains and to the discharge capacity of the drain. In normal circumstances, the Contractor should be permitted the choice of any of the types shown in the HCD. If however, for engineering reasons, exclusion of a particular type is required, this should be stated in Appendix 5/4.

2 In drain Type 8 the filtration function is achieved by a granular filter material and geotextile sock and in Type 9 by means of a geotextile wrapping to the drain. Both filters should be designed to be compatible with the adjacent soil or construction layer. For the Type 8 drain granular material the value of D₁₅ to be specified (Table 5/9) should be based on the criteria D_{15F} less than or equal to 5 x D_{85S} (TRRL Report LR346) where D_{85S} is the sieve size passing 85% by weight of the adjacent soil. The geotextile sock round the pipe is a second stage filter where it is required to retain the particles of the first stage granular material. However, the pipe when laid in the narrow trench may have insufficient granular surround for fully effective first stage filtration to be achieved. Pore sizes for the sock material should therefore be designed to also retain the finer soil particles outside the trench:

3 The specification for granular material in Table 5/9 is intended to permit the widest range of available material to be used. These limits have been set to reduce the risk of damage to the geotextile, to avoid gap grading of the filter material and to ensure an adequate

degree of permeability. For the material as specified a minimum value of permeability of about 1×10^{-4} m/second which is similar to that obtained by a clean coarse sand may be assumed. A higher permeability will rarely be necessary but if required it may be specified in Appendix 5/4.

4 Narrow filter drains require protection during the construction phase similar to that provided for fin drains (see NG 514.6).

5 The geotextiles used in narrow filter drains require British Board of Agrément Road and Bridges certification (see NG 514.7).

NG 516 Combined Drainage and Kerb Systems

1 The Drawings should show the location and gradient(s) of the combined drainage and kerb system, the position of access, silt trap, outfall and end units together with the position and invert level of the surface water outfall connection. The position of any movement joints required in the system, eg. at joints in bridge decks or concrete carriageways, should be shown. Details of any ducts, cabling, etc, required to pass under the kerb should be shown. The extent of the work to be designed by the Contractor should be clearly defined.

2 Combined drainage and kerb systems should be scheduled in Appendix 1/11 and cross-reference made to the design requirements given in Appendix 5/5.

NG 517 Linear Drainage Channel Systems

1 The linear drainage channels specified in Clause 517 may be used in trunk roads including motorways. Class D channels are designed to withstand loadings of all types of road vehicle that are permitted on trunk roads including motorways. Class C channels shall only be installed in locations which are protected from direct traffic loading, eg. in areas behind safety fencing. The range of slot dimensions permissible within Clause 517 is not compatible with safe usage by cyclists and pedestrians, and units with slot dimensions described in Clause 517 should not be used in areas subject to such traffic.

2 The Drawings should show the location of the linear drainage systems and the positions of the surface water outfall chambers into which the systems are to outfall. The position of any movement joints required in the system, eg. at joints in bridge decks or concrete carriageways, should be shown. Details of any ducts, cabling, etc required to pass under the systems should be shown. The extent of the work to be designed by the Contractor should be clearly defined.

- 3 Linear drainage channel systems should be scheduled in Appendix 1/11 and cross reference made to the design requirements given in Appendix 5/6.
- 4 Variations to stated dimensions may be considered providing that the product will meet the requirements of this specification.
- 5 A system comprising units which may be otherwise too small to accommodate design flows without surcharge may be acceptable in conjunction with the provision of additional intermediate or upstream chambers subject to the following requirements:
- a) Intermediate chambers should be compatible with the standards of the chambers shown on the Drawings and any longitudinal drains connecting such chambers should also be connected into the intermediate chambers.
 - b) Not more than one intermediate chamber should be permitted between the upstream and downstream chambers of any drain shown on the Drawings.
 - c) Not more than one additional chamber should be permitted upstream of each upstream chamber shown on the Drawings.

NG SAMPLE APPENDIX 5/1: DRAINAGE REQUIREMENTS

[Note to compiler: This should include:]

- (i) the basis of the hydraulic design of the system on which the Contractor shall submit his proposals for pipe types and makes [501.3];
- (ii) a schedule of permitted alternative pipe and bedding combinations; [which should be determined in accordance with Advice Note HA 40] [503.3] and list of pipelines to be constructed other than in a trench [608.8];
- (iii) requirements for box culverts [501.1];
- (iv) grading requirements for filter drain material Type C;
- (v) values of pipe stiffness and impact resistance for plastics pipes;
- (vi) plate thicknesses for bolted segmental plate pipes [501.4(i)] and minimum plate thickness for corrugated steel pipes of lock seam fabrication if different from sub-Clause 501.4;
- (vii) whether corrugated steel pipes are to have additional protection of hot-applied bitumen [501.5];
- (viii) where sulfate-resisting Portland cement is required for concrete pipes [Table 5/1];
- (ix) pipe classification to BS 5480 for GRP pipes for drainage [Table 5/1];
- (x) laying method for corrugated coilable perforated pipes [503.2]
- (xi) details of materials if differing from the requirements of sub-Clause 503.3(v);
- (xii) whether joints in surface water drains shall be watertight or partly watertight [504.2];
- (xiii) where rigid joints may be used [504.3]
- (xiv) backfilling requirements differing from sub-Clause 505.2; references to drawings giving locations where backfilling is required to a level other than that specified in sub-Clause 505.6;
- (xv) where saddles may be used [508.7 and 508NI.7]
- (xvi) material classification for backfilling filter drains and permeability requirements including test details [509.8];
- (xvii) references to drawings showing requirements for connecting existing drains to new drains and details of special connecting pipes [506.1];
requirements for sealing, removal or grouting of existing drains [506.3];
details of connecting existing land drains [511.1];
whether severed mole drains are to be intercepted by construction of a land drain [511.4];
requirements for backfilling mole channels if different from the requirements of sub-Clause 511.4;
- (xviii) references to drawings which show chamber types [507.1];
- (xvix) requirements for concrete to cast in situ chambers if differing from the requirements of sub-Clause 507.4;
- (xx) particular requirements for corrugated galvanized steel chambers [507.5];
- (xxi) requirements for testing chambers for foul drains for watertightness [507.8] and foul drain surveys by video camera [509.5];
- (xxii) details of chamber covers, gratings and frames [507.9] and details for special duty covers for use in carriageways [507.13]; requirements for minimum waterway area to gratings for catchpits [507.14];

- the classes and sizes of cast iron and steel gully gratings [508.4];
requirements for gully gratings if different from the requirements of sub-Clause 508.5;
- (xxiii) requirements for setting existing covers and gratings to level if different from the requirements of sub-Clauses 507.18 and 508.8;
- (xxiv) whether gullies are to be trapped or untrapped [508.1]; details of in situ concrete gullies [508.3];
- (xxv) references to drawings showing requirements for filling to pipe bays and verges if different from the requirements of sub-Clause 512.1;
- (xxvi) requirements for permeable backing if different from the requirements of sub-Clauses 513.1 and 513.2;
- (xxvii) requirements for the cleaning of chambers, gullies and drains [509.5].

NG SAMPLE APPENDIX 5/2: SERVICE DUCT REQUIREMENTS

[Note to compiler: This should include:]

- (i) details of duct construction [503.5]
[cross-reference should be made to HCD drawing no. I2 where appropriate];
- (ii) a schedule of service duct requirements *[similar to those in Appendix 5/1 for pipes];*
- (iii) details of permanent marker blocks and location posts required for service ducts [505.7]
[cross-reference should be made to HCD drawing no. II where appropriate].
- (iv) colour coding of ducts *[Refer to Health and Safety Executive booklet HS(G)47];*
- (v) references to drawings which show chamber types [501.8];

NG SAMPLE APPENDIX 5/3: SURFACE WATER CHANNELS AND DRAINAGE CHANNEL BLOCKS

[Note to compiler: State here specific requirements cross-referring to drawing numbers where appropriate, including HCD drawings listed in Appendix 0/4]

NG SAMPLE APPENDIX 5/4: FIN DRAINS AND NARROW FILTER DRAINS

[Note to compiler: This should include:]

1. Permitted alternative types of fin drain and narrow filter drain.
[Normally the choice of type of fin or narrow filter drain should be left to the Contractor.]
2. Drawing references showing locations.
3. The maximum permissible O_{90} determined from the pore size distribution curve of the geotextile *[514.4(iv) and 515.3]*.
4. The permeability of the geotextile *[514.4(v) and 515.3]*.
5. The long term in-plane flow for fin drains *[514.5]*.
6. Pipe diameters *[514.10 and 515.6]*.
7. Trench backfill material for fin drain if not as-dug material *[514.9]*.
8. D15 particle size for granular material in narrow filter drain Type 8 *[515.5]*.
9. Permeability of granular material in narrow filter drain where required *[515.5]*.
10. Maximum drain slope angle if different from 15° *[514.10 and 515.6]*.
11. Dimensions of fin drains and narrow filter drains if different from the requirements of sub-Clauses 514.10 and 515.6.
12. References to drawings and/or schedules which show required levels *[514.11 and 515.7]*.

NG SAMPLE APPENDIX 5/5: COMBINED DRAINAGE AND KERB SYSTEMS

[Note to compiler: Include here:]

1. Drawing references showing locations, etc.
2. Limiting dimensions:
 - (i) Maximum width and depth of units *[if applicable]*.
 - (ii) Kerb upstand.
 - (iii) Kerb profile *[if applicable]*.
3. Strength requirements
[units should normally be capable of bearing a wheel load of 11.5 tonnes].
4. Hydraulic design parameters
[roughness coefficients should not be specified].
5. Class of concrete or mortar bedding/surround.

NG SAMPLE APPENDIX 5/6: LINEAR DRAINAGE CHANNEL SYSTEMS

[Note to compiler: Include here:]

1. Drawing references showing locations, etc.
2. Limiting dimensions:
 - i) Maximum width and depth of units [517.4 and 517.18].
 - ii) Dimensions of side-entry inlets of units to be used in or adjacent to porous asphalt [517.7].
3. Hydraulic design parameters [517.1 and 517.3].
[roughness coefficients should not be specified].
4. Class of concrete bedding/surround.
5. Any special fittings required [517.9].
6. Dimensions of test blocks [Table 1 following].

Table 1: Dimensions of Test Blocks

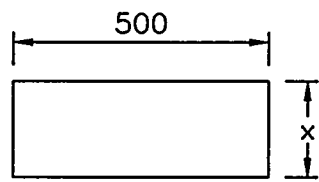
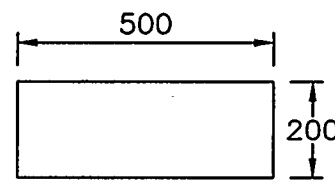
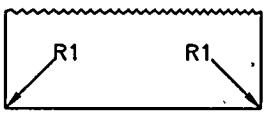
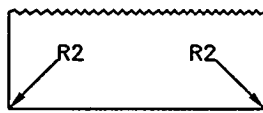
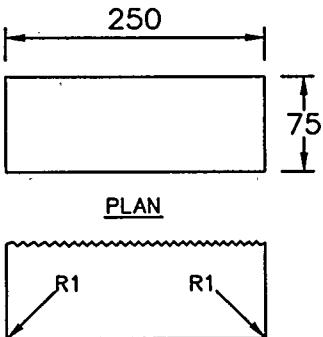
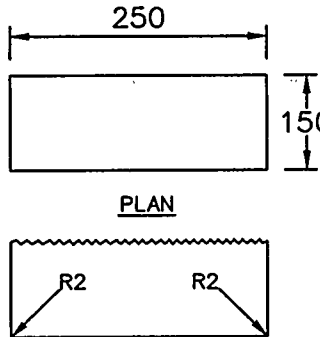
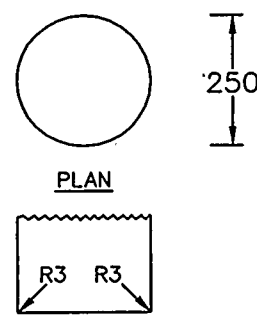
For testing channel units of dimensions as shown in Figures 1 and 2 following	
$b \leq 200\text{mm}$	$b > 200\text{mm}$
 <p>500</p> <p>x</p> <p>PLAN</p>	 <p>500</p> <p>200</p> <p>PLAN</p>
 <p>R1 R1</p> <p>ELEVATION</p> <p>$R1 \leq 3\text{mm}$</p>	 <p>R2 R2</p> <p>ELEVATION</p> <p>$R2 \leq 3\text{mm}$</p>

Table 1: Dimensions of Test Blocks (continued)

For testing gratings and covers of channel units of dimensions as shown in Figures 1 and 2		
$b < 200\text{mm}$	$200\text{mm} \leq b \leq 300\text{mm}$	$b > 300\text{mm}$
 <p>PLAN</p> <p>ELEVATION</p> <p>$R1 \leq 3\text{mm}$</p>	 <p>PLAN</p> <p>ELEVATION</p> <p>$R2 \leq 3\text{mm}$</p>	 <p>PLAN</p> <p>ELEVATION</p> <p>$R3 \leq 3\text{mm}$</p>

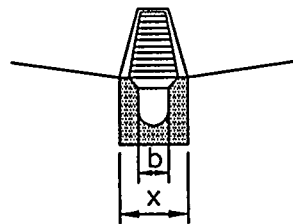


Figure 1 (example)
System with grating

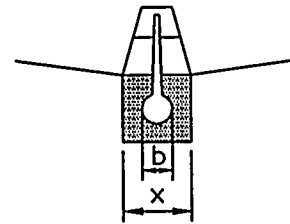


Figure 2 (example)
System with closed profile and
continuous or intermittent inlet slot
on top

Note

Fig.1 indicates a typical non-integral grating system. Dimensions apply similarly to integral grating system.