

Type 1A (Flexible carriageway).

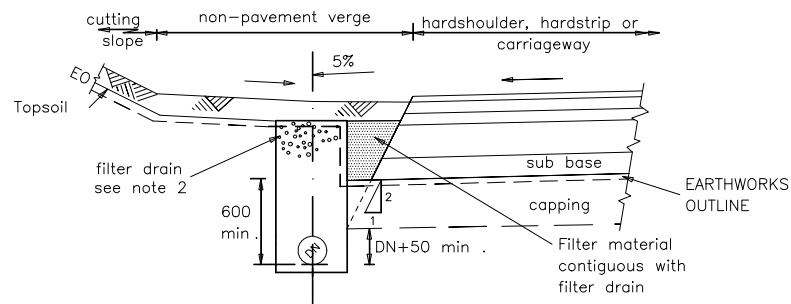

Type 1C (Flexible composite carriageway).

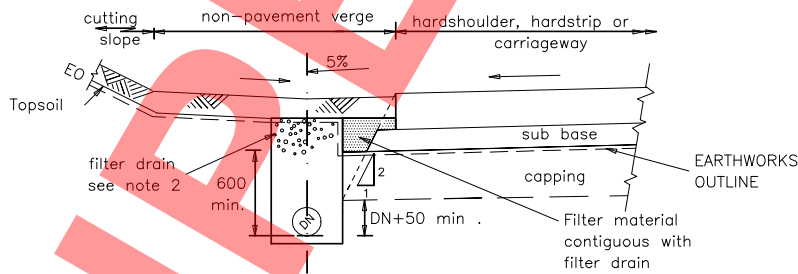

Type 1B (Rigid carriageway).

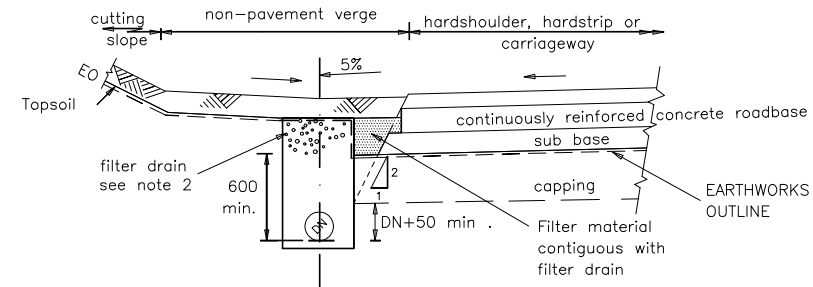

Type 1D (Rigid composite carriageway).

NOTES

1. ALL DIMENSIONS ARE IN MILLIMETRES.
2. Alternative treatments to top of filter drains are shown on Drawing No. B15. Type V is shown on this Drawing.
3. 'DN' represents nominal diameter of the pipe.
4. Pipes shall be laid to the levels shown on the Drawings and schedules.

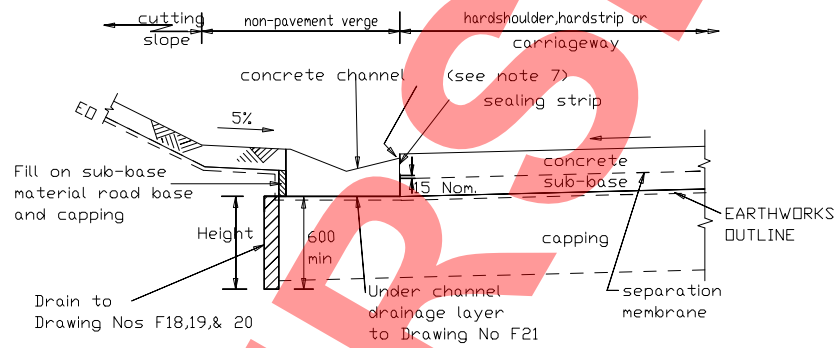

TYPE 2A  
(Channel formed on capping or formation layer)

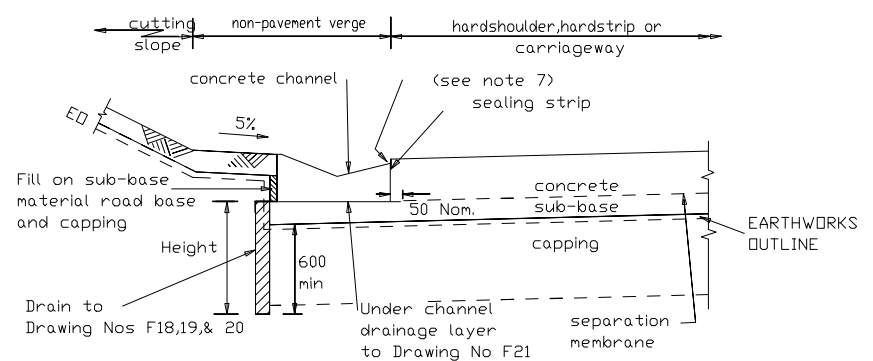

TYPE 2C  
(Channel formed on sub-base layer)

NOTES

1. ALL DIMENSIONS ARE IN MILLIMETRES. These details also apply to rigid composite carriageway with any necessary modifications.
2. For details of concrete channel see Drawing No B14.
3. The sealing strip and the vertical part of under channel drainage layer shown for when channel is cast before pavement. They shall be fixed to pavement edge when pavement cast before channel.
4. Sealing strip to be to Clause 1014 of S.H.W.
5. For details of under-channel drainage layer see Drawing No F21.
6. Channels may be freestanding or cast in one with the pavement. In the latter case the requirements of NOTES 3 & 4 may be ignored. Transverse joints in carriageway slabs shall be continued through channel sections cast in one with the slab.
7. Notwithstanding other tolerances in the Specification, the finished level of the channel shall not be higher nor more than 10mm lower than the finished level of the edge of the adjacent carriageway.

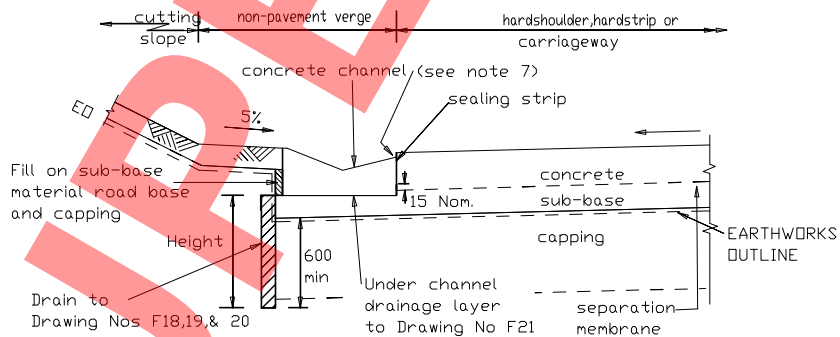

TYPE 2B  
(Channel base formed within sub-base layer)

HIGHWAY CONSTRUCTION DETAILS

EDGE OF PAVEMENT  
DETAILS

|       |        |
|-------|--------|
| B     | AUG 93 |
| A     | DEC 91 |
| Issue | Date   |

CUTTINGS - SURFACE  
WATER CHANNEL FOR RIGID  
CARRIAGEWAY

Drawing No.

B2

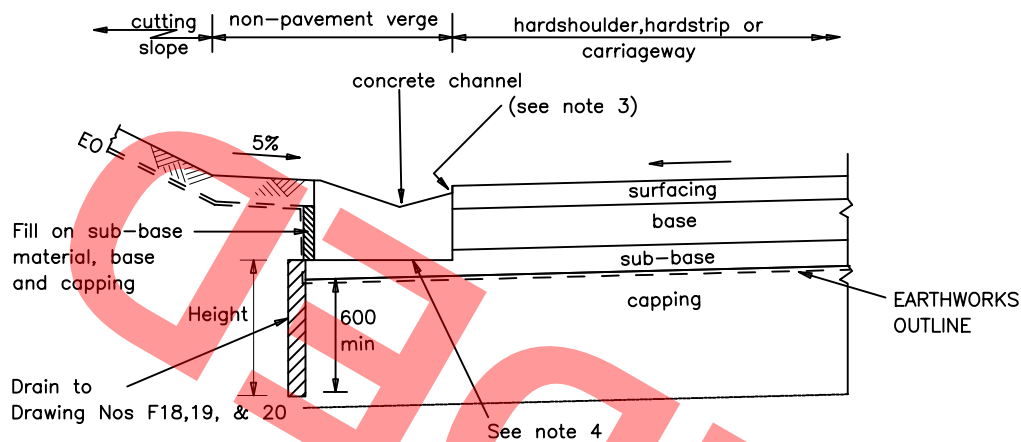

TYPE 3A  
(Channel base formed within sub-base layer)

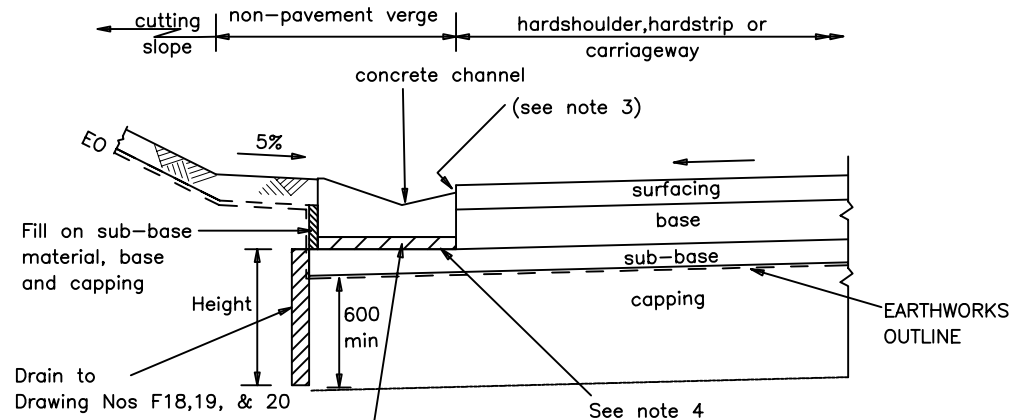

TYPE 3C  
(Channel base formed on first base layer)

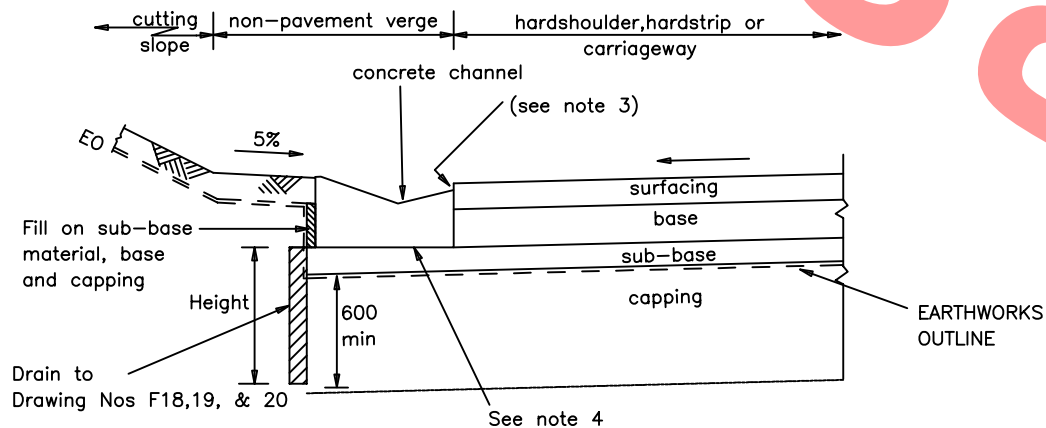

TYPE 3B  
(Channel base formed on the sub-base layer)

NOTES

1. ALL DIMENSIONS ARE IN MILLIMETRES. These details also apply to flexible composite carriageway with any necessary modifications.
2. For details of concrete channel see Drawing No B14.
3. Notwithstanding other tolerances in the Specification the finished level of the channel shall not be higher nor more than 10mm lower than the finished level of the adjacent carriageway.
4. Where used in conjunction with thin surfacing the under drainage detail shown in F21 shall apply in full.

|       |        |
|-------|--------|
| C     | MAY 02 |
| B     | AUG 93 |
| A     | DEC 91 |
| Issue | Date   |

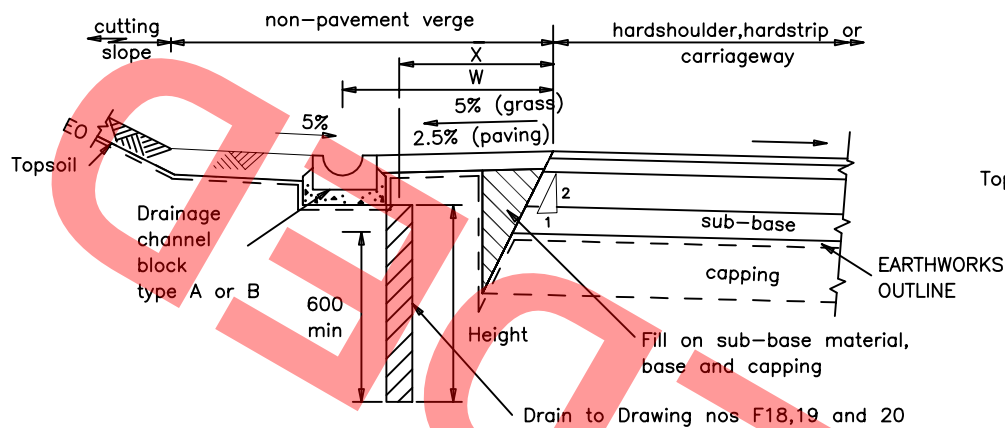

Type 4A (Flexible carriageway).

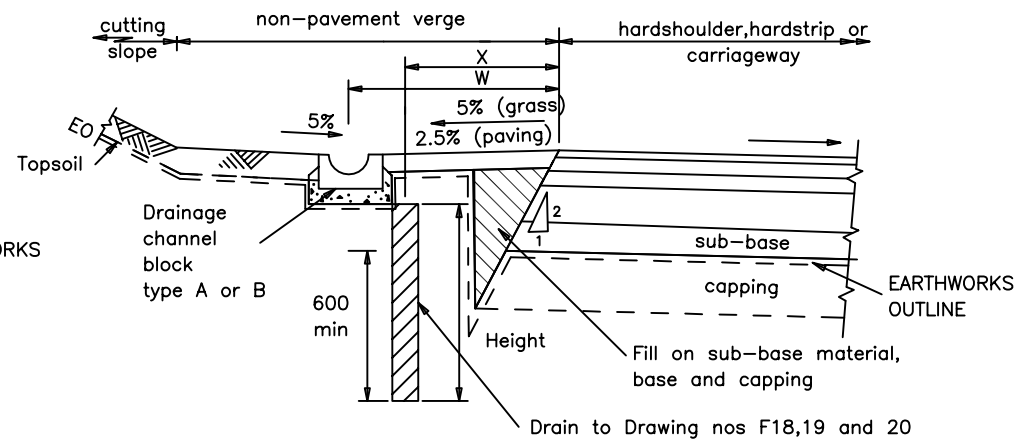

Type 4C (Flexible composite carriageway).

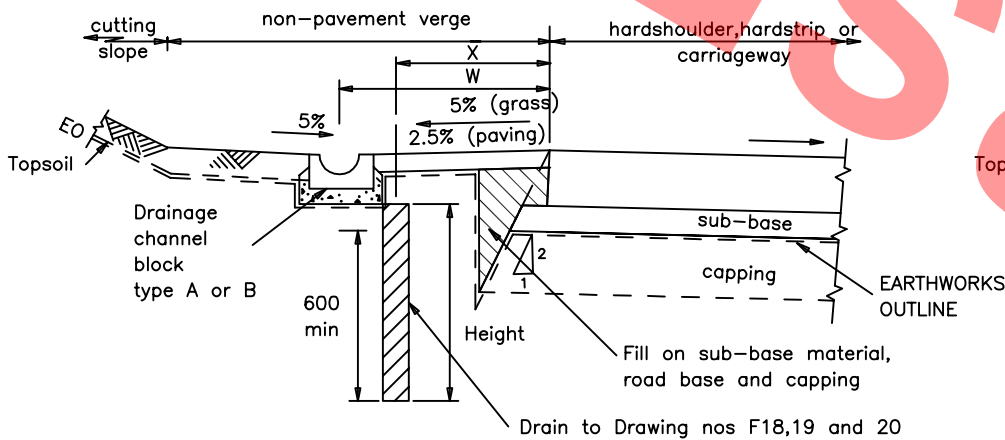

Type 4B (Rigid carriageway).

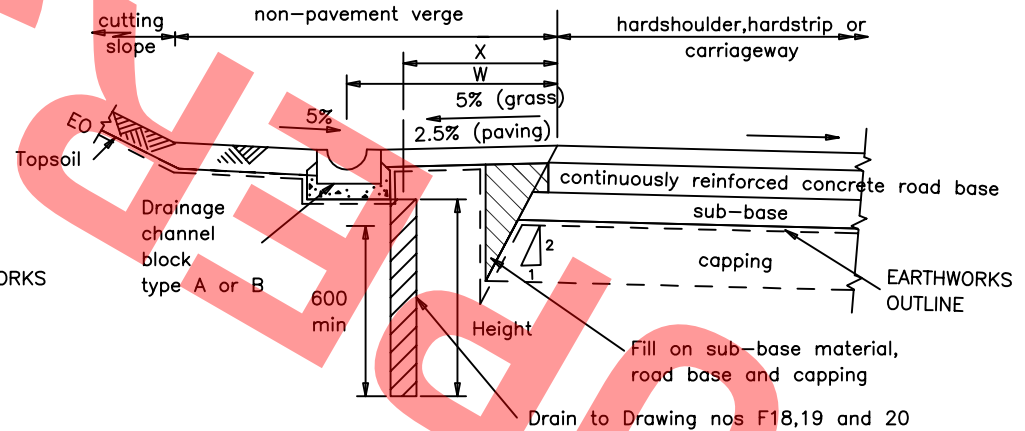

Type 4D (Rigid composite carriageway).

NOTES

1. ALL DIMENSIONS ARE IN MILLIMETRES.
2. Dimensions X & W to be as described in Appendix 5/3.
3. Topsoil or paving in verges shall be as described in Appendix 5/3.
4. For details of channel blocks A and B see Drawing No. F15.

|       |        |
|-------|--------|
| B     | MAY 02 |
| A     | DEC 91 |
| Issue | Date   |

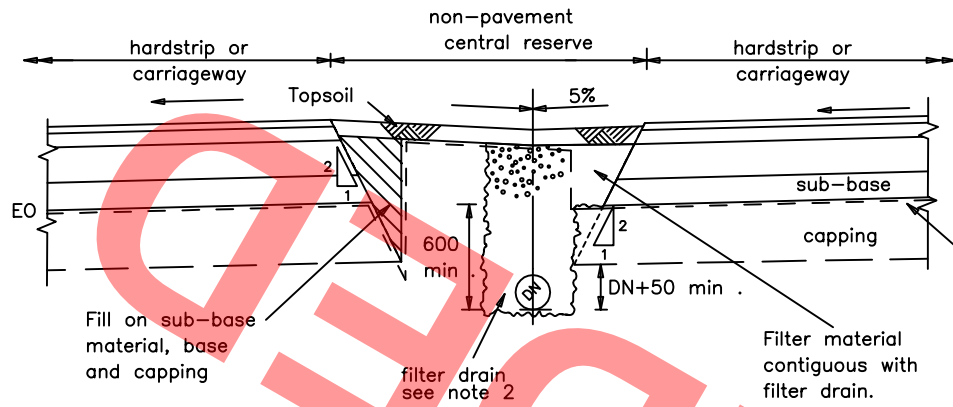

TYPE 11A (Flexible carriageway).

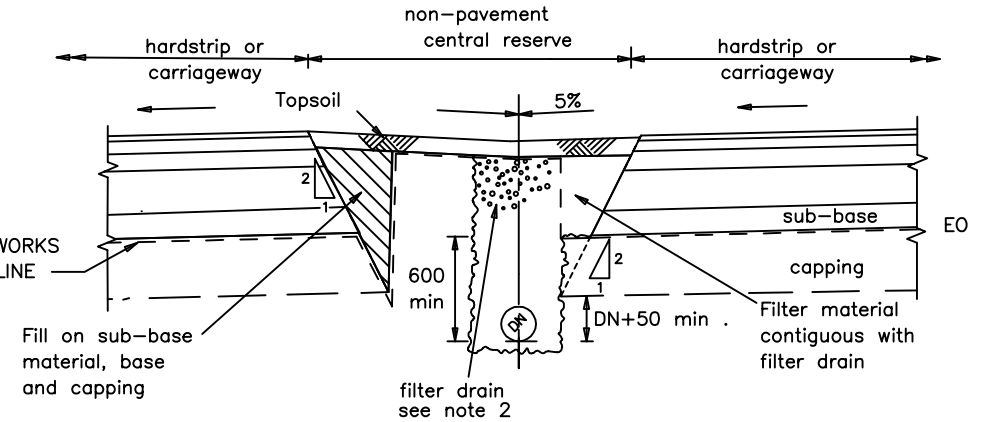

TYPE 11C (Flexible composite carriageway).

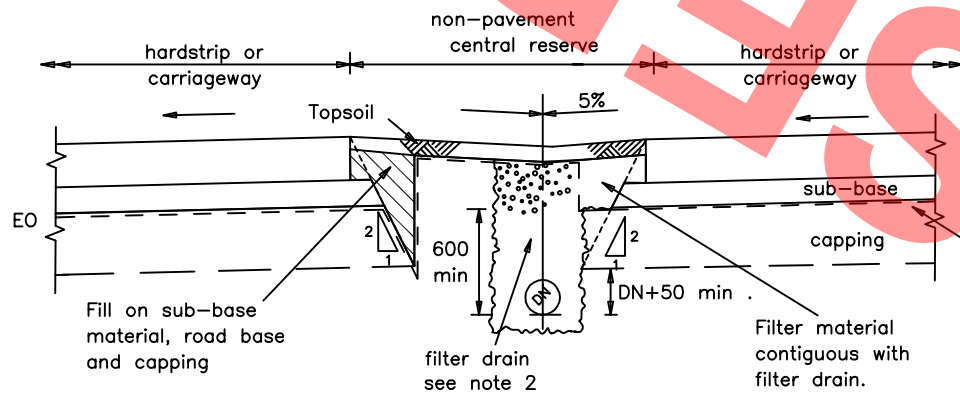

TYPE 11B (Rigid carriageway).

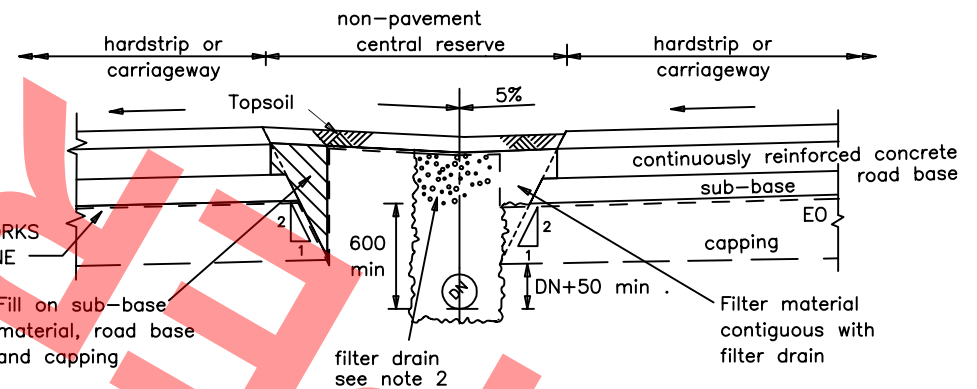

TYPE 11D (Rigid composite carriageway).

NOTES

1. ALL DIMENSIONS ARE IN MILLIMETRES.
2. Alternative treatments to top of filter drains are shown on Drawing No. B15. Type V drain is shown on this Drawing.
3. 'DN' represents nominal diameter of pipe.
4. Pipes shall be laid to the levels shown on the Drawings and schedules.

|       |        |
|-------|--------|
| B     | MAY 02 |
| A     | DEC 91 |
| Issue | Date   |



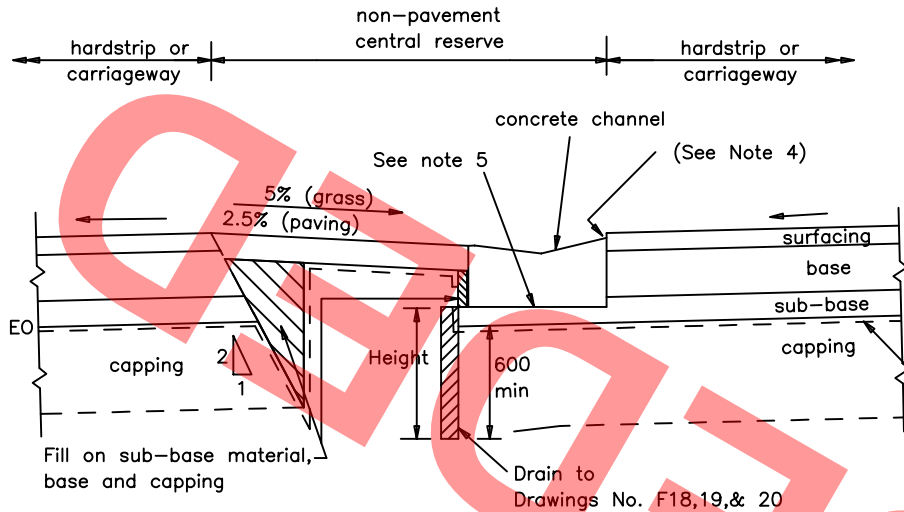

TYPE 13A  
(Channel base formed within sub-base layer)

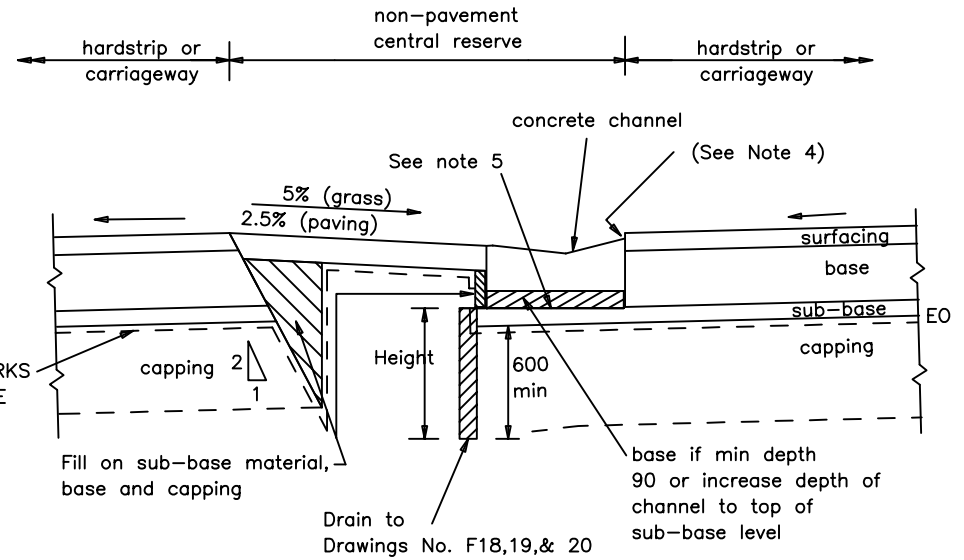

TYPE 13C  
(Channel formed on first base layer)

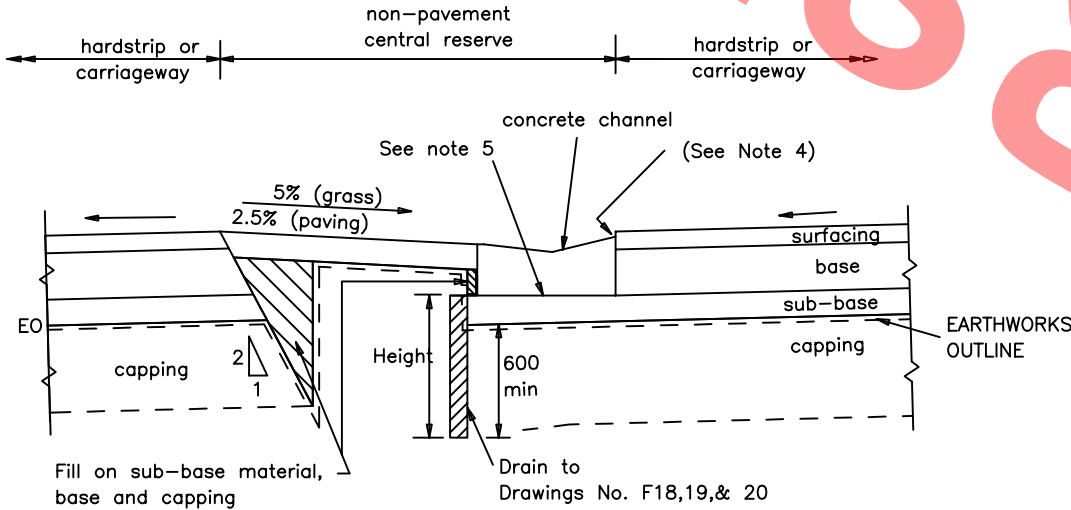

TYPE 13B  
(Channel formed on sub-base layer)

NOTES

1. ALL DIMENSIONS ARE IN MILLIMETRES  
These details also apply to flexible composite carriageway with any necessary modifications.
2. For details of concrete channel see Drawing No B14.
3. Topsoil or paving in the central reserve shall be as described in Appendix 5/3
4. Notwithstanding other tolerances in the Specification the finished level of the channel shall not be higher nor more than 10mm lower than the finished level of the adjacent carriageway.
5. Where used in conjunction with a thin surfacing the under drainage detail shown in F21 shall apply in full.

|       |        |
|-------|--------|
| C     | MAY 02 |
| B     | AUG 93 |
| A     | DEC 91 |
| Issue | Date   |

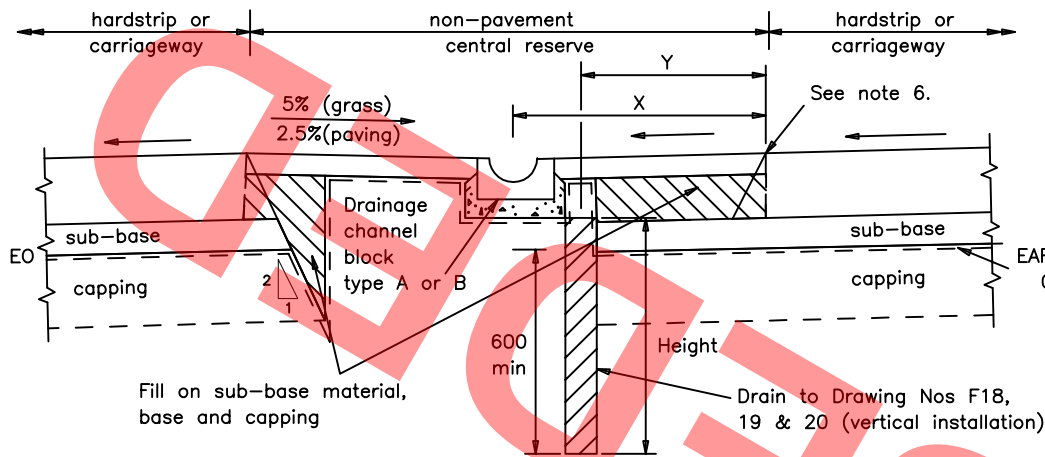

TYPE 14  
(Drainage Channel Block & Drain)

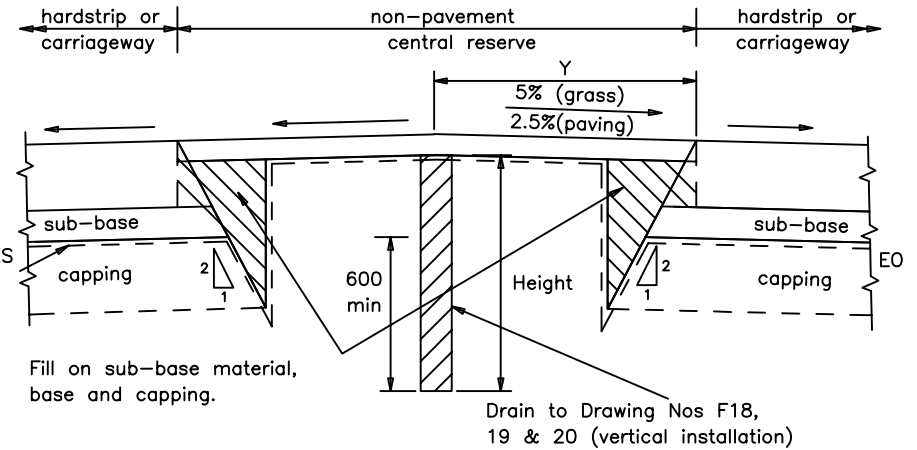

TYPE 16  
(Drain in Raised Central Reserve)

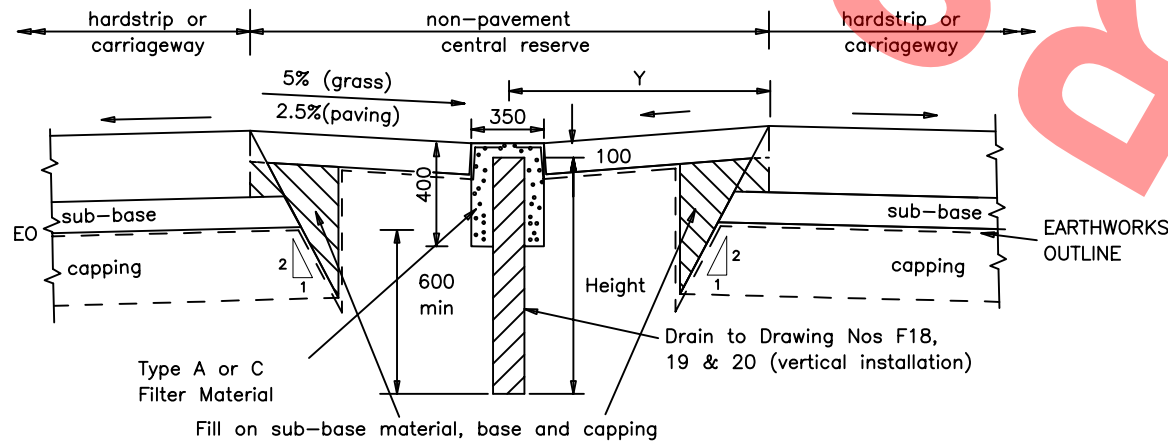

TYPE 15  
(Drain in Dished Central Reserve)

NOTES

1. ALL DIMENSIONS ARE IN MILLIMETRES.
2. Dimensions X & Y to be as described in Appendix 5/3.
3. For details of drainage channel blocks see Drawing No. F15.
4. Flexible carriageway construction is shown. Variations for other constructions to be as shown on Drawing No B1.
5. Topsoil or paving in the central reserve shall be as described in Appendix 5/3.
6. Where the central reserve is grassed and carriageway surface water is to flow over the edge the surface of the central reserve should be set 40mm below adjacent hardstrip or carriageway.

|       |        |
|-------|--------|
| B     | MAY 02 |
| A     | DEC 91 |
| Issue | Date   |

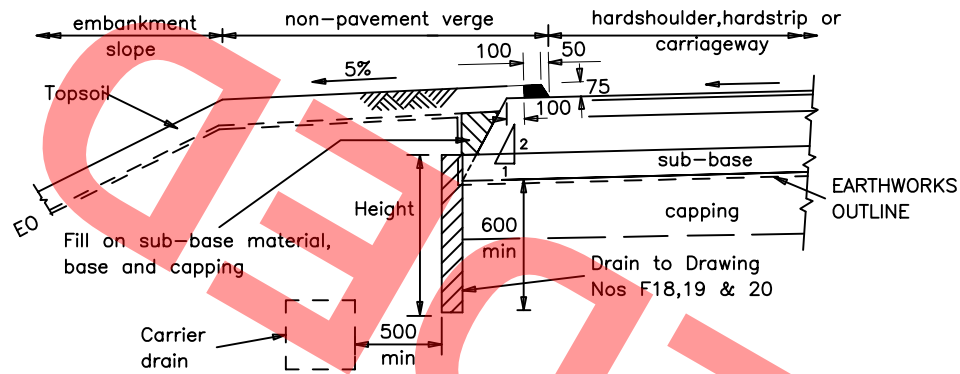

Type 21A (Flexible carriageway).

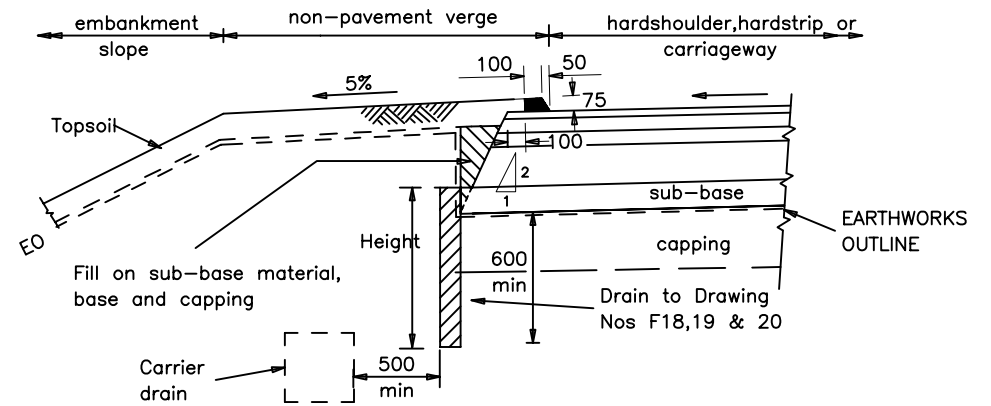

Type 21C (Flexible composite carriageway).

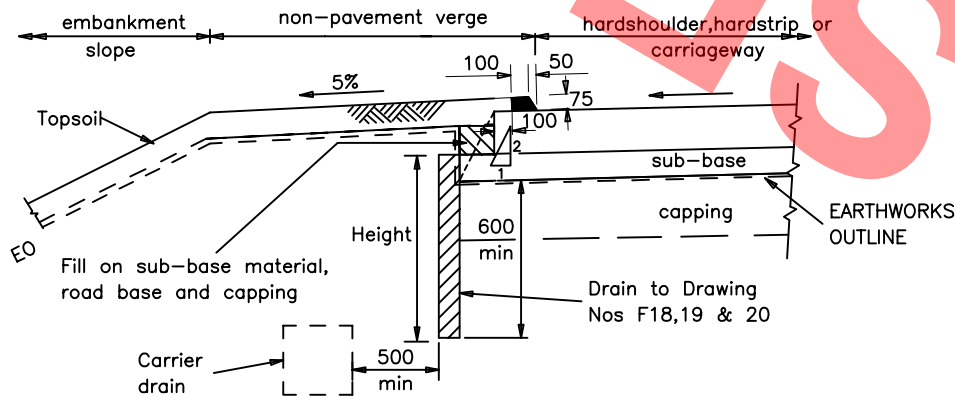

Type 21B (Rigid carriageway).

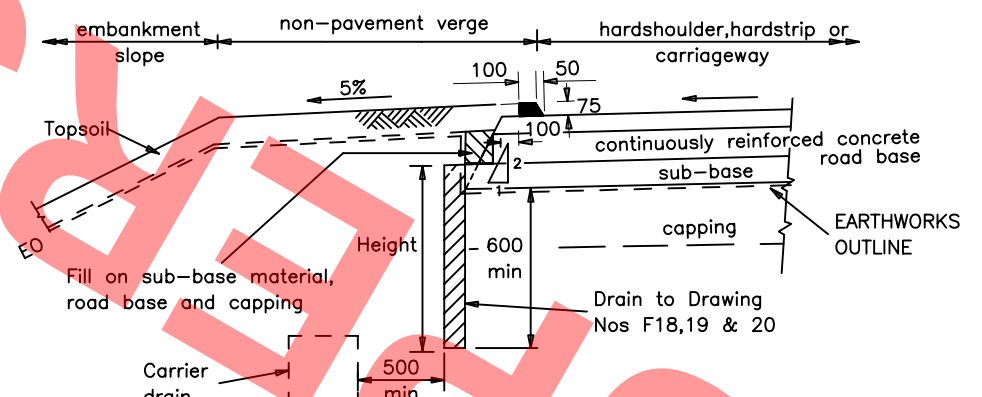

Type 21D (Rigid composite carriageway).

NOTES

1. ALL DIMENSIONS ARE IN MILLIMETRES.
2. Carrier drains shall be as detailed on the Drawings and schedules.

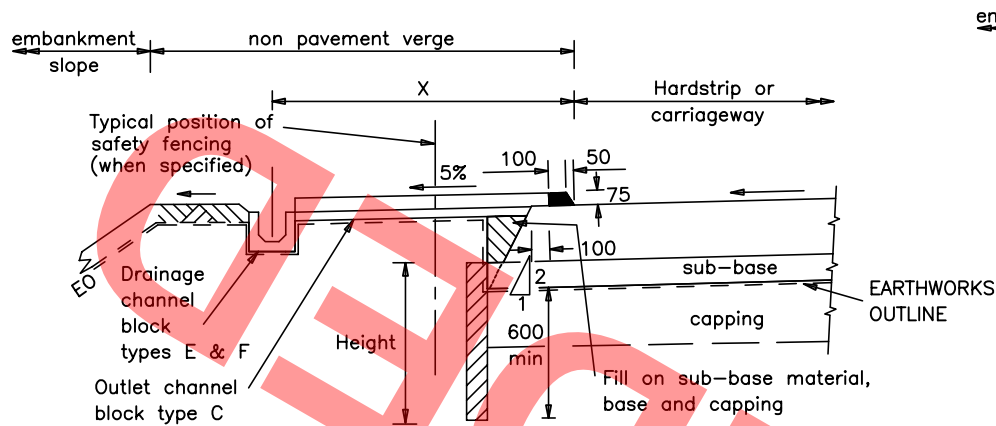

Type 21E (Flexible carriageway).

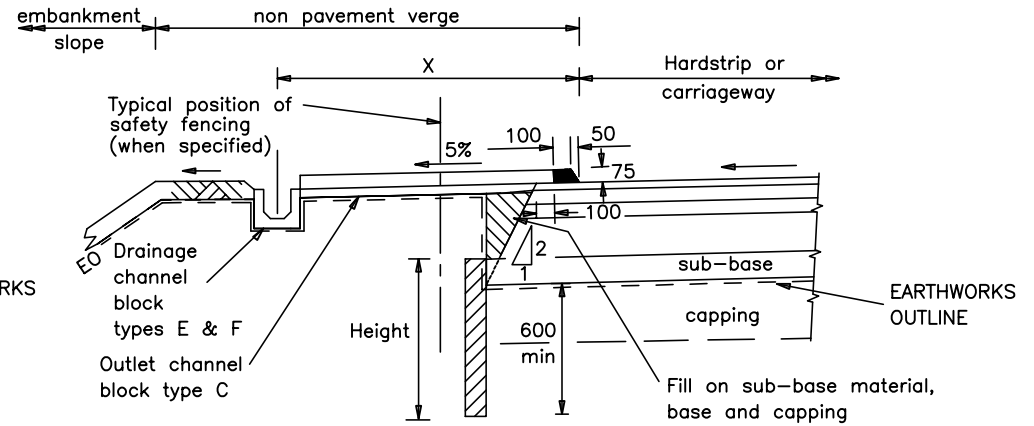

Type 21G (Flexible composite carriageway).

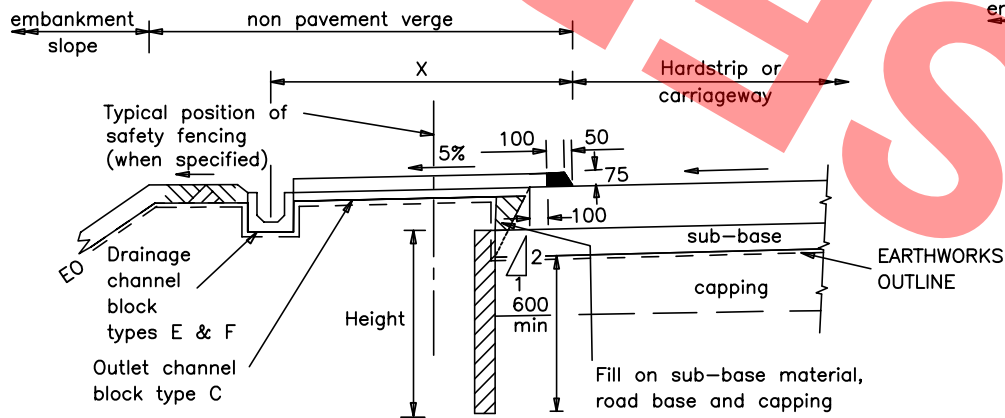

Type 21F (Rigid carriageway).

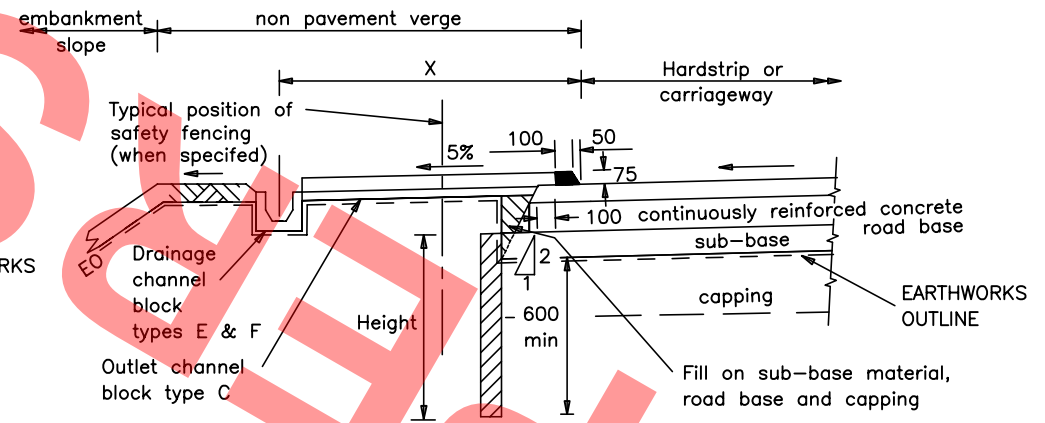

Type 21H (Rigid composite carriageway).

NOTES

1. ALL DIMENSIONS ARE IN MILLIMETRES.
2. Drains shall comply with Drawing Nos F18,19,20.
3. For details of drainage channel blocks see Drawing Nos F15 & F16.
4. Dimension X shall be as described in Appendix 5/3.
5. Not applicable on motorways.

|       |        |
|-------|--------|
| C     | MAY 02 |
| B     | MAR 98 |
| A     | DEC 91 |
| Issue | Date   |

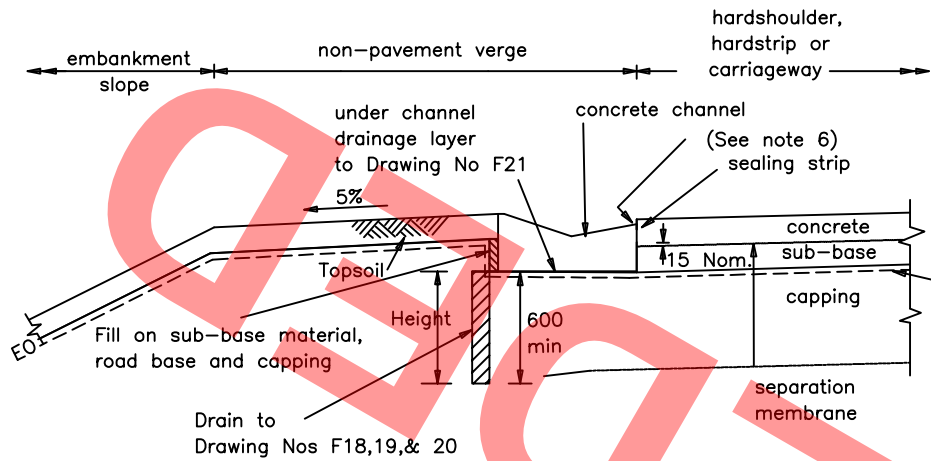

TYPE 22A

(Channel formed on capping or formation layer)

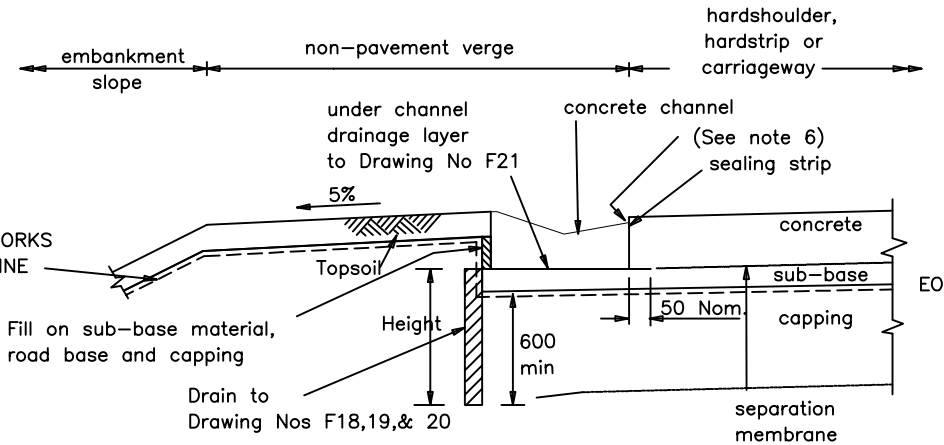

TYPE 22C

(Channel formed on sub-base layer)

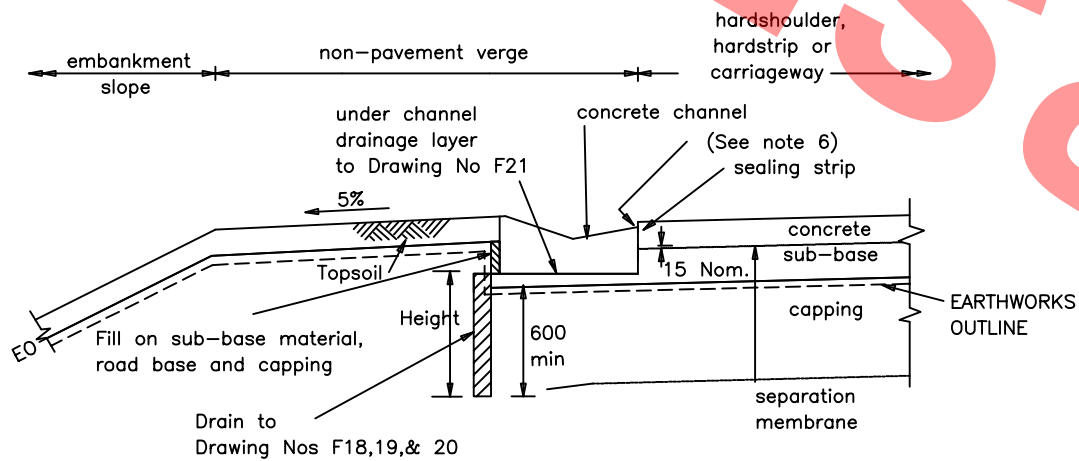

TYPE 22B

(Channel base formed within sub-base layer)

NOTES

1. ALL DIMENSIONS ARE IN MILLIMETRES. These details also apply to rigid composite carriageway with any necessary modifications.
2. For details of concrete channel see Drawing No. B14.
3. The sealing strip and the vertical part of under channel drainage layer shown for when channel is cast before pavement. They shall be fixed to pavement edge when pavement cast before channel.
4. Sealing strip to be to Clause 1014 of S.H.W.
5. Where used in conjunction with a thin surfacing the under drainage detail shown in F21 shall apply in full.
6. Notwithstanding other tolerances in the Specification, the finished level of the channel shall not be higher nor more than 10mm lower than the finished level of the edge of the adjacent carriageway.
7. Channel may be freestanding or cast in one with the pavement. In the latter case the requirements of NOTES 3 & 4 may be ignored. Transverse joints in carriageway slabs shall be continued through channel sections cast in one with the slab.

HIGHWAY CONSTRUCTION DETAILS

EDGE OF PAVEMENT  
DETAILS

|       |        |
|-------|--------|
| C     | MAY 02 |
| B     | AUG 93 |
| A     | DEC 91 |
| Issue | Date   |

EMBANKMENTS –  
SURFACE WATER CHANNEL  
FOR RIGID CARRIAGEWAY

Drawing No.

B11

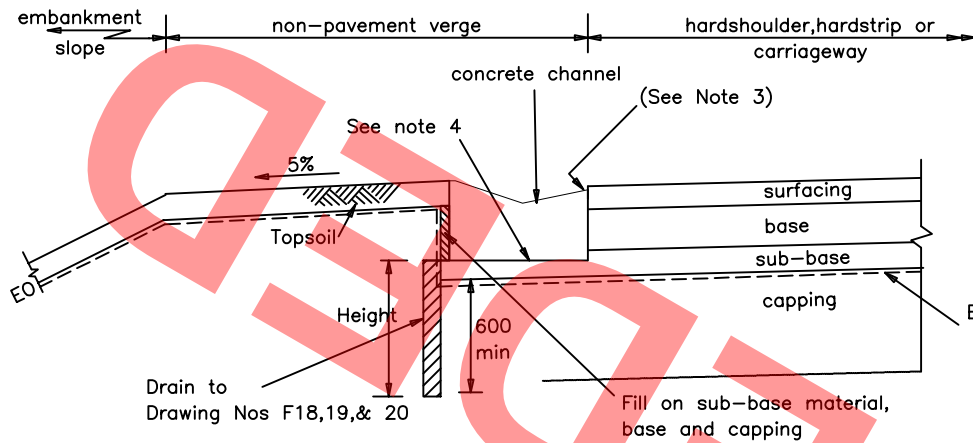

TYPE 23A  
(Channel base formed within sub-base layer)

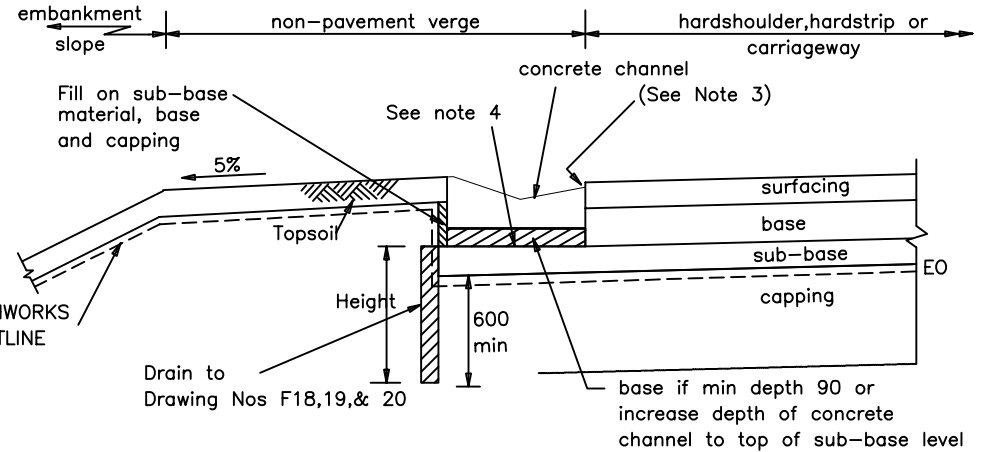

TYPE 23C  
(Channel formed on first base layer)

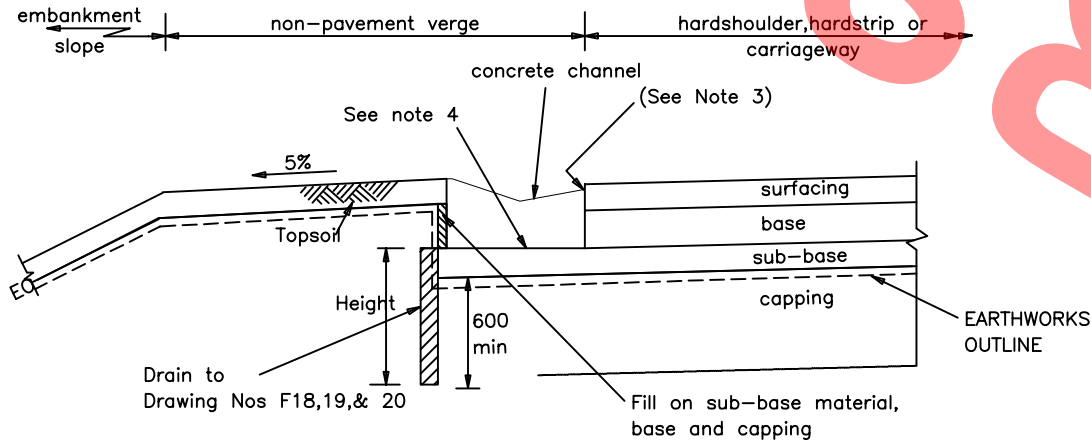

TYPE 23B  
(Channel formed on the sub-base layer)

NOTES

1. ALL DIMENSIONS ARE IN MILLIMETRES. These details also apply to flexible composite carriageway with any necessary modifications.
2. For details of concrete channel see Drawing No.B14.
3. Notwithstanding other tolerances in the Specification the finished level of the channel shall not be higher nor more than 10mm lower than the finished level of the edge of the adjacent carriageway.
4. Where used in conjunction with a thin surfacing the under drainage detail shown in F21 shall apply in full.

|       |        |
|-------|--------|
| D     | MAY 02 |
| C     | MAR 98 |
| B     | AUG 93 |
| A     | DEC 91 |
| Issue | Date   |

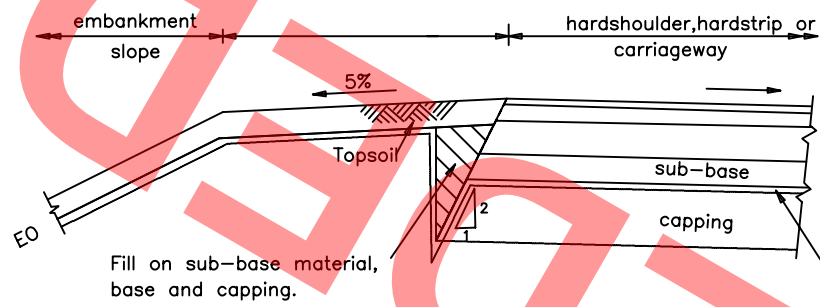

Type 24A (Flexible carriageway).

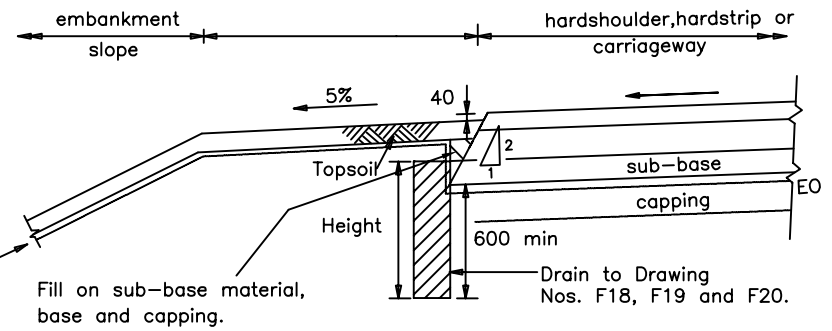

Type 24C (Flexible composite carriageway).

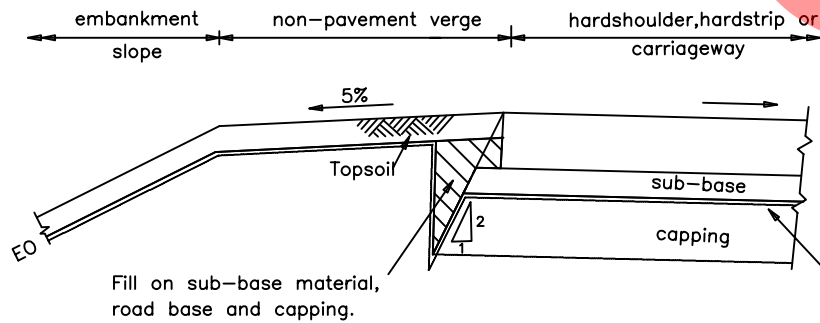

Type 24B (Rigid carriageway).

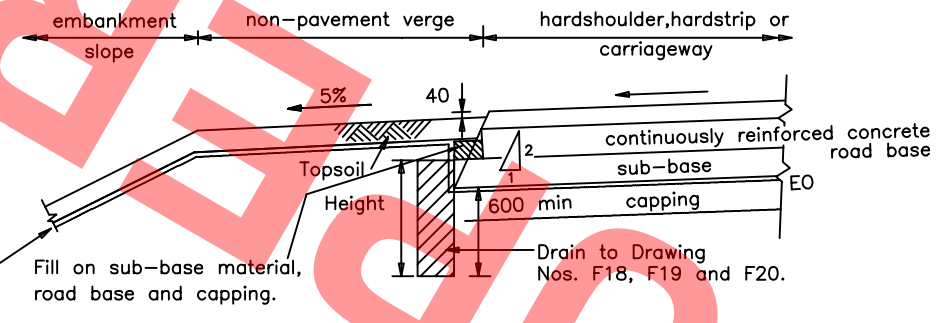

Type 24D (Rigid composite carriageway).

NOTES.

1. ALL DIMENSIONS ARE IN MILLIMETRES.

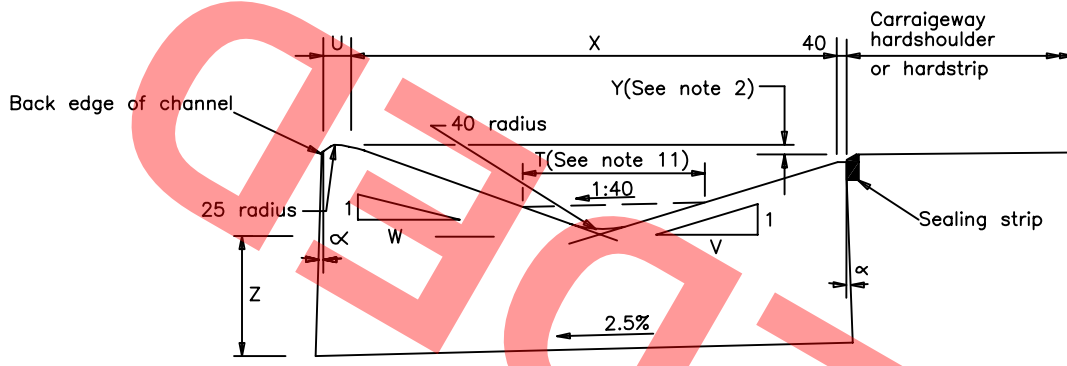

**Type A**  
 (Channel cast before or after pavement construction)  
 (Drawn to suit verge location)

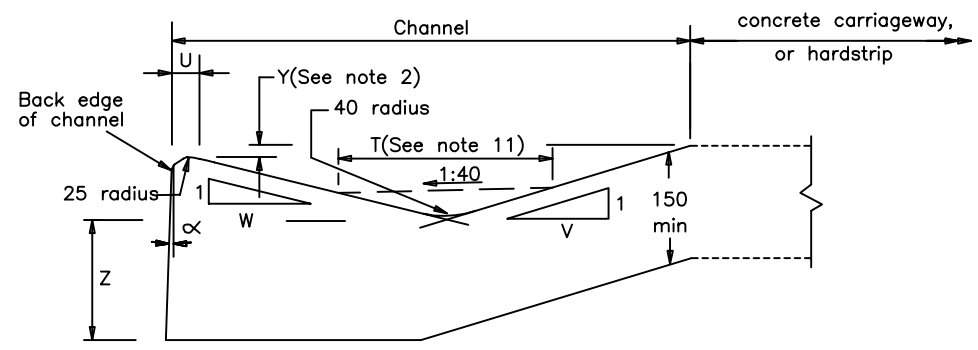

**Type B**  
 (Channel cast in one with the pavement)  
 (Drawn to suit central reserve location)

**NOTES**

1. ALL DIMENSIONS ARE IN MILLIMETRES.
2. Dimensions T,U,V,W,X,Y & Z shall be as described in Appendix 5/3. The dimension Y is the difference in level between the back edge of the channel and the level of the carriage way, hardshoulder or hardstrip adjacent to the channel. Dimension Y is +ve when the carriage way edge of the channel is above the verge edge. Dimension Y is -ve when the channel is below the verge edge.
3. The edges of the channel should be approximately vertical but Angle  $\alpha$  may lie between  $0^\circ$  and  $5^\circ$  for ease of slipforming.
4. Channel Type B shall be used when the carriage way and channel are slipformed simultaneously. Type B Channels shall be deemed a continuation of the carriage way slab and shall be reinforced accordingly. Concrete to Type B channels shall be as specified for the carriage way slab. Type B channels shall have transverse joints of the same type and spacing as in the carriage way slab, sealed in accordance with Clauses 1016 and 1017 of S.H.W.
5. Concrete to Type A channel shall comply with clause 1103 and shall be a designed mix, Grade C35 to BS 5328. air-entrained in accordance with BS 5931.
6. Contraction joints in Type A channels shall be sawn or wet formed. Sawn joints shall be cut to a minimum depth of 25mm below the channel invert or to a minimum depth of one quarter of the channel section whichever is the greater. Wet formed joints shall be cut into the concrete whilst it is still plastic with a sharp steel trowel to separate coarse aggregate particles over not less than two thirds of the cross-sectional area and finished using a keeled trowel or equivalent tool, to form a tapered sealing groove, not less than 13mm in width at the surface, tapering to not less than 5mm at a depth of 25mm.
7. The spacing of contraction joints in Type A channels shall be 5000mm. When required by Clause 1103, expansion joints shall be formed at spacings not exceeding 40000mm in accordance with Clause 1009. Joints shall be sealed in accordance with Clause 1016 and 1017 of S.H.W.
8. Sealing strip is required when Type A channels are used with rigid carriage way construction and shall be in accordance with Clause 1014 of S.H.W.
9. For channels in the verge, limited flooding of the hardshoulder or hardstrip may be permitted in exceptional rainfall conditions. For central reserve channels flooding must not encroach on to the carriage way or hardstrip.
10. The 40mm flat shown on the edge of the Type A channel is intended to minimise damage when the adjacent pavement layers are being compacted.
10. Type A and Type B channels indicate profiles of triangular surface water channels in solid lines. Broken lines of width T at crossfall 1:40 denote base profile of trapezoidal surface water channel.

|       |        |
|-------|--------|
| C     | MAR 98 |
| B     | AUG 93 |
| A     | DEC 91 |
| Issue | Date   |

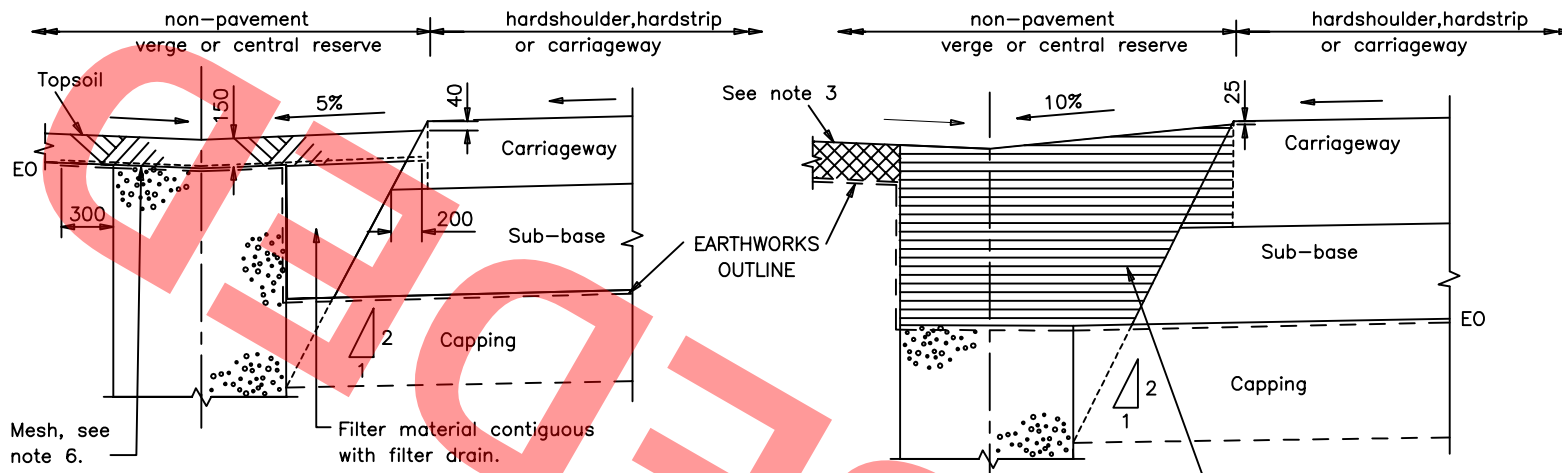

TYPE V

TYPE W

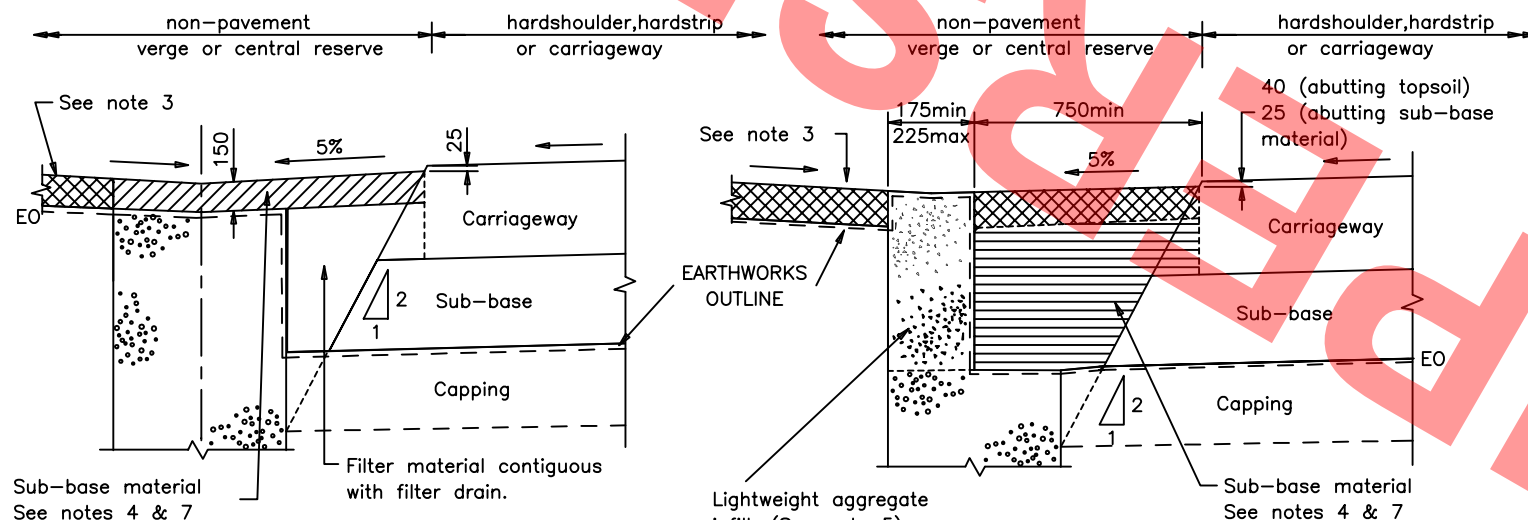

TYPE X

TYPE Y

NOTES

1. ALL DIMENSIONS ARE IN MILLIMETRES.
2. The Drawing shows alternative treatments to top of drains shown on drawings B1 & B5 and is applicable to rigid and flexible carriageway options. Filter, sub-base and topsoil materials should be taken to the edge of pavement layer as appropriate.
3. Material in this layer may be topsoil or sub-base material and the depth and type shall be as described in Appendix 5/1
4. Sub-base material shall be unbound material as specified in Clause 801 of S.H.W.
5. Material in this infill shall be lightweight aggregate as described in Appendix 5/1.
6. The geotextile shall be as described in Appendix 5/1 and shall be fixed in a convenient pavement layer to give required topsoil thickness  $\pm 50\text{mm}$ .
7. Where described in Appendix 5/1 a geotextile membrane shall be provided between the type B filter material and overlying layers for drain types W, X & Y.
8. For dimensions of filter drain relative to pavement layer see Drawings B1 & B5.
9. Detail of lower section of filter drain shall be as types G, H or I in Drawing F2 or as described in Appendix 5/1.

HIGHWAY CONSTRUCTION DETAILS

EDGE OF PAVEMENT  
DETAILS

|       |        |
|-------|--------|
| B     | MAR 98 |
| A     | DEC 91 |
| Issue | Date   |

CUTTINGS AND CENTRAL RESERVE  
COMBINED SURFACE AND  
GROUND WATER FILTER DRAINS

Drawing No.

B15

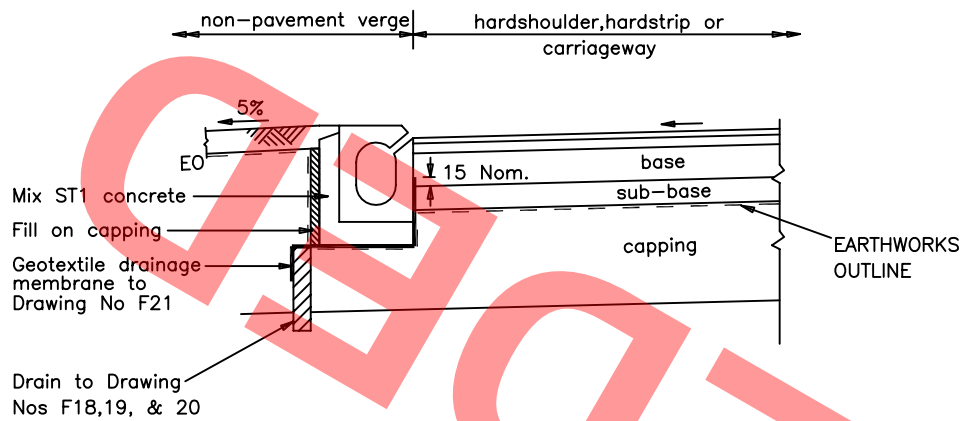

TYPE 25A  
(Flexible carriageway)

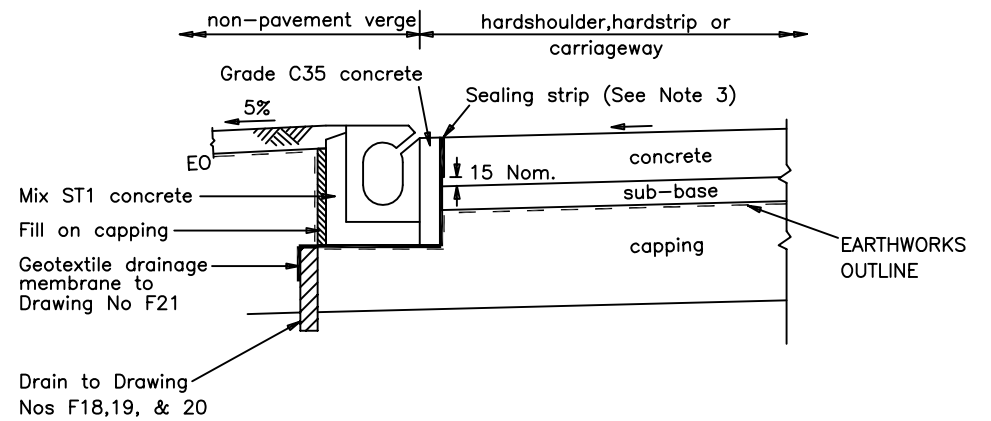

TYPE 25B  
(Rigid carriageway)

NOTES

- ALL DIMENSIONS ARE IN MILLIMETRES.  
These details also apply to flexible composite and rigid composite carriageway with necessary modification.  
Rigid composite as Type 25B but with bituminous surfacing laid up to front face of block as Type 25A, and without the sealing strip.  
Flexible composite as Type 25A down to top surface of base, lower details as Type 25B.
- The sealing strip and vertical part of geotextile drainage membrane are shown for when block is constructed before pavement. They shall be fixed to pavement edge when pavement cast before block.
- Sealing strip to be to Clause 1014 of S.H.W.
- Where used in conjunction with a thin surfacing the under drainage shown in F21 shall apply in full.

HIGHWAY CONSTRUCTION DETAILS

EDGE OF PAVEMENT  
DETAILS

|       |        |
|-------|--------|
| B     | MAY 02 |
| A     | MAR 98 |
| Issue | Date   |

EMBANKMENTS – COMBINED  
DRAINAGE AND KERB BLOCKS

Drawing No.

B16

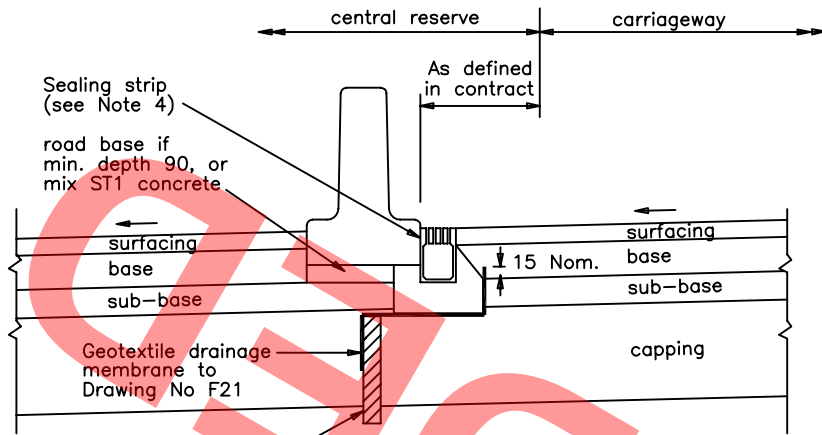

Drain to Drawing  
Nos F18,19, & 20

TYPE A1  
(Flexible carriageway)

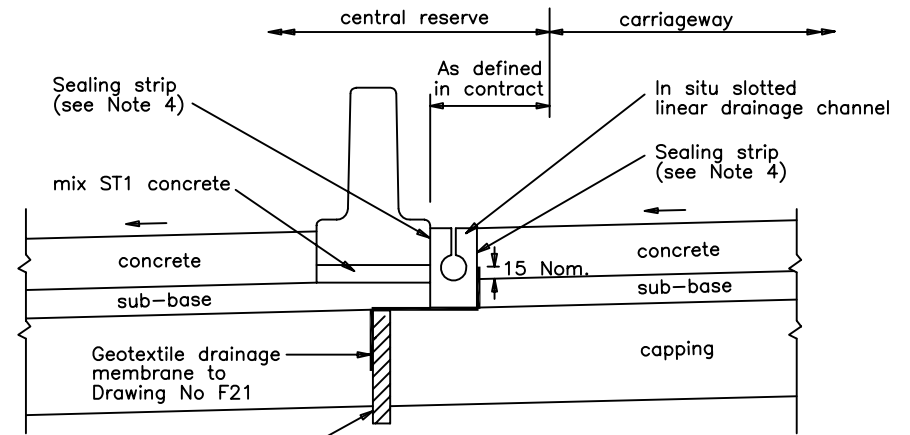

Drain to Drawing  
Nos F18,19, & 20

TYPE B1  
(In situ system with rigid carriageway)

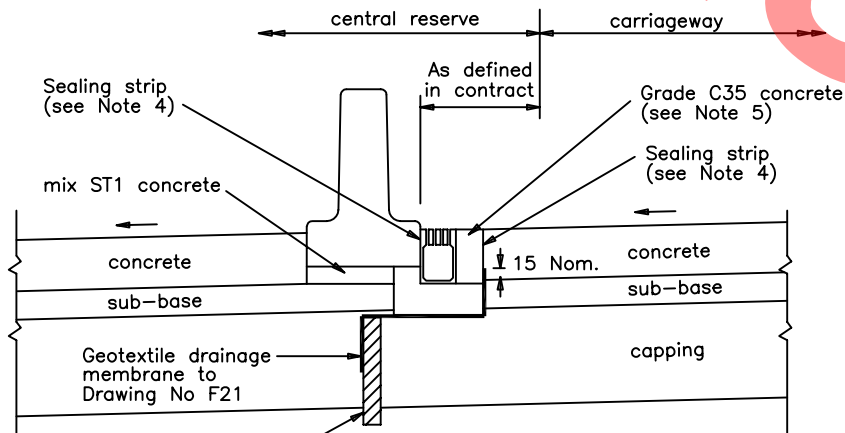

Drain to Drawing  
Nos F18,19, & 20

TYPE A2  
(Proprietary precast system  
with rigid carriageway)

#### NOTES

- ALL DIMENSIONS ARE IN MILLIMETRES.
- Type A (proprietary precast) and Type B (in situ) systems are applicable to flexible, flexible composite, rigid or rigid composite carriageway with any necessary modifications.
- The sealing strips and the vertical part of the geotextile drainage membrane are shown for when the linear drainage system is constructed before the pavement and/or V.C.B. They shall be fixed to the pavement and/or V.C.B. edge when the pavement and/or V.C.B. is cast before the linear drainage system.
- The geotextile drainage layer and drain to Drawing Nos. F18, 19 & 20 may be omitted if there is no drainage discontinuity in the pavement and capping layers.
- pavement edge when pavement cast before block.
- Sealing strip to be to Clause 1014 of S.H.W.
- Concrete between the proprietary system and the URC, JRC, CRCP or CRCR concrete slab shall be Grade C35 to a depth of not less than the thickness of the slab.
- Proprietary precast system and associated bed and backing concrete must be constructed in accordance with manufacturers' recommendations and be isolated from adjacent in situ concrete construction by suitable sealed expansion joints.
- Sealing strips required between in situ system and adjacent V.C.B., and between in situ system and adjacent rigid or rigid composite carriageway.
- Notwithstanding other tolerances in the Specification, the finished level of the linear drainage system shall not be higher nor more than 10mm lower than the finished level of the edge of the adjacent carriageway or hardstrip.
- Notwithstanding the slot dimensions given in SHW Clause 517.5, on motorways where single slotted linear drainage channels are used with a Vertical Concrete Barrier (V.C.B.), straight slots between 10mm and 32mm may not be restricted to limitations in length.
- Where used in conjunction with a thin surfacing the under drainage shown in F21 shall apply in full.

HIGHWAY CONSTRUCTION DETAILS

EDGE OF PAVEMENT  
DETAILS

|       |        |
|-------|--------|
| B     | MAY 02 |
| A     | MAR 98 |
| Issue | Date   |

CENTRAL RESERVE  
LINEAR DRAINAGE SYSTEM  
WITH V.C.B.

Drawing No.

B17

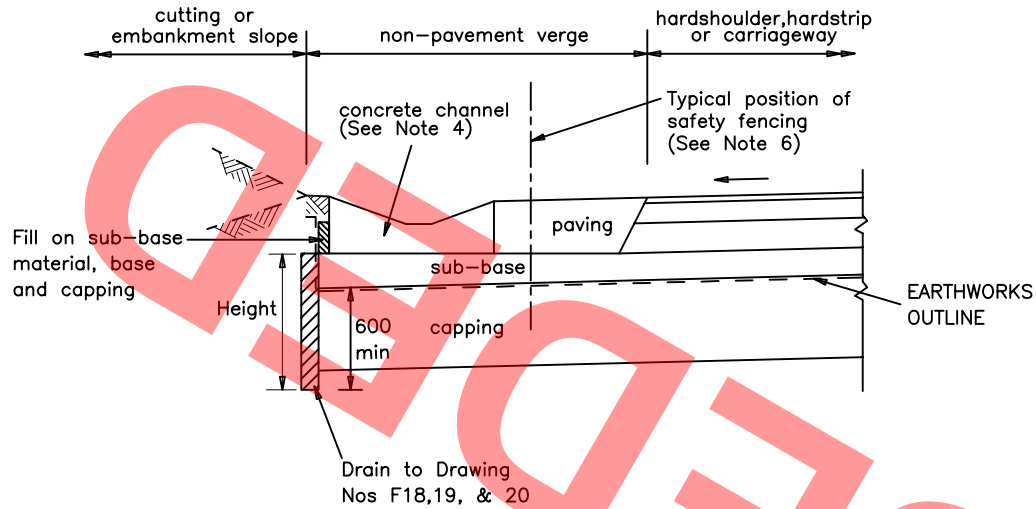

NOTES

1. ALL DIMENSIONS ARE IN MILLIMETRES.
2. These details also apply to rigid carriageway with addition of separation membrane and under channel drainage layer. Also applies to flexible composite carriageway with any necessary modifications.
3. Paving between the surface water channel and the hardshoulder, hardstrip or carriageway shall be as described in Appendix 5/3 or shown on the drawings.
4. Dimensions of concrete channel shall be as described in Appendix 5/3. General criteria for channel requiring safety fencing protection is that channel depth exceeds 150mm or that cross-falls exceed 1:4. Where used in conjunction with a thin surfacing the under drainage detail shown in F21 shall apply in full.
5. Notwithstanding other tolerances in the specification, the finished level of the channel shall not be higher than the finished level of the adjacent paving. Similarly the finished level of the paving shall not be higher than the finished level of the adjacent hardshoulder, hardstrip or carriageway.
6. Safety fencing to be as shown on the Drawings and scheduled in Appendices 4/1 and 4/2.
7. Detail shows channel in verge location. For channels in central reserve location, the post and concrete post foundations must not be coincident with drain to drawings F18, 19 and 20.

HIGHWAY CONSTRUCTION DETAILS

EDGE OF PAVEMENT  
DETAILS

|       |        |
|-------|--------|
|       |        |
| B     | MAY 02 |
| A     | MAR 98 |
| Issue | Date   |

SURFACE WATER CHANNEL  
REQUIRING SAFETY FENCING  
PROTECTION

Drawing No.

B18